

**MOTORIDUTTORI E RIDUTTORI
A VITE SENZA FINE CHM**

**CHM WORM GEARED MOTORS
AND WORM GEAR UNITS**



PREMESSA - INTRODUCTION

I riduttori a vite senza fine della Chiaravalli SpA hanno forma quadrata e si caratterizzano per la notevole versatilità di montaggio. La lavorazione dei componenti, eseguita con macchine a controllo numerico, garantisce la massima precisione delle ristrette tolleranze permettendo quindi di ottenere un prodotto affidabile nel tempo. I gruppi sono costruiti con casse in alluminio dalla grandezza 025 alla 090 mentre le grandezze 110 e 130 sono in ghisa.

Tutte le casse vengono verniciate color alluminio RAL 9022 per proteggere le parti dall'invecchiamento e per ottenere una migliore protezione dalle microsoffiature che possono essere presenti nell'alluminio.

I riduttori vengono forniti di almeno un tappo di carico che viene utilizzato anche in fase di collaudo per verificare possibili perdite. Una flangia di collegamento permette la combinazione di due riduttori per ottenere alti rapporti di riduzione.

Sono disponibili quattro grandezze di precoppie CHPC ad ingranaggi da abbinare ai riduttori, anche queste sono costruite in alluminio e sottoposte a trattamento di verniciatura come i riduttori a vite.

Tutti i gruppi vengono forniti completi di lubrificante le cui caratteristiche sono descritte nella tabella sottostante.

LUBRIFICAZIONE

	CHM 025/090	CHM 110/130			CHPC
Lubrificante	Sintetico	Minerale	Minerale	Minerale	Sintetico
°C ambiente	-25°C/+50°C	-25°C/+50°C	-5°C/+40°C	-15°C/+25°C	-25°C/+50°C
ISO	VG320	VG320	VG460	VG220	VG320
AGIP	TELIUM VSF 320	BLASIA 320	BLASIA 460	BLASIA 220	TELIUM VSF 320
SHELL	TIVELA OIL S 320	OMALA OIL 320	OMALA OIL 460	OMALA OIL 220	TIVELA OIL SC 320
IP	TELIUM VSF	MELLANA OIL 320	MELLANA OIL 460	MELLANA OIL 220	TELIUM VSF

The worm gears made by Chiaravalli SpA are square and are considerably versatile for mounting. The machining of the components, carried out using numeric control machines, guarantees maximum precision for the restricted tolerances, producing a product that will remain reliable over time. The groups are constructed with aluminium casings from sizes 025 to 090, while the sizes 110 and 130 are made from cast iron.

All of the bodies are painted with RAL 9022 aluminium colour to protect the parts from aging and to give better protection against micro-blowholes that may be present in the aluminium.

The gears are supplied with at least one filling plug that is also used during testing to check for possible leaks.

A connection flange allows two gears to be combined in order to obtain high gear ratios.

Four sizes of CHPC pre-stage gears are available to pair with the gears; these are also constructed in aluminium and are painted like the worm gears.

All of the groups are supplied with a lubricant whose characteristics are described in the following table.

LUBRICATION

	CHM 025/090	CHM 110/130			CHPC
Lubricant	Synthetic	Mineral	Mineral	Mineral	Synthetic
°C ambient	-25°C/+50°C	-25°C/+50°C	-5°C/+40°C	-15°C/+25°C	-25°C/+50°C
ISO	VG320	VG320	VG460	VG220	VG320
AGIP	TELIUM VSF 320	BLASIA 320	BLASIA 460	BLASIA 220	TELIUM VSF 320
SHELL	TIVELA OIL S 320	OMALA OIL 320	OMALA OIL 460	OMALA OIL 220	TIVELA OIL SC 320
IP	TELIUM VSF	MELLANA OIL 320	MELLANA OIL 460	MELLANA OIL 220	TELIUM VSF

LUBRIFICAZIONE

I riduttori dalla grandezza 025 alla grandezza 090 vengono forniti completi di olio sintetico pertanto non richiedono alcuna manutenzione. I riduttori grandezza 110 e 130 vengono forniti completi di olio minerale nella quantità prevista in posizione di montaggio B3, sarà cura del cliente adattare la quantità di olio alla posizione di montaggio ed inoltre sostituire il tappo di carico, fornito chiuso per motivi di trasporto, con quello dotato di sfiato allegato al riduttore. La mancata installazione del tappo di sfiato può creare pressioni interne con conseguente perdita di olio dagli anelli di tenuta. Per le grandezze 110 e 130 dopo circa 300 ore lavorative, periodo di rodaggio, si consiglia la sostituzione dell'olio.

LUBRICATION

The size 025 to 090 gears are supplied complete with synthetic oil and therefore do not require any maintenance. The size 110 and 130 gears are supplied with the quantity of mineral oil foreseen for the B3 assembly position. It is the client's responsibility to adapt the quantity of oil to the assembly position and in addition, to substitute the filling plug, supplied closed for transport reasons, with the one equipped with a hole attached to the gear. If the breather plug is not installed it may create internal pressure with a consequent leakage of oil from the oil seals. For the sizes 110 and 130 we recommend that the oil is changed after the running in period, approx. 300 working hours.

QUANTITA' OLIO LITRI - QUANTITY OF OIL IN LITRES

CHM	025	030	040	050	063	075	090	110	130	CHPC	63	71	80	90
B3	0.02	0.04	0.08	0.15	0.30	0.55	1	3	4.5		0.05	0.07	0.15	0.16
B8	0.02	0.04	0.08	0.15	0.30	0.55	1	2.2	3.3		0.05	0.07	0.15	0.16
B6/B7	0.02	0.04	0.08	0.15	0.30	0.55	1	2.5	3.5		0.05	0.07	0.15	0.16
V5	0.02	0.04	0.08	0.15	0.30	0.55	1	3	4.5		0.05	0.07	0.15	0.16
V6	0.02	0.04	0.08	0.15	0.30	0.55	1	2.2	3.3		0.05	0.07	0.15	0.16

PREDISPOSIZIONE ATTACCO MOTORE

I riduttori che vengono forniti con predisposizione attacco motore devono essere accoppiati a motori che abbiano tolleranze di albero e flangia corrispondenti ad una qualità di classe normale onde evitare vibrazioni e forzature del cuscinetto in entrata, i motori forniti da Chiaravalli garantiscono la rispondenza a queste esigenze.

Nella tabella seguente viene messa in corrispondenza la grandezza del motore B5 e B14 con le dimensioni dell'albero e della flangia attacco motore onde agevolare la consultazione. Si ricorda che, essendo le flange attacco motore scindibili dalla cassa è sempre possibile la combinazione di alberi e flange non corrispondenti alla tabella es. 19/140, questa soluzione permette di adattarsi anche a motori non unificati es. brushless o corrette continua.

PAM	056	063	071	080	090	100	112	132
B5	9/120	11/140	14/160	19/200	24/200	28/250	28/250	38/300
B14	9/80	11/90	14/105	19/120	24/140	28/160	28/160	38/200

MOTOR MOUNTING FLANGES

Gears that are supplied with mounting flanges must be assembled with motors whose shaft and flange tolerances correspond to a "normal class" of quality in order to avoid vibration and forcing of the input bearing. Motors supplied by Chiaravalli guarantee that this requirement is fulfilled. For ease of consultation, the correspondence of the size of the B5 and B14 motor with the sizes of the shaft and the motor connection flange are shown in the following table.

Remember that, as the motor connection flanges are separate from the body it is also possible to have a shaft / flange combination that does not correspond to the table, e.g. 19/140, thereby offering adaptability for other non-unified models such as the brushless or direct current types.

MMF	056	063	071	080	090	100	112	132
B5	9/120	11/140	14/160	19/200	24/200	28/250	28/250	38/300
B14	9/80	11/90	14/105	19/120	24/140	28/160	28/160	38/200



TIPO (1)	GRANDEZZA (2)	VERSIONE (3)	POS. FLANGIA (4)	i	P.A.M.	POS.MONT (4)
TYPE (1)	SIZE (2)	VERSION (3)	FLANGE POS. (4)	i	M.M.F.	MOUNT. POS. (4)
CHM	025	FA	1	7.5	Vedi pag. 30 - See page 30	U UNIVERSALE
	030	FB	2	10		B3
CHMR	040	FC		15		B8
	050	FD		20		B6
CHME	063	FE		25		B7
	075			30		V5
CHMRE	090			40		V6
	110			50		
	130			60		
				80		
			100			

ESEMPIO ORDINE - ORDER EXAMPLE

CHM	090	FA (5)	2 (5)	30	90 B14	V5
-----	-----	--------	-------	----	--------	----

Nel caso venga richiesto anche il motore specificare:

If the motor is also required, please specify:

Grandezza - Size	es. 90 L4
Potenza - Power	es. Kw 1.5
Poli - Poles	es. 4
Tensione - Voltage	es. V230/400
Frequenza - Frequency	es. 50 Hz
Flangia - Flange	es. B 14

N.B. I riduttori dalla grandezza 25 alla grandezza 63 vengono sempre forniti in pos. Universale possono quindi essere montati in qualsiasi posizione, dalla grandezza 75 alla grandezza 130 è necessario specificare la pos. se diversa dalla B3.

In particolare nel caso in cui un riduttore in B3 vada montato nelle pos. V5 o V6, sarà necessario lubrificare il cuscinetto posto nel lato superiore con grasso apposito che ne garantisca la lubrificazione.

Il grasso da noi testato è il TecnoLubeseal POLYMER 400/2.

N.B. From size 25 to 63 the gears are always supplied in the Universal position and can therefore be mounted in any position, from size 75 to size 130 if the position required differs from B3 it must be specified.

In particular, in the event that a gear in position B3 is to be mounted in positions V5 or V6, the bearing positioned in the upper side must be lubricated using suitable grease that ensures proper lubrication.

We have tested TecnoLubeseal POLYMER 400/2 grease.

1) vedi pagina 26 - see page 26

2) vedi da pagina 31 a pag 40 - see from page 31 to page 40

3) vedi da pagina 31 a pag 40 - see from page 31 to page 40

4) vedi pagina 30 - see page 30

5) nessuna indicazione significa che il riduttore è privo di flangia in uscita.

lack of instructions indicates that the gear is not equipped with an output flange.

POSIZIONE DI MONTAGGIO - MOUNTING POSITION

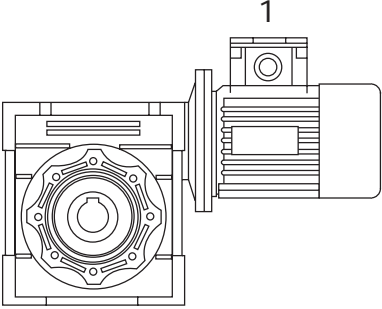
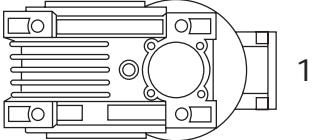
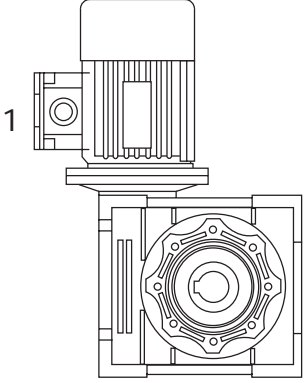
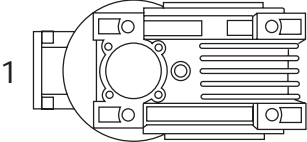
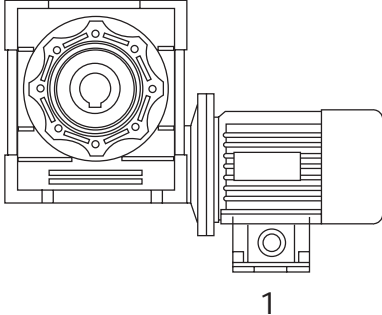
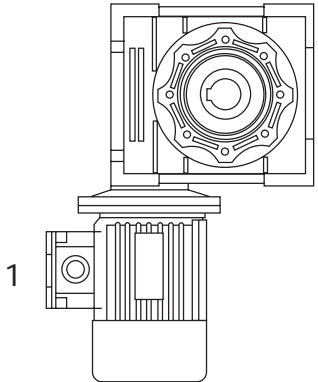
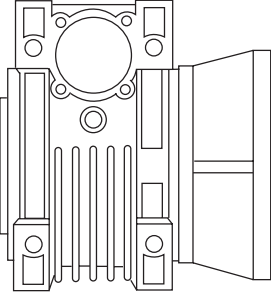
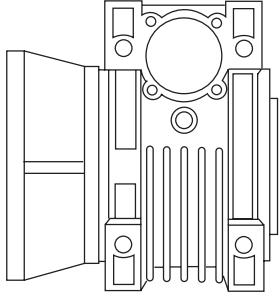
<p>B3</p> 	<p>B6</p> 	<p>V5</p> 	
<p>B7</p> 	<p>B8</p> 	<p>V6</p> 	
<p>F...1</p> 		<p>F...2</p> 	

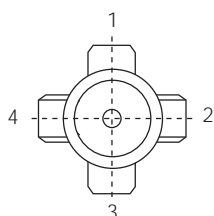

B3

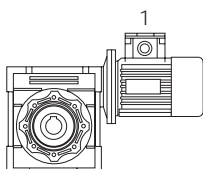

POSIZIONE MORSETTERIA

N.B. la posizione della morsetteria si riferisce sempre alla pos. B3

TERMINAL BOX POSITION

N.B. The position of the terminal box always refers to the B3 position.



CHM 025

PRESTAZIONI CON MOTORI A 4 POLI - 1400 GIRI ENTRATA PERFORMANCE WITH 4-POLE MOTORS - 1400 REVS. INPUT

TIPO	i=ratio	n2 r/min	Kw=P1	Nm=T2	f.s.	Pred. attacco motore possibili	
TYPE	i=ratio	n2 r/min	Kw=P1	Nm=T2	f.s.	Possible types of motor connections	
CHM 025	7.5	186.7	0.09	3.8	2.8	56	B14
	10	140.0	0.09	5	2.4	56	B14
	15	93.3	0.09	7.2	1.6	56	B14
	20	70.0	0.09	9	1.3	56	B14
	25	56.0	0.09	10	1.0	56	B14
	30	46.7	0.09	12.3	1.1	56	B14
	40	35.0	0.09	13	1.0	56	B14
	50	28.0	0.09	14	0.7	56	B14
	60	23.3	0.09	14	0.6	56	B14

DIMENSIONI - DIMENSIONS

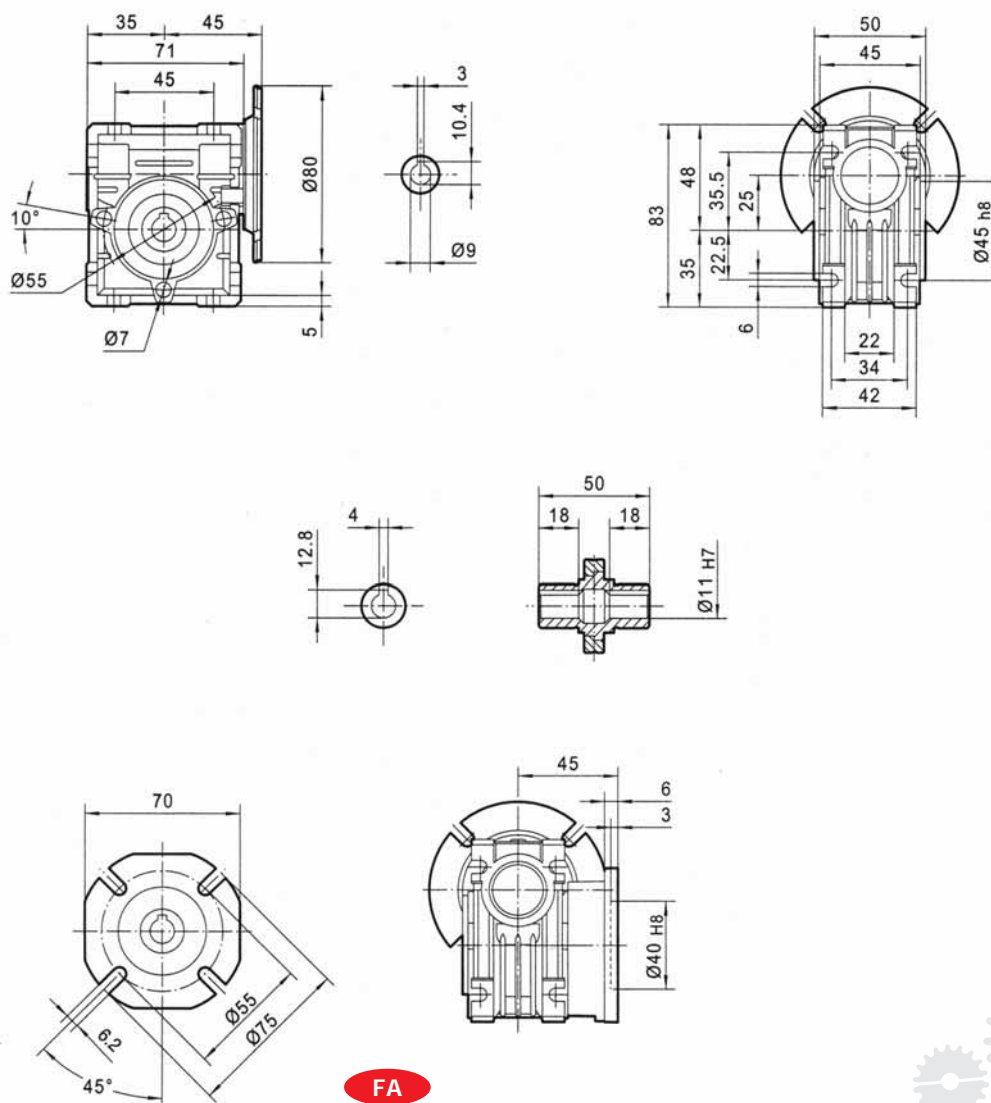

FA



Peso Kg 0.7 senza motore
Weight 0.7 Kg excluding motor

CHM 030

PRESTAZIONI CON MOTORI A 4 POLI - 1400 GIRI ENTRATA PERFORMANCE WITH 4-POLE MOTORS - 1400 REVS. INPUT

TIPO	i=ratio	n2 r/min	Kw=P1	Nm=T2	f.s.	Pred. attacco motore possibili	
TYPE	i=ratio	n2 r/min	Kw=P1	Nm=T2	f.s.	Possible types of motor connections	
	7.5	186.7	0.22	9	2.1	63/56	B5/B14
	10	140.0	0.22	11	1.6	63/56	B5/B14
	15	93.3	0.22	16	1.0	63/56	B5/B14
	20	70.0	0.22	20	0.9	63/56	B5/B14
CHM 030	25	56.0	0.18	20	1.0	63/56	B5/B14
	30	46.7	0.18	22	0.9	63/56	B5/B14
	40	35.0	0.18	21	0.8	63/56	B5/B14
	50	28.0	0.18	19	0.8	63/56	B5/B14
	60	23.3	0.09	18	0.9	56	B5/B14
	80	17.5	0.09	13	0.9	56	B5/B14

DIMENSIONI - DIMENSIONS

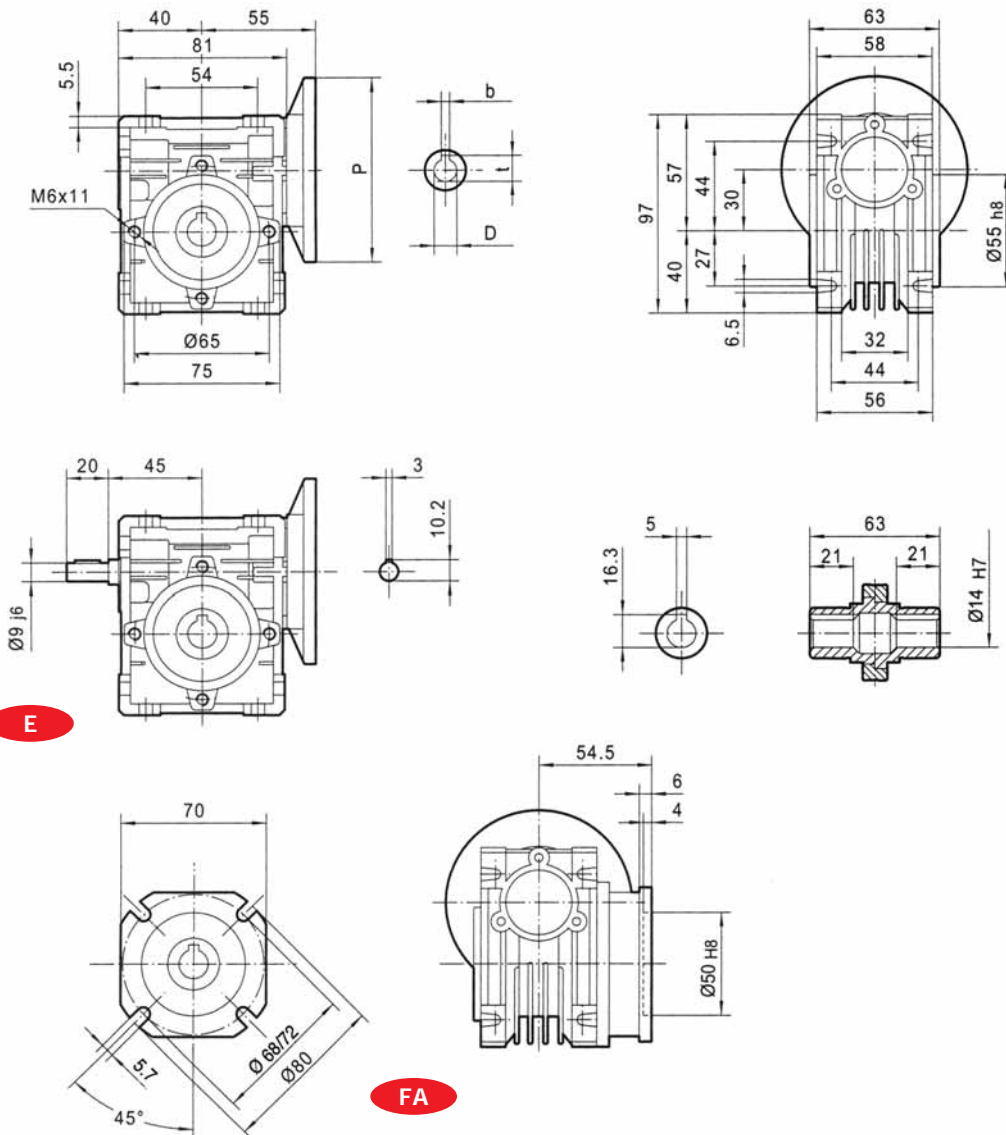

PAM IEC	P	DE8	b	t
---------	---	-----	---	---

63B5	140	11	4	12.8
56B5	120	9	3	10.4

PAM IEC	P	DE8	b	t
---------	---	-----	---	---

63B14	90	11	4	12.8
56B14	80	9	3	10.4

Peso Kg 1.2 senza motore
Weight 1.2 Kg excluding motor

CHM 040

PRESTAZIONI CON MOTORI A 4 POLI - 1400 GIRI ENTRATA PERFORMANCE WITH 4-POLE MOTORS - 1400 REVS. INPUT

TIPO	i=ratio	n2 r/min	Kw=P1	Nm=T2	f.s.	Pred. attacco motore possibili	
TYPE	i=ratio	n2 r/min	Kw=P1	Nm=T2	f.s.	Possible types of motor connections	
	7.5	186.7	0.55**	22	1.6	71/63	B5/B14
	10	140.0	0.55**	30	1.4	71/63	B5/B14
	15	93.3	0.55**	44	0.9	71/63	B5/B14
	20	70.0	0.55**	38	1.0	71/63	B5/B14
CHM 040	25	56.0	0.37	45	0.9	71/63	B5/B14
	30	46.7	0.37	52	0.8	71/63	B5/B14
	40	35.0	0.25	43	0.9	71/63	B5/B14
	50	28.0	0.22	44	0.9	63/56	B5/B14*
	60	23.3	0.18	42	0.8	63/56	B5/B14*
	80	17.5	0.18	36	0.8	63/56	B5/B14*
	100	14.0	0.18	35	0.8	63/56	B5/B14*

* 56 solo - only B5

** Motori grandezza 71 - Size 71 Motors

DIMENSIONI - DIMENSIONS

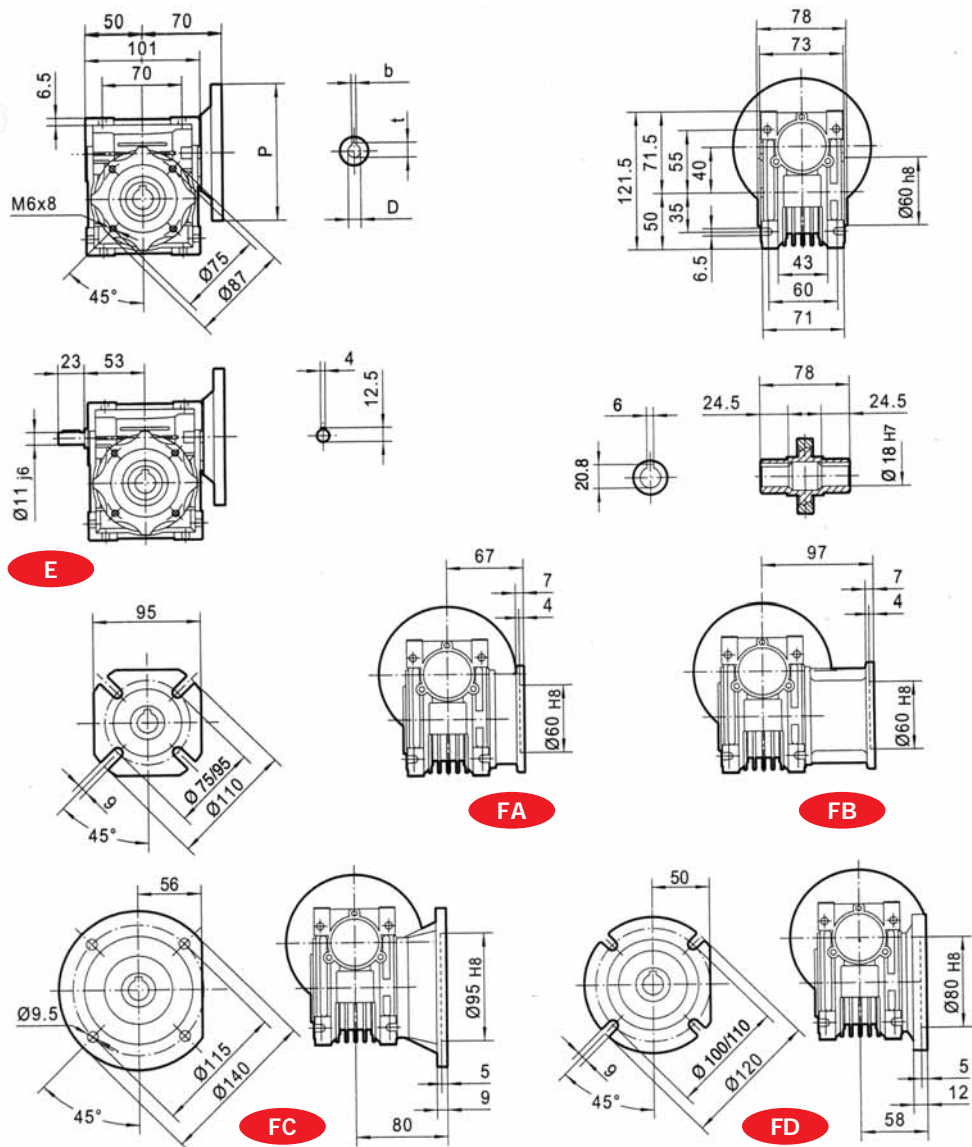

PAM IEC	P	DE8	b	t
71B5	160	14	5	16.3
63B5	140	11	4	12.8
56B5	120	9	3	10.4

PAM IEC	P	DE8	b	t
71B14	105	14	5	16.3
63B14	90	11	4	12.8

Peso Kg 2.3 senza motore
Weight 2.3 Kg excluding motor

CHM 050

PRESTAZIONI CON MOTORI A 4 POLI - 1400 GIRI ENTRATA PERFORMANCE WITH 4-POLE MOTORS - 1400 REVS. INPUT

TIPO	i=ratio	n2 r/min	Kw=P1	Nm=T2	f.s.	Pred. attacco motore possibili	
TYPE	i=ratio	n2 r/min	Kw=P1	Nm=T2	f.s.	Possible types of motor connections	
	7.5	186.7	0.75	33.3	2.0	80/71	B5/B14
	10	140.0	0.75	43.9	1.6	80/71	B5/B14
	15	93.3	0.75	62.6	1.2	80/71	B5/B14
	20	70.0	0.75	80	0.9	80/71	B5/B14
CHM 050	25	56.0	0.55	70	1.0	80/71	B5/B14
	30	46.7	0.55	80	1.0	80/71	B5/B14
	40	35.0	0.37	67	1.1	80/71/63	B5/B14*
	50	28.0	0.37	78	0.9	71/63	B5/B14*
	60	23.3	0.37	87	0.8	71/63	B5/B14*
	80	17.5	0.25	70	0.9	71/63	B5/B14*
	100	14.0	0.18	59	0.9	71/63	B5/B14*

* 63 solo - only B5

DIMENSIONI - DIMENSIONS

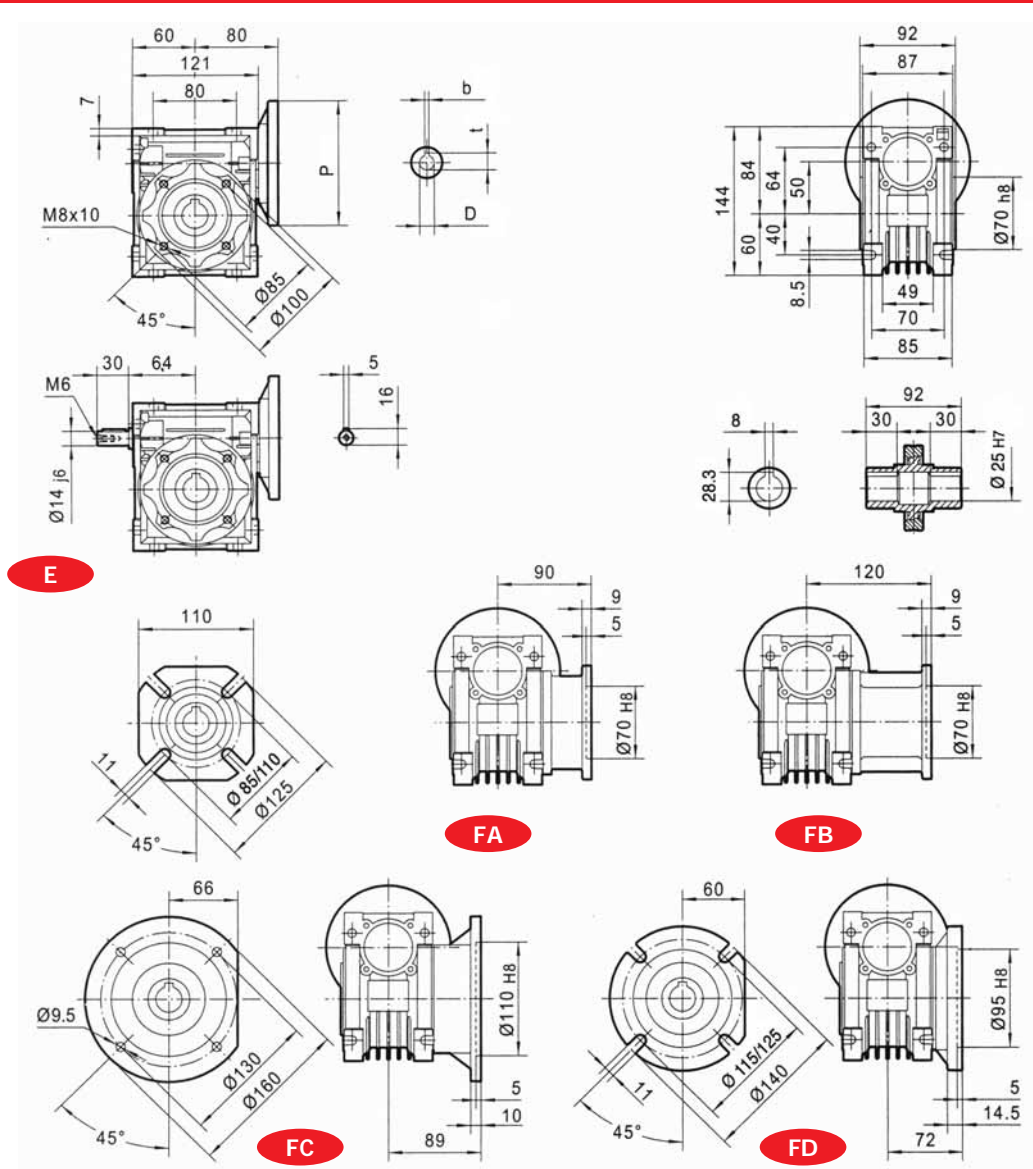

PAM IEC	P	DE8	b	t
80B5	200	19	6	21.8
71B5	160	14	5	16.3
63B5	140	11	4	12.8

PAM IEC	P	DE8	b	t
80B14	120	19	6	21.8
71B14	105	14	5	16.3

Peso Kg 3.5 senza motore

Weight 3.5 Kg excluding motor



CHM 063

PRESTAZIONI CON MOTORI A 4 POLI - 1400 GIRI ENTRATA PERFORMANCE WITH 4-POLE MOTORS - 1400 REVS. INPUT

TIPO	i=ratio	n2 r/min	Kw=P1	Nm=T2	f.s.	Pred. attacco motore possibili	
TYPE	i=ratio	n2 r/min	Kw=P1	Nm=T2	f.s.	Possible types of motor connections	
	7.5	186.7	1.50	67.4	1.8	90/80	B5/B14
	10	140.0	1.50	88.6	1.4	90/80	B5/B14
	15	93.3	1.50	126	1.19	90/80	B5/B14
	20	70.0	1.50	164	0.8	90/80	B5/B14
CHM 063	25	56.0	1.10	145	0.9	90/80	B5/B14
	30	46.7	1.10	165	1.0	90/80	B5/B14
	40	35.0	0.75	143	1.0	80/71	B5/B14
	50	28.0	0.55	122	1.1	80/71	B5/B14
	60	23.3	0.55	138	0.9	80/71	B5/B14
	80	17.5	0.37	114	1.1	80/71	B5/B14
	100	14.0	0.37	127	0.9	71	B5/B14

DIMENSIONI - DIMENSIONS

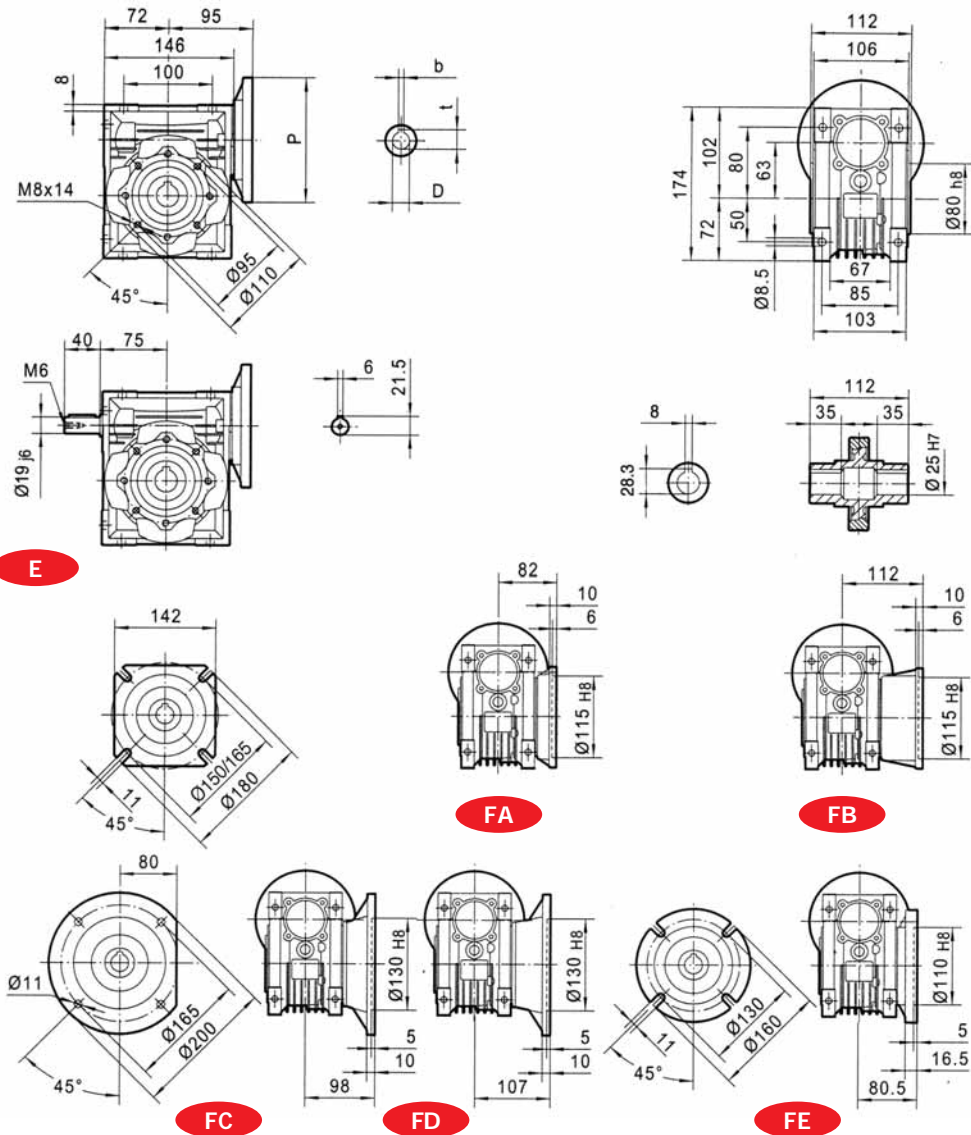

PAM IEC	P	DE8	b	t
90B5	200	24	8	27.3
80B5	200	19	6	21.8
71B5	160	14	5	16.3

PAM IEC	P	DE8	b	t
90B14	140	24	8	27.3
80B14	120	19	6	21.8
71B14	105	14	5	16.3

Peso Kg 6.2 senza motore
Weight 6.2 Kg excluding motor

CHM 75

PRESTAZIONI CON MOTORI A 4 POLI - 1400 GIRI ENTRATA PERFORMANCE WITH 4-POLE MOTORS - 1400 REVS. INPUT

TIPO	i=ratio	n2 r/min	Kw=P1	Nm=T2	f.s.	Pred. attacco motore possibili	
TYPE	i=ratio	n2 r/min	Kw=P1	Nm=T2	f.s.	Possible types of motor connections	
	7.5	186.7	4.00	180	1.0	100/90	B5/B14
	10	140.0	4.00	237	0.8	100/90	B5/B14
	15	93.3	3.00	260	0.8	100/90	B5/B14
	20	70.0	1.50	167	1.2	90/80	B5/B14
CHM 075	25	56.0	1.50	204	1.0	90/80	B5/B14
	30	46.7	1.50	232	1.0	90/80	B5/B14
	40	35.0	1.10	214	1.0	90/80	B5/B14
	50	28.0	0.75	176	1.2	90/80/71	B5/B14*
	60	23.3	0.75	199	1.0	80/71	B5/B14*
	80	17.5	0.55	178	1.1	80/71	B5/B14*
	100	14.0	0.55	203	0.9	80/71	B5/B14*

* 71 solo - only B5

DIMENSIONI - DIMENSIONS

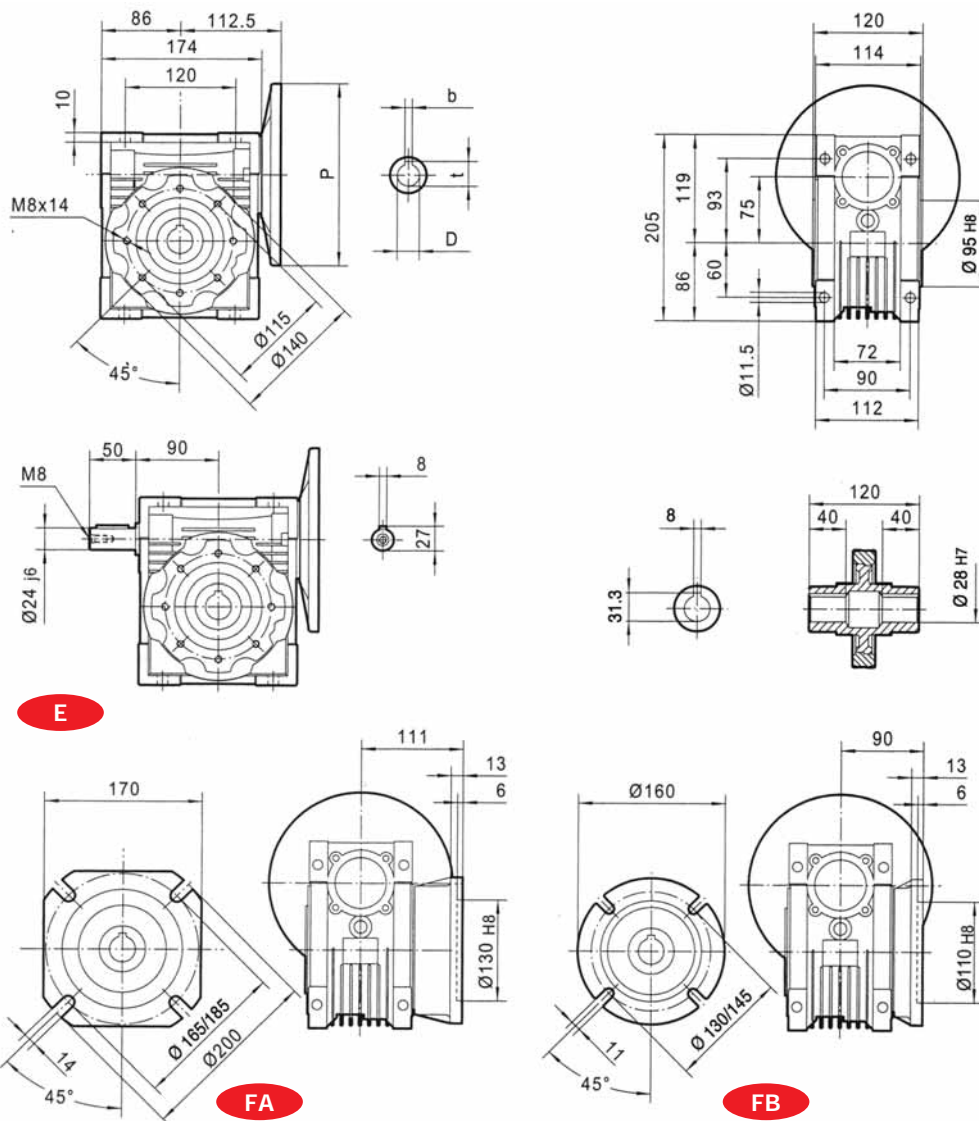

PAM IEC	P	DE8	b	t
100/112B5	250	28	8	31.3
90B5	200	24	8	27.3
80B5	200	19	6	21.8
71B5	160	14	5	16.3

PAM IEC	P	DE8	b	t
100/112B14	160	28	8	31.3
90B14	140	24	8	27.3
80B14	120	19	6	21.8

Peso Kg 9 senza motore
Weight 9 Kg excluding motor

CHM 090

PRESTAZIONI CON MOTORI A 4 POLI - 1400 GIRI ENTRATA PERFORMANCE WITH 4-POLE MOTORS - 1400 REVS. INPUT

TIPO	i=ratio	n2 r/min	Kw=P1	Nm=T2	f.s.	Pred. attacco motore possibili	
TYPE	i=ratio	n2 r/min	Kw=P1	Nm=T2	f.s.	Possible types of motor connections	
	7.5	186.7	4.00	184	1.5	100/90	B5/B14
	10	140.0	4.00	242	1.3	100/90	B5/B14
	15	93.3	4.00	351	1.1	100/90	B5/B14
	20	70.0	4.00	456	0.8	100/90	B5/B14
CHM 090	25	56.0	3.00	417	0.8	100/90	B5/B14
	30	46.7	3.00	478	0.9	100/90	B5/B14
	40	35.0	1.50	306	1.2	90/80	B5/B14
	50	28.0	1.50	367	1.0	90/80	B5/B14
	60	23.3	1.50	421	0.8	90/80	B5/B14
	80	17.5	0.75	257	1.1	80	B5/B14
	100	14.0	0.75	300	0.9	80	B5/B14

DIMENSIONI - DIMENSIONS

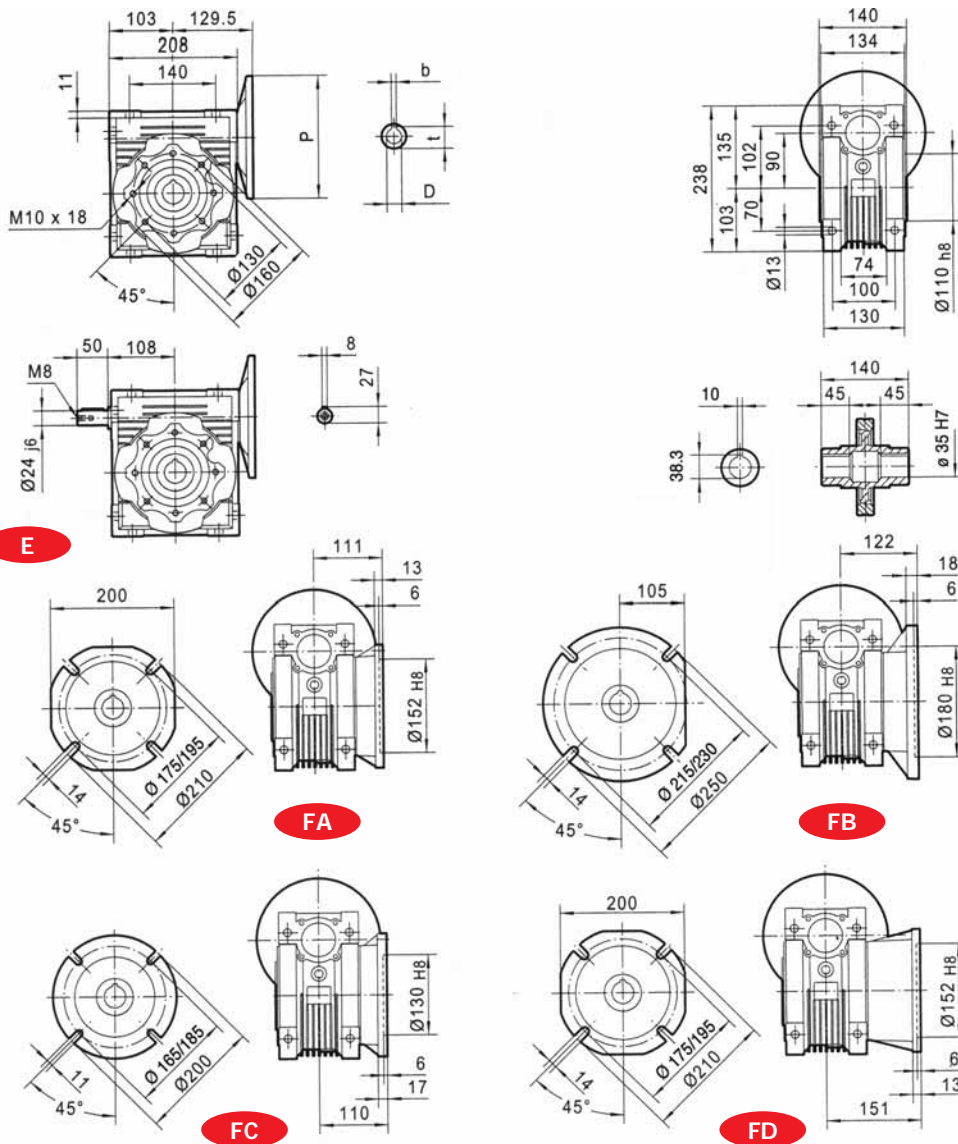

PAM IEC	P	DE8	b	t
100/112B5	250	28	8	31.3
90B5	200	24	8	27.3
80B5	200	19	6	21.8

PAM IEC	P	DE8	b	t
100/112B14	160	28	8	31.3
90B14	140	24	8	27.3
80B14	120	19	6	21.8

Peso Kg 13 senza motore
Weight 13 Kg excluding motor

CHM 110

PRESTAZIONI CON MOTORI A 4 POLI - 1400 GIRI ENTRATA PERFORMANCE WITH 4-POLE MOTORS - 1400 REVS. INPUT

TIPO	i=ratio	n2 r/min	Kw=P1	Nm=T2	f.s.	Pred. attacco motore possibili	
TYPE	i=ratio	n2 r/min	Kw=P1	Nm=T2	f.s.	Possible types of motor connections	
	7.5	186.7	7.50	344	1.6	132/112/100	B5/B14
	10	140.0	7.50	453	1.3	132/112/100	B5/B14
	15	93.3	7.50	659	1.0	132/112/100	B5/B14
	20	70.0	5.50	635	1.0	132/112/100	B5/B14
CHM 110	25	56.0	4.00	573	1.2	112/100	B5/B14
	30	46.7	4.00	645	1.1	112/100	B5/B14
	40	35.0	3.00	636	1.1	112/100/90	B5/B14*
	50	28.0	3.00	764	0.9	112/100/90	B5/B14*
	60	23.3	2.20	645	1.0	112/100/90	B5/B14*
	80	17.5	1.50	546	0.9	90	B5/B14*
	100	14.0	1.10	470	1.0	90	B5/B14*

* 90 solo - only B5

DIMENSIONI - DIMENSIONS

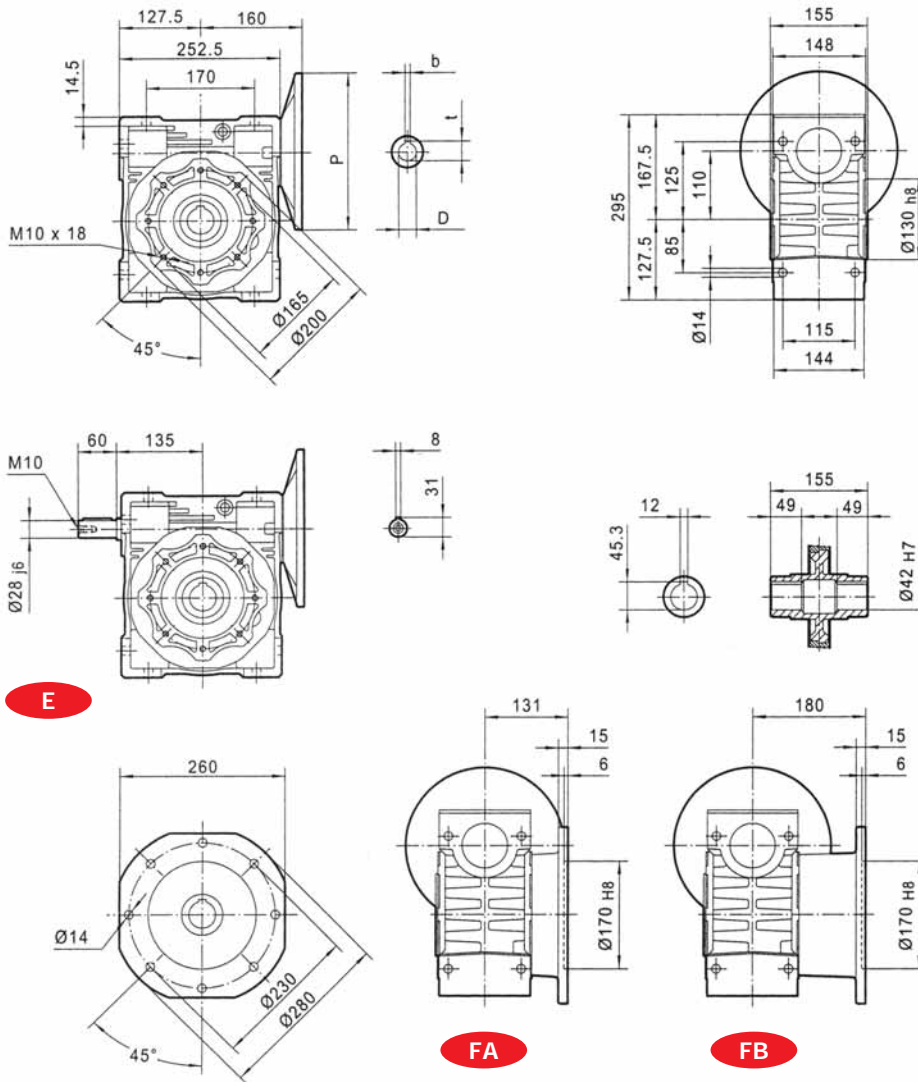

PAM IEC	P	DE8	b	t
132B5	300	38	10	41.3
112B5	250	28	8	31.3
100B5	250	28	8	31.3
90B5	200	24	8	27.3
80B5	200	19	6	21.8

PAM IEC	P	DE8	b	t
132B14	200	38	10	41.3
112B14	160	28	8	31.3
100B14	160	28	8	31.3

Peso Kg 35 senza motore

Weight 35 Kg excluding motor

CHM 130

PRESTAZIONI CON MOTORI A 4 POLI - 1400 GIRI ENTRATA PERFORMANCE WITH 4-POLE MOTORS - 1400 REVS. INPUT

TIPO	i=ratio	n2 r/min	Kw=P1	Nm=T2	f.s.	Pred. attacco motore possibili	
TYPE	i=ratio	n2 r/min	Kw=P1	Nm=T2	f.s.	Possible types of motor connections	
	7.5	186.7	7.50	348	2.2	132	B5/B14
	10	140.0	7.50	455	1.8	132	B5/B14
	15	93.3	7.50	660	1.2	132	B5/B14
	20	70.0	7.50	877	1.0	132	B5/B14
CHM 130	25	56.0	7.50	1071	0.9	132	B5/B14
	30	46.7	7.50	1225	0.8	132/112/100	B5/B14
	40	35.0	5.50	1173	0.9	132/112/100	B5/B14
	50	28.0	4.00	1023	0.9	100	B5/B14
	60	23.3	3.00	886	1.1	100	B5/B14
	80	17.5	3.00	1112	0.8	100/90	B5/B14*
	100	14.0	1.50	652	1.1	100/90	B5/B14*

* 90 solo - only B5

DIMENSIONI - DIMENSIONS

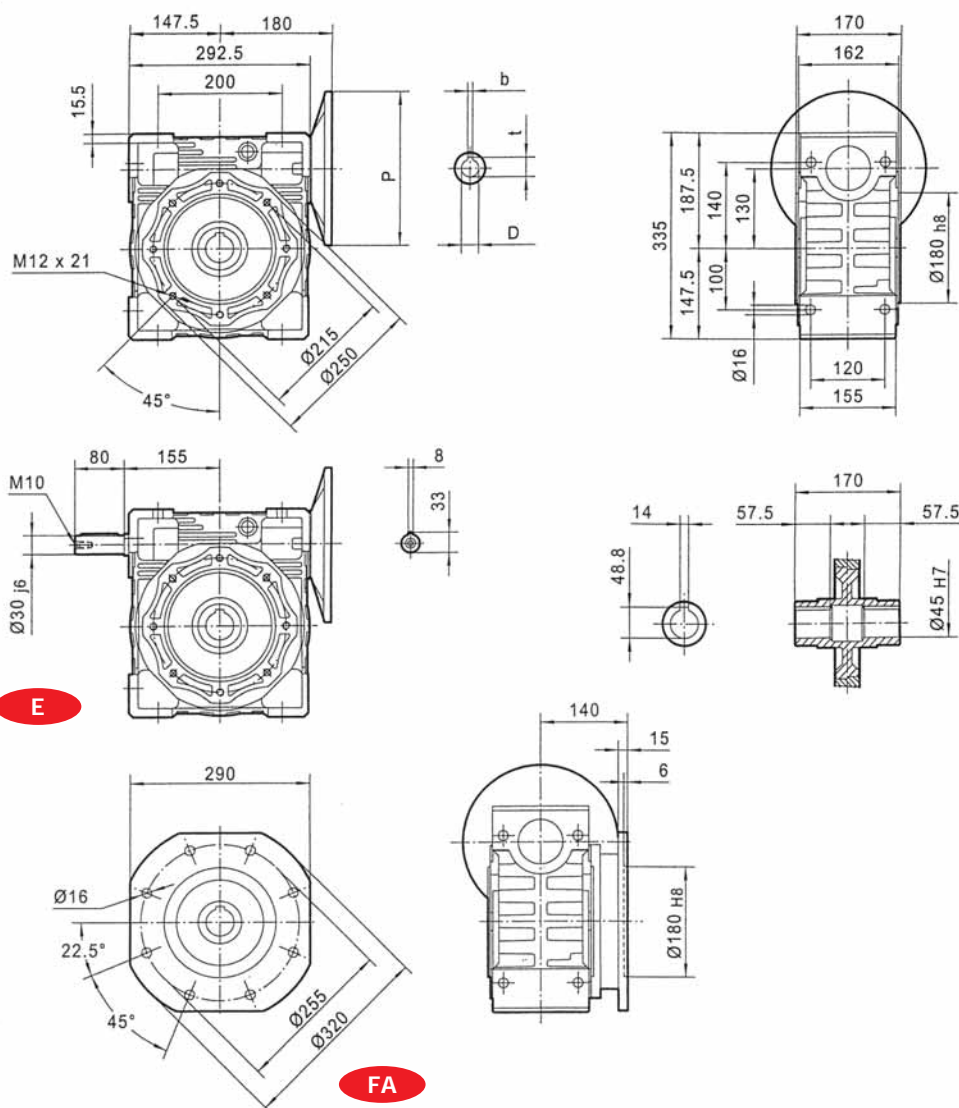

PAM IEC	P	DE8	b	t	PAM IEC	P	DE8	b	t
132B5	300	38	10	41.3	132B14	200	38	10	41.3
112B5	250	28	8	31.3	112B14	160	28	8	31.3
100B5	250	28	8	31.3	100B14	160	28	8	31.3
90B5	200	24	8	27.3					

Peso Kg 48 senza motore
Weight 48 Kg excluding motor

CHM 150

PRESTAZIONI CON MOTORI A 4 POLI - 1400 GIRI ENTRATA PERFORMANCE WITH 4-POLE MOTORS - 1400 REVS. INPUT

TIPO	i=ratio	n2 r/min	Kw=P1	Nm=T2	f.s.	Pred. attacco motore possibili	
TYPE	i=ratio	n2 r/min	Kw=P1	Nm=T2	f.s.	Possible types of motor connections	
	7.5	186.7	15	680	1.6	160	B5
	10	140.0	15	905	1.2	160	B5
	15	93.3	15	1310	0.9	160	B5
	20	70.0	11	1270	1.0	160	B5
CHM 150	25	56.0	11	1520	0.8	160	B5
	30	46.7	7.50	1240	0.8	132	B5
	40	35.0	7.50	1560	0.9	132	B5
	50	28.0	5.50	1405	0.9	132	B5
	60	23.3	5.50	1610	0.8	132	B5
	80	17.5	4	1430	0.8	112/100	B5
	100	14.0	3	1300	0.8	112/100	B5

DIMENSIONI - DIMENSIONS

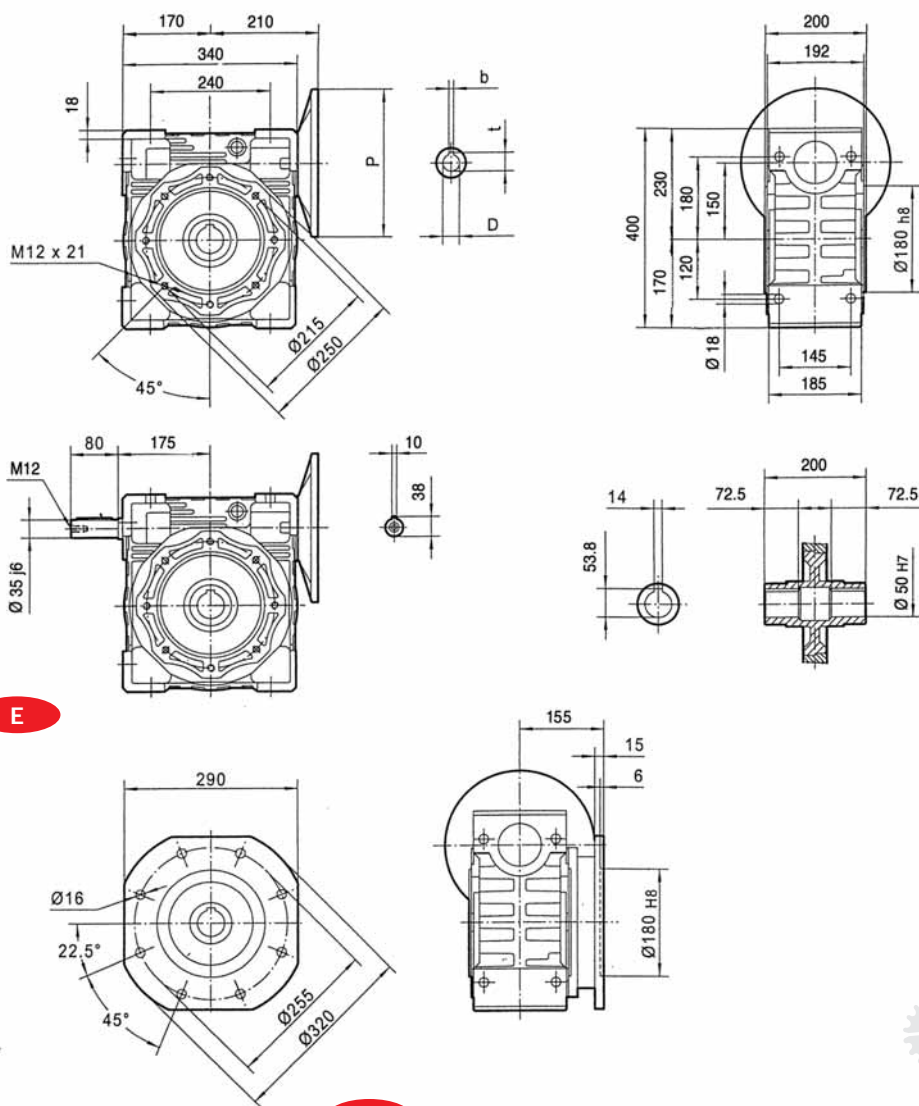

PAM IEC	P	DE8	b	t
160B5	350	42	12	45.3
132B5	300	38	10	41.3
112B5	250	28	8	31.3
100B5	250	28	8	31.3

Peso Kg 84 senza motore
Weight 84 Kg excluding motor

CHMR	030	040	050	063	075	090	110	130	150
A	20	23	30	40	50	50	60	80	80
D1 j6	9	11	14	19	24	24	28	30	35
B2	51	60	74	90	105	125	142	162	195
B3	45	53	64	75	90	108	135	155	175
a	30	40	50	63	75	90	110	130	150
b1	3	4	5	6	8	8	8	8	10
f1	-	-	M6	M6	M8	M8	M10	M10	M12
t1	10.2	12.5	16	21.5	27	27	31	33	38

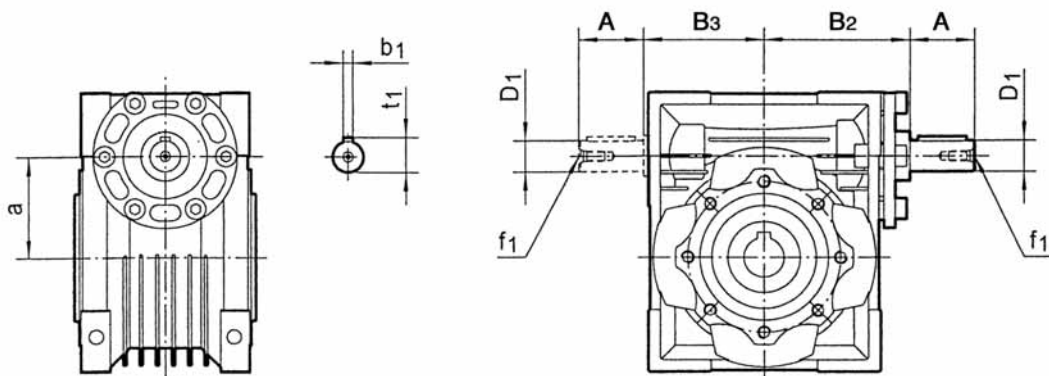

Per le dimensioni mancanti riferirsi al corrispondente CHM
 For the missing dimensions, please refer to the CHM correspondent





DESIGNAZIONE CHPC/CHM - CHME DESIGNATION CHPC/CHM - CHME

TIPO TYPE	GRANDEZZA SIZE	i =	P.A.M. M.M.F.	POS.MONT MOUNT. POS
CHPC	63	3	63B5	Nel caso venga fornita accoppiata al CHM o al CHME specificare la pos. di questi ultimi, quando la precoppia viene fornita da sola è prevista per montaggio universale.
	71	3	71B5	
	80	3	80B5	
	90	2.45	90B5	

If supplied coupled with CHM or CHME types specify the position of these, when the pre-stage module is supplied by itself it is prepared for universal assembly.

ESEMPIO ORDINE CHPC ACCOPPIATA A RIDUTTORE CHM O CHME

ORDER EXAMPLE FOR A CHPC COUPLED TO A CHM OR CHME GEAR

CHPC	90	CHM	110	i=245 (2.45x100)	P.A.M. M.M.F. 90B5	POS.B3
------	----	-----	-----	------------------	--------------------	--------

Nel caso venga richiesto anche il motore specificare:

If the motor is also required, please specify:

- Grandezza - Size es. 90 L4
- Potenza - Power es. Kw 1.5
- Poli - Poles es. 4
- Tensione - Voltage es. V230/400
- Frequenza - Frequency es. 50 Hz
- Flangia - Flange sempre always B5

N.B. I riduttori dalla grandezza 25 alla grandezza 63 vengono sempre forniti in pos. Universale possono quindi essere montati in qualsiasi posizione, dalla grandezza 75 alla grandezza 130 è necessario specificare la pos. se diversa dalla B3. In particolare nel caso in cui un riduttore in B3 vada montato nelle pos. V5 o V6, sarà necessario lubrificare il cuscinetto posto nel lato superiore con grasso apposito che ne garantisca la lubrificazione. Il grasso da noi testato è il Tecnolubeseal POLYMER 400/2.

N.B. From size 25 to 63 the gears are always supplied in the Universal position and can therefore be mounted in any position, from size 75 to size 130 if the position required differs from B3 it must be specified. In particular, in the event that a gear in position B3 is to be mounted in positions V5 or V6, the bearing positioned in the upper side must be lubricated using suitable grease that ensures proper lubrication. We have tested Tecnolubeseal POLYMER 400/2 grease.

	Z	Z1
CHPC 63	11/140	11/105
CHPC 71	14/160	14/120
CHPC 80	19/200	19/160
CHPC 90	24/200	24/160

ATTENZIONE: Il riduttore collegato alla precoppia deve avere dimensioni in entrata Z1

WARNING: The gearbox connected with the pre-stage must have input dimension Z1

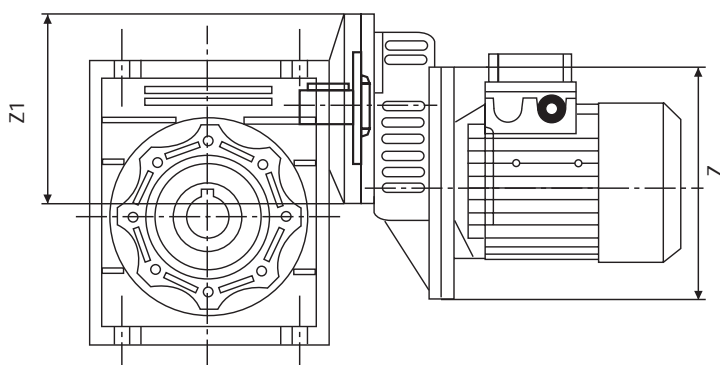

TIPO	i=ratio	n2 r/min	Kw=P1	Nm=T2
TYPE	90	15.6	0.18	61
	120	11.7	0.18	52
CHPC63	150	9.3	0.18	46
CHM040	180	7.8	0.18	46
	240	5.8	0.18	40
	300	4.7	0.18	36

TIPO	i=ratio	n2 r/min	Kw=P1	Nm=T2
TYPE	90	15.6	0.37	153
	120	11.7	0.37	190
CHPC71	150	9.3	0.37	220
CHM075	180	7.8	0.37	236
	240	5.8	0.25	159
	300	4.7	0.25	208

TIPO	i=ratio	n2 r/min	Kw=P1	Nm=T2
TYPE	90	15.6	0.18	69
	120	11.7	0.18	85
CHPC63	150	9.3	0.18	89
CHM050	180	7.8	0.18	88
	240	5.8	0.18	76
	300	4.7	0.18	65

TIPO	i=ratio	n2 r/min	Kw=P1	Nm=T2
TYPE	90	15.6	0.75	307
	120	11.7	0.55	278
CHPC80	150	9.3	0.55	260
CHM075				

TIPO	i=ratio	n2 r/min	Kw=P1	Nm=T2
	90	15.6	0.25	97
CHPC71	120	11.7	0.25	110
CHM050	150	9.3	0.25	112

TIPO	i=ratio	n2 r/min	Kw=P1	Nm=T2
	180	7.8	0.37	260
CHPC71	240	5.8	0.37	320
CHM090	300	4.7	0.37	345

TIPO	i=ratio	n2 r/min	Kw=P1	Nm=T2
TYPE	150	9.3	0.18	101
CHPC63	180	7.8	0.18	115
CHM063	240	5.8	0.18	136
	300	4.7	0.18	121

TIPO	i=ratio	n2 r/min	Kw=P1	Nm=T2
TYPE	90	15.6	0.75	320
CHPC80	120	11.7	0.75	397
CHM090	150	9.3	0.75	426
	180	7.8	0.75	425
	240	5.8	0.55	374

TIPO	i=ratio	n2 r/min	Kw=P1	Nm=T2
TYPE	90	15.6	0.37	145
	90	15.6	0.25	98
CHPC71	120	11.7	0.37	184
CHM063	120	11.7	0.25	124
	150	9.3	0.37	192
	150	9.3	0.25	129
	180	7.8	0.25	164
	240	5.8	0.25	139
	300	4.7	0.25	128

TIPO	i=ratio	n2 r/min	Kw=P1	Nm=T2
TYPE	120	11.7	0.75	421
CHPC80	150	9.3	0.75	496
CHM110	180	7.8	0.75	569
	240	5.8	0.75	617
	300	4.7	0.55	585

TIPO	i=ratio	n2 r/min	Kw=P1	Nm=T2
TYPE	98	14.3	1.50	679
CHPC90	122.5	11.4	1.50	801
CHM110	147	9.5	1.50	810
	147	9.5	1.10	595
	196	7.1	1.10	660

La scelta delle potenze installate è legata all'unificazione dei motori, pertanto talvolta è esuberante rispetto al riduttore, nella selezione verificare sempre la coppia massima indicata, per ogni dubbio contattare il nostro ufficio tecnico.

The choice of power installed is tied to the unification of the motors, therefore it is sometimes in exuberance compared to the gear; always verify the maximum torque indicated when making the selection and if in doubt please contact our technical office.

TIPO	i=ratio	n2 r/min	Kw=P1	Nm=T2
TYPE	98	14.3	1.50	679
CHPC90	122.5	11.4	1.50	813
CHM130	147	9.5	1.50	917
	196	7.1	1.50	1013
	245	5.7	1.10	848

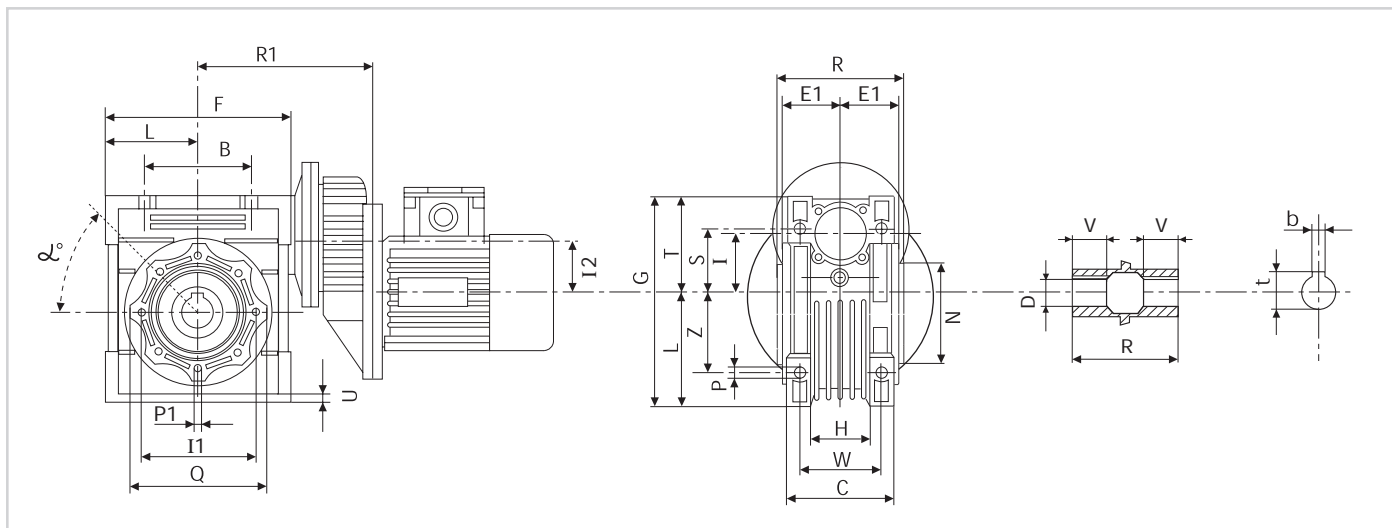

CHPC CHM	B	F	D(H7)	G	H	R1	R	L	I	I2	C	I1	N(h8)	E1	P	Q	S	T
63+040	70	100	18	121.5	43	117	78	50	40	40	71	75	60	36.5	6.5	87	55	71.5
63+050	80	120	25	144	49	127	92	60	50	40	85	85	70	43.5	8.5	100	64	84
71+050	80	120	25	144	49	135	92	60	50	50	85	85	70	43.5	8.5	100	64	84
63+063	100	144	25	174	67	142	112	72	63	40	103	95	80	53	8.5	110	80	102
71+063	100	144	25	174	67	150	112	72	63	50	103	95	80	53	8.5	110	80	102
71+075	120	172	28	205	72	167,5	120	86	75	50	112	115	95	57	11	140	93	119
80+075	120	172	28	205	72	187,5	120	86	75	63	112	115	95	57	11	140	93	119
71+090	140	208	35	238	74	184,5	140	103	90	50	130	130	110	67	13	160	102	135
80+090	140	208	35	238	74	204,5	140	103	90	63	130	130	110	67	13	160	102	135
80(90)+110	170	252.5	42	295	-	235	155	127.5	110	63	144	165	130	74	14	200	125	167.5
80(90)+130	200	292.5	45	335	-	255	170	147.5	130	63	155	215	180	81	16	250	140	187.5

CHPC CHM	U	V	Z	W	P1	α°	b	t	Peso Kg senza motore Weight in kg. excluding motor
63+040	6.5	26	35	60	M6x8n.4	45°	6	20.8	3.9
63+050	7	30	40	70	M8x10n.4	45°	8	28.3	5.2
71+050	7	30	40	70	M8x10n.4	45°	8	28.3	5.8
63+063	8	36	50	85	M8x14n.8	45°	8	28.3	7.9
71+063	8	36	50	85	M8x14n.8	45°	8	28.3	8.5
71+075	10	40	60	90	M8x14n.8	45°	8	31.3	11
80+075	10	40	60	90	M8x14n.8	45°	8	31.3	12.6
71+090	11	45	70	100	M10x18n.8	45°	10	38.3	14.3
80+090	11	45	70	100	M10x18n.8	45°	10	38.3	16.2
80(90)+110	14	50	85	115	M10x18n.8	45°	12	45.3	39
80(90)+130	15	60	100	120	M12x21n.8	45°	14	48.8	67.2

N.B. Per le dimensioni flange laterali e viti bisporgenti consultare serie CHM nella grandezza corrispondente. Vedi pag. 34 e 35.
 N.B. For the side flange and double extended input worm dimensions see the corresponding size of the CHM series.
 See pages 34 and 35.



CHM/CHM-CHME
CHMR/CHM-CHME

RIDUTTORE A VITE SENZA FINE COMBINATO
DOUBLE WORM GEAR



SENSO DI ROTAZIONE

DIRECTION OF ROTATION

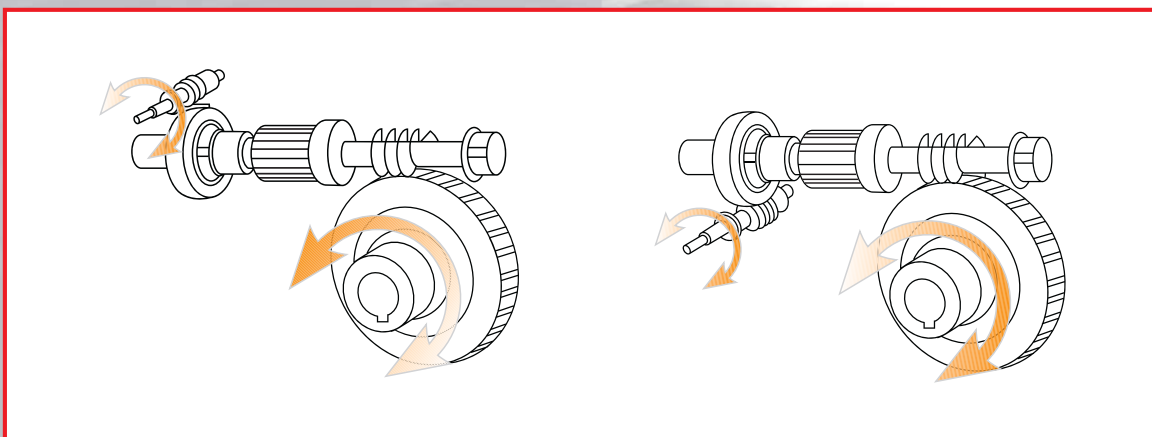

TIPO	GRANDEZZA (1)	VERSIONE (2)	POS. FLANGIA (3)	i	ESEC. (4)	P.A.M.	POS.MONT (3)
TYPE	SIZE (1)	VERSION (2)	FLANGE POS. (3)	i	EXEC. (4)	M.M.F.	MOUNT. POS.
CHM/CHM	025/030	FA	1	300	OAD	Vedi pag. 30 - See page 30	U
CHM/CHME	030/040	FB	2	400	OAS		B3
CHMR/CHM	030/050	FC		500	OBD		B8
CHMR/CHME	030/063	FD		600	OBS		B6
	040/075	FE		750	VAD		B7
	040/090			900	VAS		V5
	050/110			1200	VBD		V6
	063/130			1500	VBS		
				1800			
				2400			

Per le predisposizioni attacco motore (P.A.M.) vedi la tabella predisposizioni possibili. Per le esecuzioni vedi tabella con disegni, se non specificato vengono forniti OBS. La posizione di montaggio si riferisce al secondo riduttore.

For the motor mounting flanges (M.M.F.) see the table showing the types available. For the executions see the table with drawings, if not specified OBS would be supplied. The mounting position refers to the second gear.

ESEMPIO ORDINE - ORDER EXAMPLE

CHM/CHM	040/090	FA(5)	2(5)	500	OAD	63 B14	V5
---------	---------	-------	------	-----	-----	--------	----

Nel caso venga richiesto anche il motore specificare:

If the motor is also required, please specify:

Grandezza - Size	es. 63 B4
Potenza - Power	es. Kw 0.18
Poli - Poles	es. 4
Tensione - Voltage	es. V230/400
Frequenza - Frequency	es. 50 Hz
Flangia - Flange	es. B 14

N.B. I riduttori dalla grandezza 25 alla grandezza 63 vengono sempre forniti in pos. Universale possono quindi essere montati in qualsiasi posizione, dalla grandezza 75 alla grandezza 130 è necessario specificare la pos. se diversa dalla B3.

In particolare nel caso in cui un riduttore in B3 vada montato nelle pos. V5 o V6, sarà necessario lubrificare il cuscinetto posto nel lato superiore con grasso apposito che ne garantisca la lubrificazione.

Il grasso da noi testato è il TecnoLubeseal POLYMER 400/2.

N.B. From size 25 to 63 the gears are always supplied in the Universal position and can therefore be mounted in any position, from size 75 to size 130 if the position required differs from B3 it must be specified.

In particular, in the event that a gear in position B3 is to be mounted in positions V5 or V6, the bearing positioned in the upper side must be lubricated using suitable grease that ensures proper lubrication.

We have tested TecnoLubeseal POLYMER 400/2 grease.

- 1) vedi pagina 48 - see page 48
- 2) vedi da pagina 31 a pagina 40 - see from page 31 to page 40
- 3) vedi pagina 30 - see page 30
- 4) vedi pagina 47 - see page 47
- 5) nessuna indicazione significa che il riduttore è privo di flangia in uscita.
lack of instructions indicates that the gear is not equipped with an output flange.



ESECUZIONE - EXECUTION

OAD

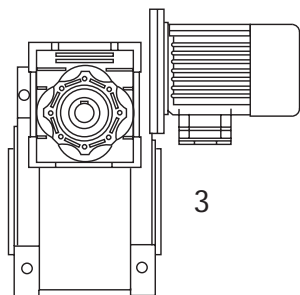

OAS

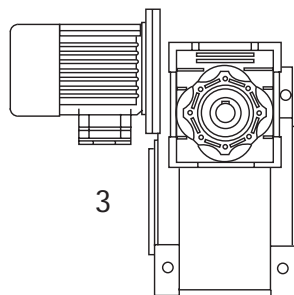

OBD

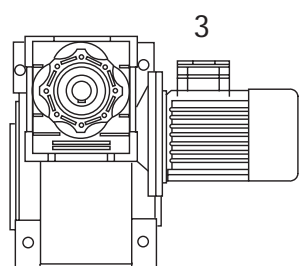

OBS

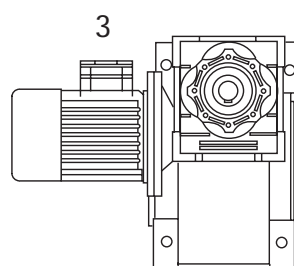

VAD

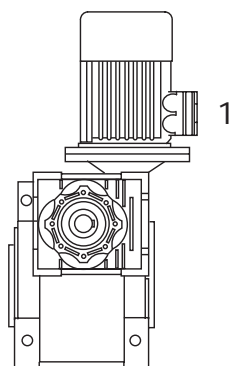

VAS

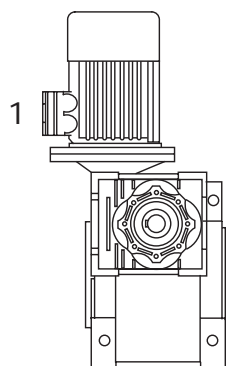

VBS

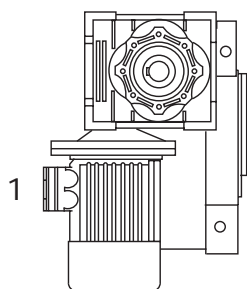

VBD

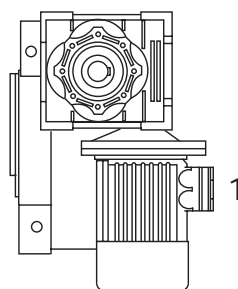

L'esecuzione determina la posizione di montaggio del 1° riduttore rispetto al 2° riduttore. Se non diversamente specificato in fase d'ordine il gruppo viene fornito in esecuzione OBS. La posizione di piazzamento va riferita al 2° riduttore.

The execution determines the mounting position of the first gear in relation to the second gear. If not otherwise specified at the time of order, the group will be supplied in the OBS execution. The placing position refers to the second gear.

TIPO	i=ratio	n2 r/min	Kw=P1	Nm=T2
TYPE	300	4.7	0.09*	31
	400	3.5	0.09*	28
	500	2.8	0.09*	34
	600	2.3	0.09*	31
CHM	750	1.9	0.09*	34
025/030	900	1.6	0.09*	31
	1200	1.2	0.09*	31
	1500	0.9	0.09*	26
	1800	0.8	0.09*	23
	2400	0.6	0.09*	23

TIPO	i=ratio	n2 r/min	Kw=P1	Nm=T2
TYPE	300	4.7	0.37	405
	400	3.5	0.25	336
	500	2.8	0.25	307
	600	2.3	0.18	362
CHM	750	1.9	0.18	391
040/075	900	1.6	0.18*	325
	1200	1.2	0.18*	359
	1500	0.9	0.09	360
	1800	0.8	0.09	404
	2400	0.6	0.09*	330

TIPO	i=ratio	n2 r/min	Kw=P1	Nm=T2
TYPE	300	4.7	0.09*	70
	400	3.5	0.09*	63
	500	2.8	0.09*	57
	600	2.3	0.09*	72
CHM	750	1.9	0.09*	72
030/040	900	1.6	0.09*	73
	1200	1.2	0.09*	65
	1500	0.9	0.09*	73
	1800	0.8	0.09*	73
	2400	0.6	0.09*	65

TIPO	i=ratio	n2 r/min	Kw=P1	Nm=T2
TYPE	300	4.7	0.37	405
	400	3.5	0.37	523
	500	2.8	0.37	550
	600	2.3	0.37	605
CHM	750	1.9	0.25	538
040/090	900	1.6	0.25	533
	1200	1.2	0.18	629
	1500	0.9	0.18	588
	1800	0.8	0.18*	492
	2400	0.6	0.18*	625

TIPO	i=ratio	n2 r/min	Kw=P1	Nm=T2
TYPE	300	4.7	0.18	142
	400	3.5	0.18	127
	500	2.8	0.09	123
	600	2.3	0.09	143
CHM	750	1.9	0.09	148
030/050	900	1.6	0.09*	141
	1200	1.2	0.09*	118
	1500	0.9	0.09*	139
	1800	0.8	0.09*	155
	2400	0.6	0.09*	124

TIPO	i=ratio	n2 r/min	Kw=P1	Nm=T2
TYPE	300	4.7	0.75	871
	400	3.5	0.75	1013
	500	2.8	0.55	984
	600	2.3	0.55	1062
CHM	750	1.9	0.55	1128
050/110	900	1.6	0.37	1079
	1200	1.2	0.25	943
	1500	0.9	0.25	1064
	1800	0.8	0.25	1075
	2400	0.6	0.18	1001

TIPO	i=ratio	n2 r/min	Kw=P1	Nm=T2
TYPE	300	4.7	0.22	210
	400	3.5	0.18	222
	500	2.8	0.18	205
	600	2.3	0.18*	208
CHM	750	1.9	0.18*	216
030/063	900	1.6	0.09	200
	1200	1.2	0.09	236
	1500	0.9	0.09*	204
	1800	0.8	0.09*	202
	2400	0.6	0.09*	220

TIPO	i=ratio	n2 r/min	Kw=P1	Nm=T2
TYPE	300	4.7	1.50	1789
	400	3.5	1.10	1519
	500	2.8	1.10	1629
	600	2.3	0.75	1631
CHM	750	1.9	0.75	1804
063/130	900	1.6	0.75	1826
	1200	1.2	0.55	1705
	1500	0.9	0.37	1674
	1800	0.8	0.37	1698
	2400	0.6	0.25	1624

N.B. Le potenze contrassegnate con * sono superiori a quelle ammissibili dal riduttore, pertanto la scelta applicativa dovrà essere fatta in funzione della coppia e non della potenza. I rapporti di riduzione sono quelli maggiormente richiesti, è possibile ottenere molteplici combinazioni utilizzando i vari rapporti dei due singoli riduttori.

N.B. The powers marked with an asterisk are higher than those that the gear allows, therefore the applicative choice must be made in accordance with the torque and not the power. The gear ratios are those most frequently requested. It is possible to obtain multiple combinations using the various ratios of the two single gears.

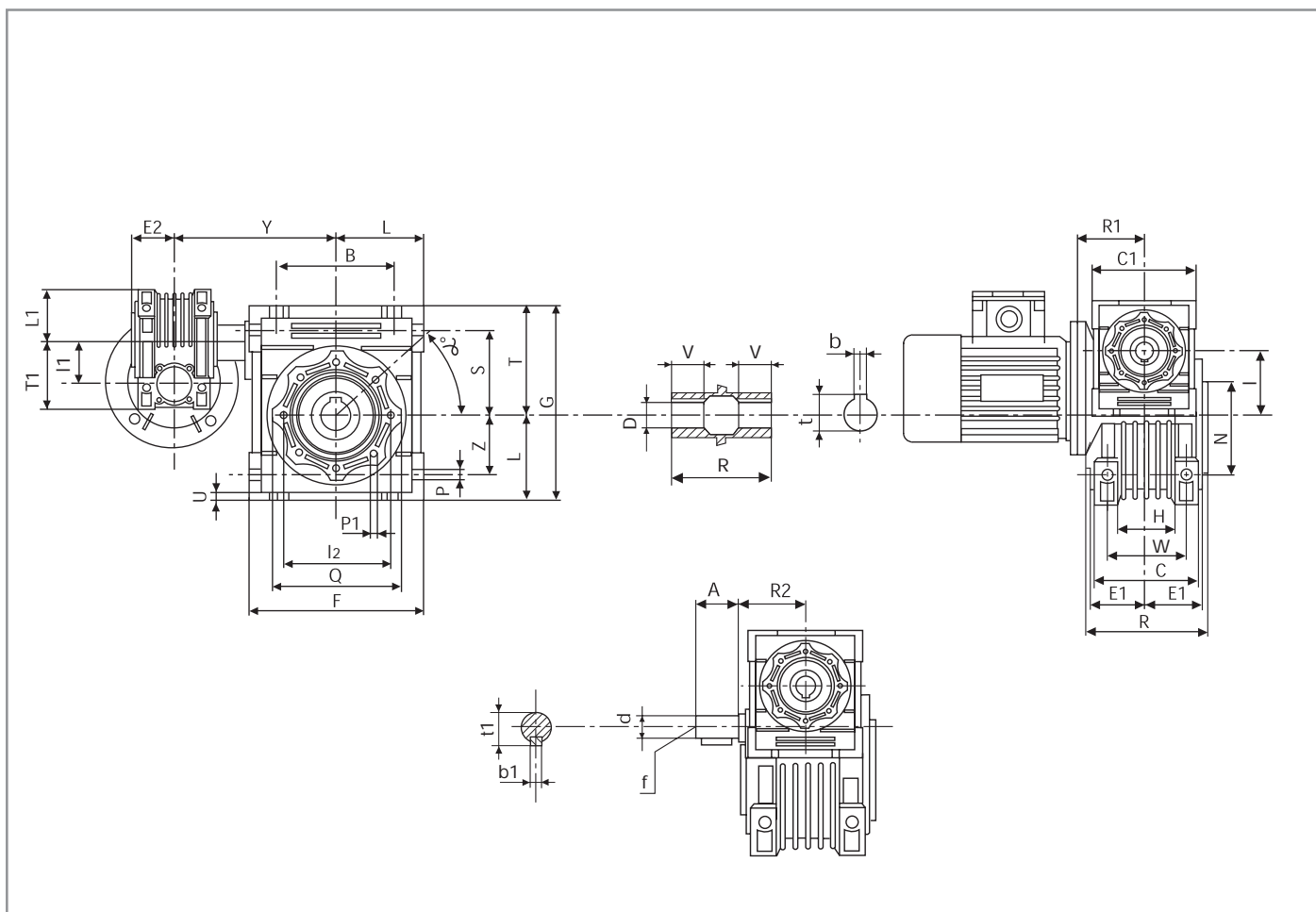

CHM-CHM	B	A	F	C1	D(H7)	d(j6)	G	H	R1	R	R2	L	L1	I	I1	C	I2	N(h8)	E1	E2	P
030/040	70	20	100	80	18	9	121.5	43	55	78	51	50	40	40	30	71	75	60	36.5	29	6.5
030/050	80	20	120	80	25	9	144	49	55	92	51	60	40	50	30	85	85	70	43.5	29	8.5
030/063	100	20	144	80	25	9	174	67	55	112	51	72	40	63	30	103	95	80	53	29	8.5
040/075	120	23	172	100	28	11	205	72	70	120	60	86	50	75	40	112	115	95	57	36.5	11
040/090	140	23	208	100	35	11	238	74	70	140	60	103	50	90	40	130	130	110	67	36.5	13
050/110	170	30	252.5	120	42	14	295	-	80	155	74	127.5	60	110	50	144	165	130	74	43.5	14
063/130	200	40	292.5	144	45	19	335	-	95	170	90	147.5	72	130	63	155	215	180	81	53	16
063/150	240	40	340	144	50	19	400	-	95	200	90	170	72	150	63	185	215	180	96	53	18

CHM-CHM	Q	S	T	T1	U	V	Z	Y	W	P1	α	b	b1	f	t	t1	Peso kg senza motore Weight in Kg. excluding motor
030/040	87	55	71.5	57	6.5	26	35	120	60	M6x8(n.4)	45°	6	3	-	20.8	10.2	3.9
030/050	100	64	84	57	7	30	40	130	70	M8x10(n.4)	45°	8	3	-	28.3	10.2	5.0
030/063	110	80	102	57	8	36	50	145	85	M8x14(n.8)	45°	8	3	-	28.3	10.2	7.8
040/075	140	93	119	71.5	10	40	60	165	90	M8x14(n.8)	45°	8	4	-	31.3	12.5	11.5
040/090	160	102	135	71.5	11	45	70	182	100	M10x18(n.8)	45°	10	4	-	38.3	12.5	15
050/110	200	125	167.5	84	14	50	85	225	115	M10x18(n.8)	45°	12	5	M6	45.3	16.0	39.2
063/130	250	140	187.5	102	15	60	100	245	120	M12x21(n.8)	45°	14	6	M6	48.8	21.5	70
063/150	250	180	230	102	18	72	120	275	145	M12x21(n.8)	45°	14	6	M6	53.8	21.5	100

N.B. Per le dimensioni flange laterali e viti bisporgenti consultare serie CHM nella grandezza corrispondente.

N.B. For the side flange and double extended input worm dimensions see the corresponding size of the CHM models.

BRACCIO DI REAZIONE - TORQUE ARM

TIPO - TYPE	I	R	F	H	Ø E	A	B	Ø C	Ø d	Ø P	N°	Peso cad kit kg Weight for kit kg
CHT MV 25*	70	15	17.5	14	8	33.5	118.5	55	7	45	4	0.17
CHT MV 30*	85	15	24	14	8	38	138	65	7	55	8	0.18
CHT MV 40	100	18	31.5	14	10	44	162	75	7	60	8	0.24
CHT MV 50	100	18	38.5	14	10	50	168	85	9	70	8	0.27
CHT MV 63	150	18	49	14	10	55	223	95	9	80	8	0.57
CHT MV 75	200	30	47.5	25	20	70	300	115	9	95	8	1.10
CHT MV 90	200	30	57.5	25	20	80	310	130	11	110	8	1.26
CHT MV 110	250	35	62	30	25	100	385	165	11	130	8	1.92
CHT MV 130/150	250	35	69	30	25	125	410	215	14	180	8	2.23

* Privo di boccola antivibrante
* Without vibration resistant bushing

Il punto di ancoraggio del braccio di reazione è dotato di boccola antivibrante.

The anchoring point of the torque arm is equipped with a vibration resistant bushing.

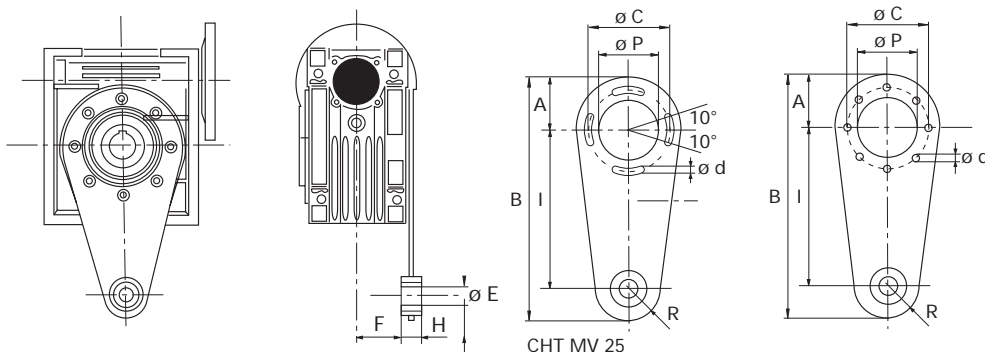

KIT ALBERO LENTO SEMPLICE - SINGLE OUTPUT SHAFT KIT

TIPO - TYPE	A	Ø d	B	b	t 1	T	L	d 2	Peso cad kit kg Weight for kit kg
CHT MVS 25	23	11	25.5	4	12.5	55.5	81	-	0.07
CHT MVS 30	30	14	32.5	5	16	69.5	102	M6x16	0.14
CHT MVS 40	40	18	43	6	20.5	85	128	M6x16	0.27
CHT MVS 50	50	25	53.5	8	28	99.5	153	M10x22	0.60
CHT MVS 63	50	25	53.5	8	28	119.5	173	M10x22	0.67
CHT MVS 75	60	28	63.5	8	31	128.5	192	M10x22	0.94
CHT MVS 90	80	35	84.5	10	38	149.5	234	M12x28	1.79
CHT MVS 110	80	42	84.5	12	45	164.5	249	M16x35	2.70
CHT MVS 130	80	45	85	14	48.5	180	265	M16x35	3.60
CHT MVS 150	82	50	87	14	53.5	210	297	M16x35	5.00

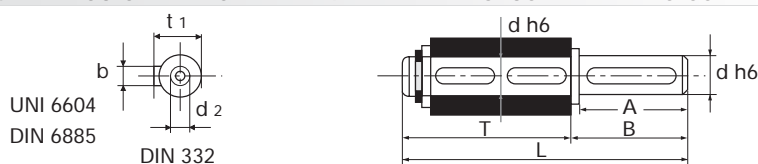

KIT ALBERO LENTO DOPPIO - DOUBLE OUTPUT SHAFT KIT

TIPO - TYPE	A	Ø d	B	R	b	t 1	L	d 2	Peso cad kit kg Weight for kit kg
CHT MVD 25	23	11	25.5	50	4	12.5	101	-	0.11
CHT MVD 30	30	14	32.5	63	5	16	128	M6x16	0.16
CHT MVD 40	40	18	43	78	6	20.5	164	M6x16	0.34
CHT MVD 50	50	25	53.5	92	8	28	199	M10x22	0.75
CHT MVD 63	50	25	53.5	112	8	28	219	M10x22	0.84
CHT MVD 75	60	28	63.5	120	8	31	247	M10x22	1.20
CHT MVD 90	80	35	84.5	140	10	38	309	M12x28	2.50
CHT MVD 110	80	42	84.5	155	12	45	324	M16x35	3.44
CHT MVD 130	80	45	85	170	14	48.5	340	M16x35	4.25

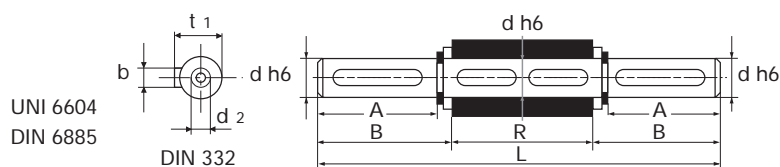

COPRIMOZZO CORONA - COVER

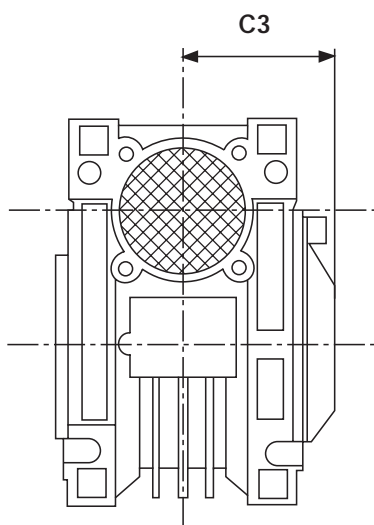

TIPO - TYPE	C3
030	43
040	50
050	59
063	70
075	75
090	87
110	95
130/150	103

KIT BOCCOLE DI RIDUZIONE - REDUCTION BUSHINGS KIT

SEMPLICE - SINGLE

TIPO TYPE	$\varnothing i / \varnothing e$	L	linguette Key	Peso cad kit kg Weight for kit kg
CHT BRM-S	9/11	20	4/3x4x11 RB*	0.006
CHT BRM-S	11/14	30	5/4x6x10 RB*	0.015
CHT BRM-S	14/19	40	6x5x30 *	0.045
CHT BRM-S	19/24	50	6x5.5x20 * 8x5.5x40 *	0.07
CHT BRM-S	24/28	60	8x9x40 *	0.08
CHT BRM-S	28/38	80	10x7x60 *	0.33
CHT BRM-S	38/42	110	12/10x10x48 RB*	0.22

DOPPIO - DOUBLE

TIPO TYPE	$\varnothing i / \varnothing e$	L	linguette Key	Peso cad kit Weight for kit kg
CHT BRM-D	11/19	40	6x6x30 *	0.06
CHT BRM-D	14/24	50	8x7x40 A	0.12
CHT BRM-D	19/28	60	8x7x50 A	0.16
CHT BRM-D	24/38	80	10x8x60 A	0.44

* a disegno
* to drawing

Linguetta sec UNI 6604 - DIN 6885
Bonificate

Tongue acc. to UNI 6604 - DIN 6885
Quenched

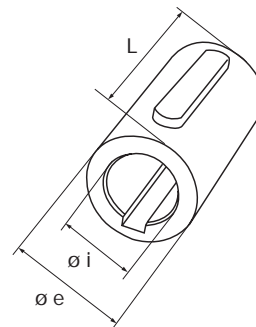
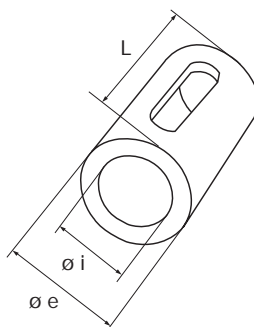

I carichi indicati valgono in qualunque direzione di applicazione.

I carichi assiali massimi ammissibili sono pari a 1/5 del valore del carico radiale indicato in tabella quando sono applicati in combinazione con il carico radiale stesso, in caso diverso vi preghiamo di contattare il ns. ufficio tecnico.

Se vengono utilizzati alberi lenti doppi, la somma dei carichi radiali applicabili alle mezzerie delle due estremità d'albero, non devono superare il valore indicato nella tabella sottoindicata.

I carichi radiali riferiti ai giri di uscita (n2)=10 sono i massimi sopportabili dal riduttore.

The loads indicated are valid for all application directions.

The maximum allowable axial loads are equal to 1/5 of the radial load value shown in the table when applied with the same radial load; if this is not the case, please contact our technical office. If double output shafts are used, the sum of radial loads applicable to the centre lines of the two ends of the shaft must not exceed the value shown in the table below.

The radial loads related to the output speed (n2)=10 are the maximum loads supported by the gear.

- a • Costante del riduttore
- b • Costante del riduttore
- x • Distanza del carico dalla battuta dell'albero in mm.
- F_{RX} • Carico radiale nella posizione x (in N)
- F_R • Carico radiale (N)
- F_A • Carico assiale (N)

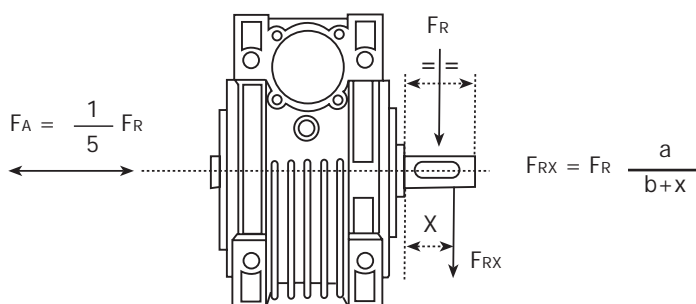

- a • Gear constant
- b • Gear constant
- x • Load distance from shaft shoulder in mm.
- F_{RX} • Radial load in position x (in N)
- F_R • Radial load (N)
- F_A • Axial load (N)

GRANDEZZE - SIZES

Giri di uscita Output speed (n2)	025	030	040	050	063	075	090	110	130	150
400	390	530	1020	1400	1830	2160	2390	3530	3950	5290
250	460	620	1200	1650	2150	2520	2800	4130	4610	6140
150	550	740	1420	1960	2540	2990	3310	4890	5470	7300
100	630	850	1620	2250	2910	3430	3800	5600	6260	8330
60	740	1000	1920	2660	3450	4060	4500	6640	7420	9800
40	850	1150	2200	3050	3950	4650	5150	7600	8500	11330
25	990	1350	2570	3570	4620	5440	6020	8890	9940	13250
10	1350	1830	3490	4840	6270	7380	8180	12000	13500	18000

VALORI DELLE COSTANTI - CONSTANTS' VALUES

a	50	65	84	101	120	131	162	176	188	215
b	38	50	64	76	95	101	122	136	148	174



CARICHI RADIALI SULLA MEZZERIA DELL'ALBERO VELOCE RADIAL LOADS ON THE CENTRE LINE OF THE INPUT SHAFT

$$F_{RX} = F_R \frac{a}{b+x}$$

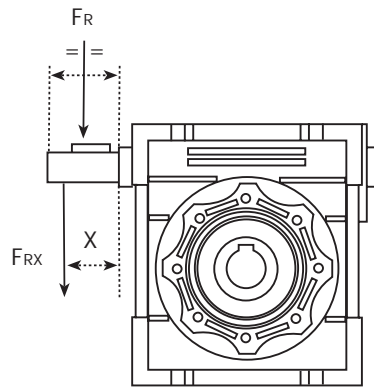

GRANDEZZE - SIZES

	030	040	050	063	075	090	110	130	150
VALORI DELLE COSTANTI - CONSTANTS' VALUES									
a	86	106	129	159	192	227	266	314	350
b	76	94	114	139	167	202	236	274	310
Fr max	210	350	490	700	980	1270	1700	2100	2800

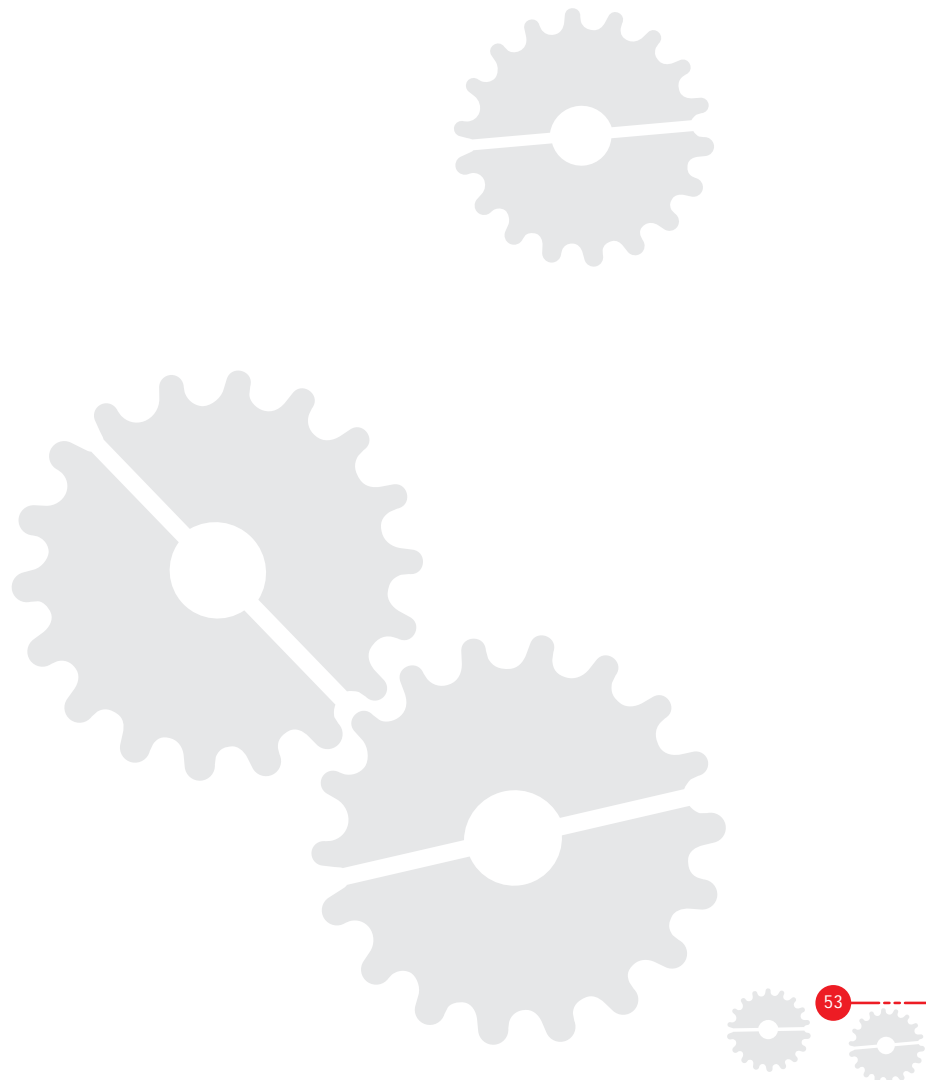

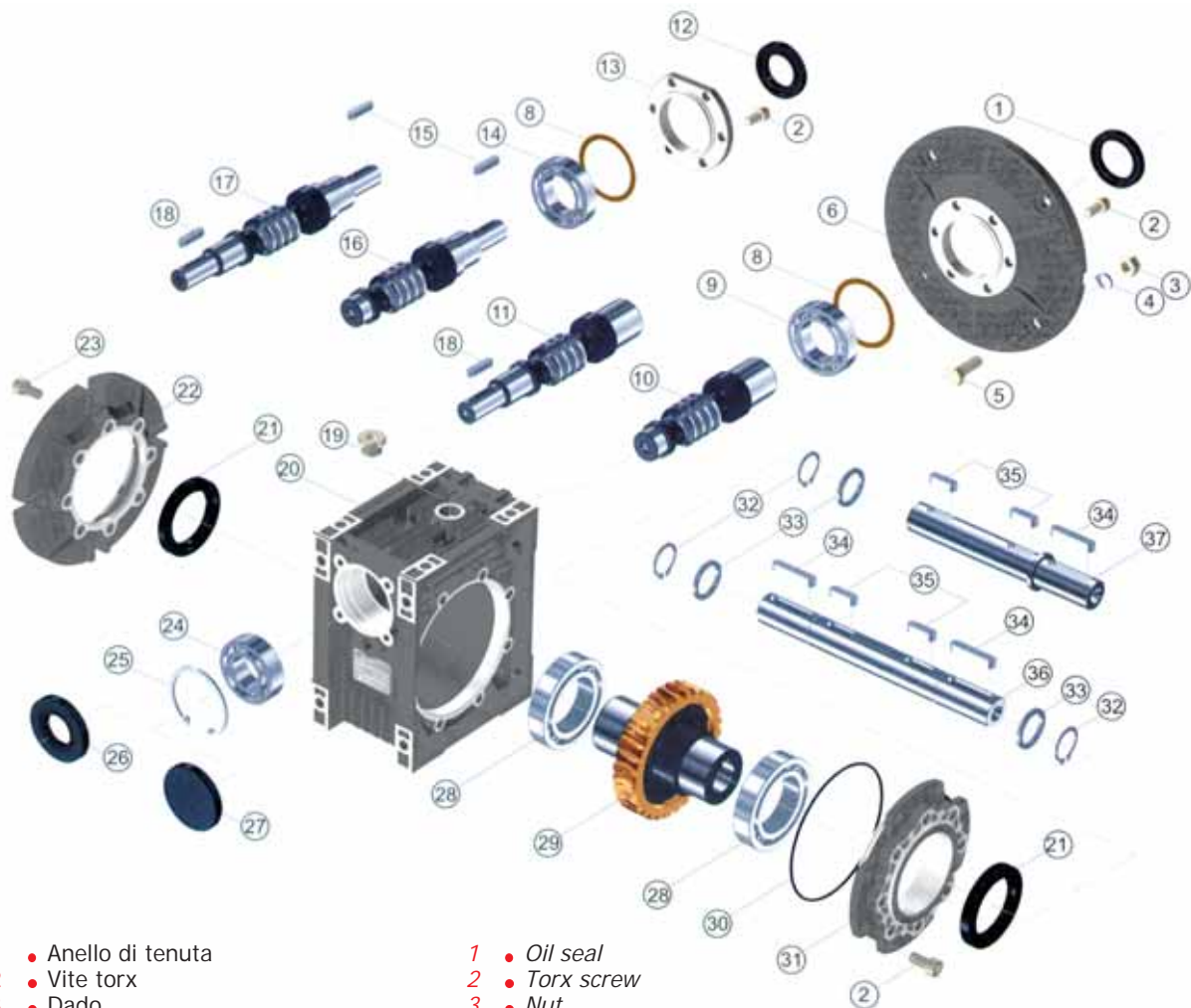

- 1 • Anello di tenuta
- 2 • Vite torx
- 3 • Dado
- 4 • Rondella
- 5 • Vite testa esagonale
- 6 • Flangia attacco motore
- 8 • Rasamento
- 9 • Cuscinetto
- 10 • Vite p.a.m.
- 11 • Vite p.a.m. + sporgenza
- 12 • Anello di tenuta
- 13 • Coperchio entrata
- 14 • Cuscinetto
- 15 • Chiavetta
- 16 • Vite sporgente
- 17 • Vite bisporgente
- 18 • Chiavetta
- 19 • Tappo olio
- 20 • Cassa
- 21 • Anello di tenuta
- 22 • Flangia uscita
- 23 • Vite testa esagonale incassata
- 24 • Cuscinetto
- 25 • Seeger
- 26 • Anello di tenuta
- 27 • Cappello
- 28 • Cuscinetto
- 29 • Corona
- 30 • O-ring
- 31 • Coperchio uscita
- 32 • Seeger
- 33 • Distanziale
- 34 • Chiavetta
- 35 • Chiavetta
- 36 • Albero lento doppio
- 37 • Albero lento semplice

- 1 • Oil seal
- 2 • Torx screw
- 3 • Nut
- 4 • Washer
- 5 • Hexagonal-head screw
- 6 • Motor connection flange
- 8 • Adjust spacer
- 9 • Bearing
- 10 • Hole input worm
- 11 • Hole input and shaft output worm
- 12 • Oil seal
- 13 • Input cover
- 14 • Bearing
- 15 • Key
- 16 • Shaft input worm
- 17 • Double extended input shaft worm
- 18 • Key
- 19 • Oil plug
- 20 • Casing
- 21 • Oil seal
- 22 • Output flange
- 23 • Embedded hexagonal-head screw
- 24 • Bearing
- 25 • Seeger
- 26 • Oil seal
- 27 • Cap
- 28 • Bearing
- 29 • Worm wheel
- 30 • O-ring
- 31 • Output cover
- 32 • Seeger
- 33 • Spacer
- 34 • Key
- 35 • Key
- 36 • Double output shaft
- 37 • Single output shaft

INSTALLAZIONE

- I dati riportati sulla targhetta identificativa devono corrispondere al riduttore ordinato.
- Il livello dell'olio, per le grandezze 110 e 130 provviste di tappi di carico, scarico e livello, dovrà corrispondere alla quantità prevista per la posizione di montaggio richiesta (vedi catalogo), inoltre sempre per le grandezze indicate, sarà cura del cliente sostituire il tappo chiuso di carico, fornito per il trasporto, con il corrispondente previsto di foro di sfianto dato in dotazione al riduttore.
- Tutti gli altri riduttori vengono forniti completi di olio sintetico permanente in quantità idonea a qualsiasi posizione di montaggio.
- Il fissaggio del riduttore deve avvenire su superfici piane e sufficientemente rigide in modo da evitare qualsiasi vibrazione.
- Il riduttore e l'asse della macchina da movimentare devono essere in perfetto allineamento.
- In caso si prevedano urti, sovraccarichi o blocchi della macchina il cliente dovrà provvedere all'installazione di limitatori, giunti, salvamotori etc.
- Gli accoppiamenti con pignoni, giunti, pulegge ed altri organi devono essere fatti previa pulizia delle parti ed evitando urti nel montaggio poiché questo potrebbe danneggiare i cuscinetti ed altre parti interne.
- Nel caso il motore sia di fornitura del cliente questi dovrà accertarsi che le tolleranze di flangia ed albero corrispondono ad una classe "normale", i nostri motori rispondono a questa esigenza.
- Verificare che le viti di fissaggio del riduttore e dei relativi accessori siano correttamente serrate.
- Adottare gli opportuni accorgimenti per proteggere i gruppi da eventuali agenti atmosferici aggressivi.
- Dove previsto proteggere le parti rotanti da possibili contatti con gli operatori.
- Nel caso i riduttori vengano verniciati proteggere gli anelli di tenuta ed i piani lavorati.
- Tutti i riduttori sono verniciati colore grigio RAL 9022.

FUNZIONAMENTO E RODAGGIO

- Per ottenere le migliori prestazioni è necessario provvedere ad un adeguato rodaggio dei riduttori incrementando la potenza gradualmente nelle prime ore di funzionamento, in questa fase un aumento delle temperature è da considerarsi nella norma.
- In caso di funzionamento difettoso, rumorosità, perdite olio etc. arrestare immediatamente il riduttore e, dove possibile, rimuovere la causa, in alternativa inviare il pezzo alla nostra sede per i controlli.

MANUTENZIONE

- I riduttori a vite senza fine dalla grandezza 25 alla grandezza 90 e le precopie sono lubrificate con olio sintetico permanente, pertanto non richiedono alcuna manutenzione.
- I riduttori grandezza 110 e 130 sono lubrificati con olio minerale e dotati di tappo di sfianto, pertanto periodicamente andrà verificato il livello dell'olio ed eventualmente aggiunto utilizzando un olio uguale o compatibile con quelli indicati sul nostro catalogo.
- Nei riduttori grandezza 110 e 130 procedere alla sostituzione dell'olio dopo le prime 300 ore lavorative ripristinando la giusta quantità, rilevabile dal nostro catalogo a seconda della posizione di montaggio, dopo accurato lavaggio interno del riduttore.

CONSERVAZIONE A MAGAZZINO

- Nel caso di lunga conservazione a magazzino, superiore a tre mesi, si consiglia di proteggere alberi e piani lavorati con antiossidanti e di ingrassare gli anelli di tenuta.

MOVIMENTAZIONE

- Nella movimentazione dei gruppi dovrà essere posta molta attenzione a non danneggiare gli anelli di tenuta ed i piani lavorati.

SMALTIMENTO IMBALLI

- Gli imballi in cui vengono consegnati i nostri riduttori andranno avviati, dove possibile, al riciclo degli stessi tramite le ditte preposte.

INSTALLATION

- *The data shown on the identification name plate must correspond to the gear ordered.*
- *The oil level, for the sizes 110 and 130 equipped with filling, draining and level plug, must correspond to the quantity foreseen for the assembly position requested (see catalogue), in addition, always for the sizes indicated, it will be the client's responsibility to substitute the blind plug, supplied for transport, with the corresponding plug equipped with a bleed hole included in the supply with the gear.*
- *All of the other gears are supplied complete with permanent synthetic oil in a quantity that is sufficient for any assembly position.*
- *The gear must be fixed on a flat surface that is sufficiently rigid in order to avoid any vibration.*
- *The gear and the axis of the machine to be driven must be perfectly aligned.*
- *In the event that knocks, overloading or blockage of the machine are foreseen, the client must install a limiting device, joints, overload cut-out etc.*
- *Coupling with pinions, joints, pulleys and other parts must be done after the parts have been cleaned and knocks should be avoided while assembling as they could damage the bearings and other internal parts.*
- *In the event that the motor is supplied by the client, he must check that the flange and shaft tolerances correspond to a "normal" class; our motors satisfy this requirement.*
- *Check that the fixing screws for the gear and the related accessories are correctly tightened.*
- *Take suitable measures to protect the groups from any aggressive atmospheric agents.*
- *Where foreseen, protect rotating parts from any possible contact with the operators.*
- *If the gears are painted, protect the oil seals and the machined surfaces.*
- *All of the gears are painted RAL 9022 grey.*

OPERATION AND RUNNING-IN

- *To obtain the best performance the gears must first be run-in by gradually increasing the power in the first few hours of operation, in this phase an increase in temperature is considered normal.*
- *In the event of defective operation, noise, oil leakage, etc. stop the gear immediately and, when possible, remove the cause. Alternatively, send the piece to our factory to be controlled.*

MAINTENANCE

- *The worm gears from size 25 to size 90 and the pre-stage modules are lubricated with permanent synthetic oil and therefore do not require any maintenance.*
- *The gears size 110 and 130 are lubricated with mineral oil and are equipped with a breather plug, therefore the oil level must be checked periodically and if necessary topped up with the same oil or one that is compatible with those indicated in our catalogue.*
- *For the gears size 110 and 130 proceed with the substitution of the oil after the first 300 working hours, replacing it with the correct quantity in accordance with the assembly position, as detailed in our catalogue, after the inside of the gear has been thoroughly washed.*

WAREHOUSE STORAGE

- *If the warehouse storage will be for a long time, more than 3 months, the shafts and machined surfaces should be protected using antioxidants and the oil seals should be greased.*

HANDLING

- *Care must be taken not to damage the oil seals and the machined surfaces when handling the groups.*

DISPOSAL OF PACKAGING

- *The packaging in which our gears are delivered should be sent to specialised companies for recycling if possible.*