

UNIVERSAL SHAFTS

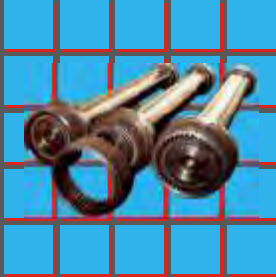

ORGANI DI TRASMISSIONE

GEAR SPINDLES



GEAR REDUCERS



260 B



GEAR COUPLINGS



270 C

GIUNTI A DENTI PER ALTE VELOCITÀ HIGH SPEED GEAR COUPLINGS



272 B

OUR PRODUCTION PROGRAM

| | |
|---------------------------|-----------------|
| GEAR SPINDLES | CATALOGUE 197 C |
| GEAR REDUCERS | CATALOGUE 260 B |
| GEAR COUPLINGS | CATALOGUE 270 C |
| HIGH SPEED GEAR COUPLINGS | CATALOGUE 272 B |

CONTENTS

| | |
|--|------------|
| ENGINEERING AND MANUFACTURING | page 3 |
| ENGINEERING DATA - SERIES A | page 4/5 |
| ENGINEERING DATA - SERIES B | page 6/7 |
| ENGINEERING DATA - SERIES C | page 8/9 |
| ENGINEERING DATA - SERIES S | page 10/11 |
| ENGINEERING DATA - SERIES D - SERIES G | page 12/13 |
| ENGINEERING DATA - SERIES F - SERIES J | page 14/15 |
| ENGINEERING DATA - SERIES E - SERIES H | page 16/17 |
| COMPANION FLANGES WITH INNER CENTERING | page 18/19 |
| COMPANION FLANGES WITH OUTER CENTERING | page 20/21 |
| CYLINDRICAL COMPANION FLANGES WITH INNER CENTERING | page 22/23 |
| CYLINDRICAL COMPANION FLANGES WITH OUTER CENTERING | page 24/25 |
| BORE DESIGNS | page 26 |
| ENGINEERING DATA - SPECIAL AND EXTRA LARGE FLANGES | page 27 |
| ENGINEERING DATA - HIRTH SERRATION | page 28 |
| ENGINEERING DATA - DOG TEETH | page 29 |
| ENGINEERING DATA - FLANGE BOLTING | page 30 |
| ENGINEERING DATA - JOURNAL CROSS ASSEMBLIES | page 31 |
| DESIGN VARIATIONS | page 32/33 |
| OPERATING PRINCIPLES | page 34 |
| SIZE SELECTION | page 35/40 |
| ENGINEERING DATA - WEIGHTS | page 41 |
| ENGINEERING DATA - MASS MOMENTS OF INERTIA | page 42 |
| UNIVERSAL SHAFT IDENTIFICATION | page 43 |
| COMPANION FLANGE IDENTIFICATION | page 44 |
| INSTALLATION, MAINTENANCE AND LUBRICATION | page 45/47 |
| SPARE PART IDENTIFICATION | page 48/49 |
| TORQUE MONITORING | page 50 |
| TECHNICAL DATA FOR SELECTION | page 51/52 |

The present catalogue relates to MAINA's present production of Universal Shafts, and provides a description of their technical specification in order for a proper selection to be made.

Our engineers are however always at your disposal to make suggestions for your choice and provide you with any further information requested.

The present edition supersedes any previous edition.

MAINA RESERVE THE RIGHT TO CHANGE ANY TECHNICAL SPECIFICATION CONTAINED HEREIN, WITHOUT NOTICE.
Any reproduction, even partial, of the present catalogue violates the copyright and will therefore be persecuted.

© Copyright 2009
MAINA - Organi di Trasmissione S.p.A. - Asti - Italy

Printed by CARRER - Asti - Italy

MAINA PATTERN IS GUARANTEED BY:

Design and experience we have made in cooperation with all the industrial plant maintenance managers. This has led to manufacture the monolithic yoke design. All our universal shafts have been designed and developed by MAINA technical department. Our skilled engineers can also propose and project very special solutions, able to fit the customer's requirements, yet maintaining the basis project features.

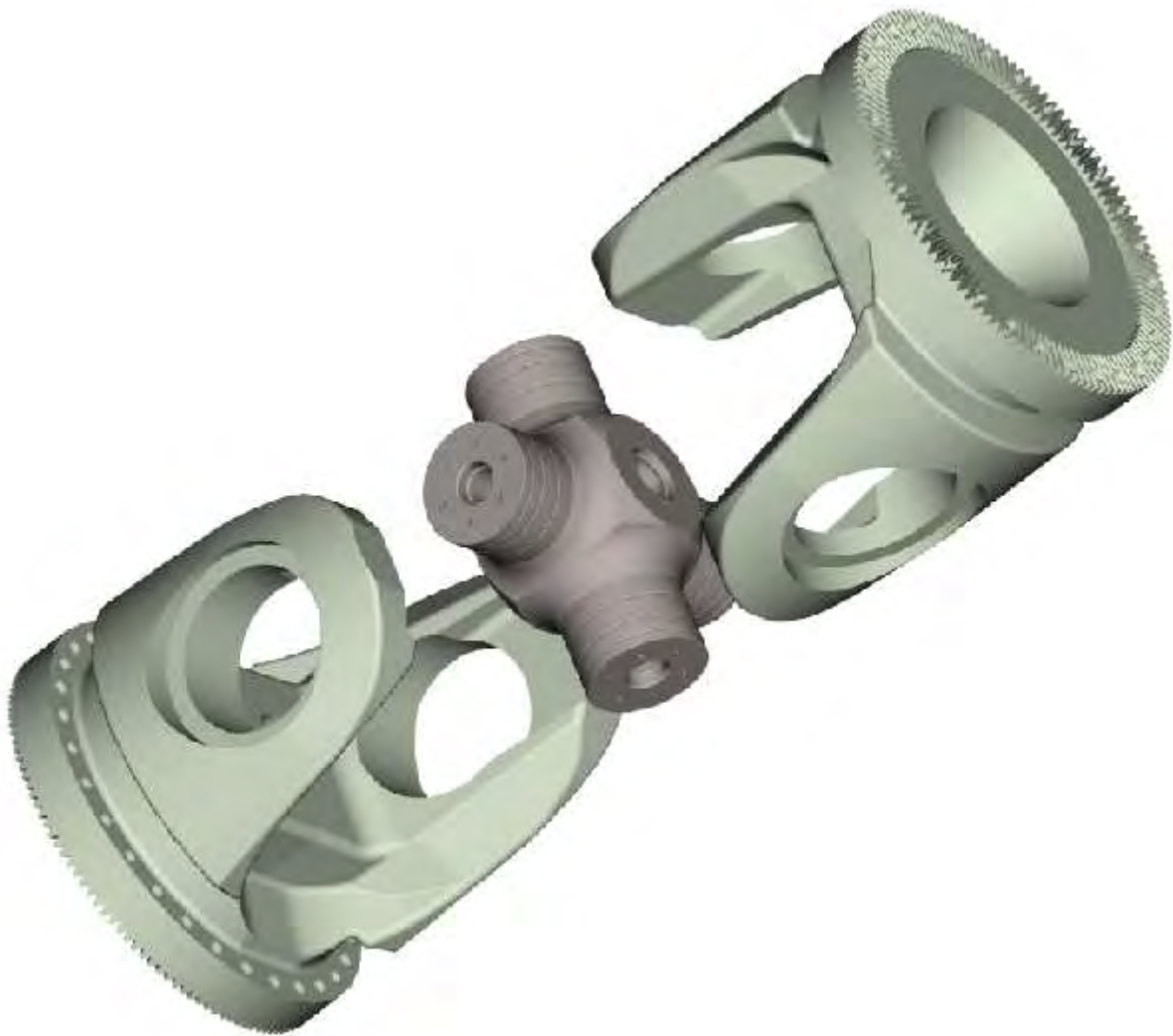

SERIES A

ENGINEERING DATA

TYPE

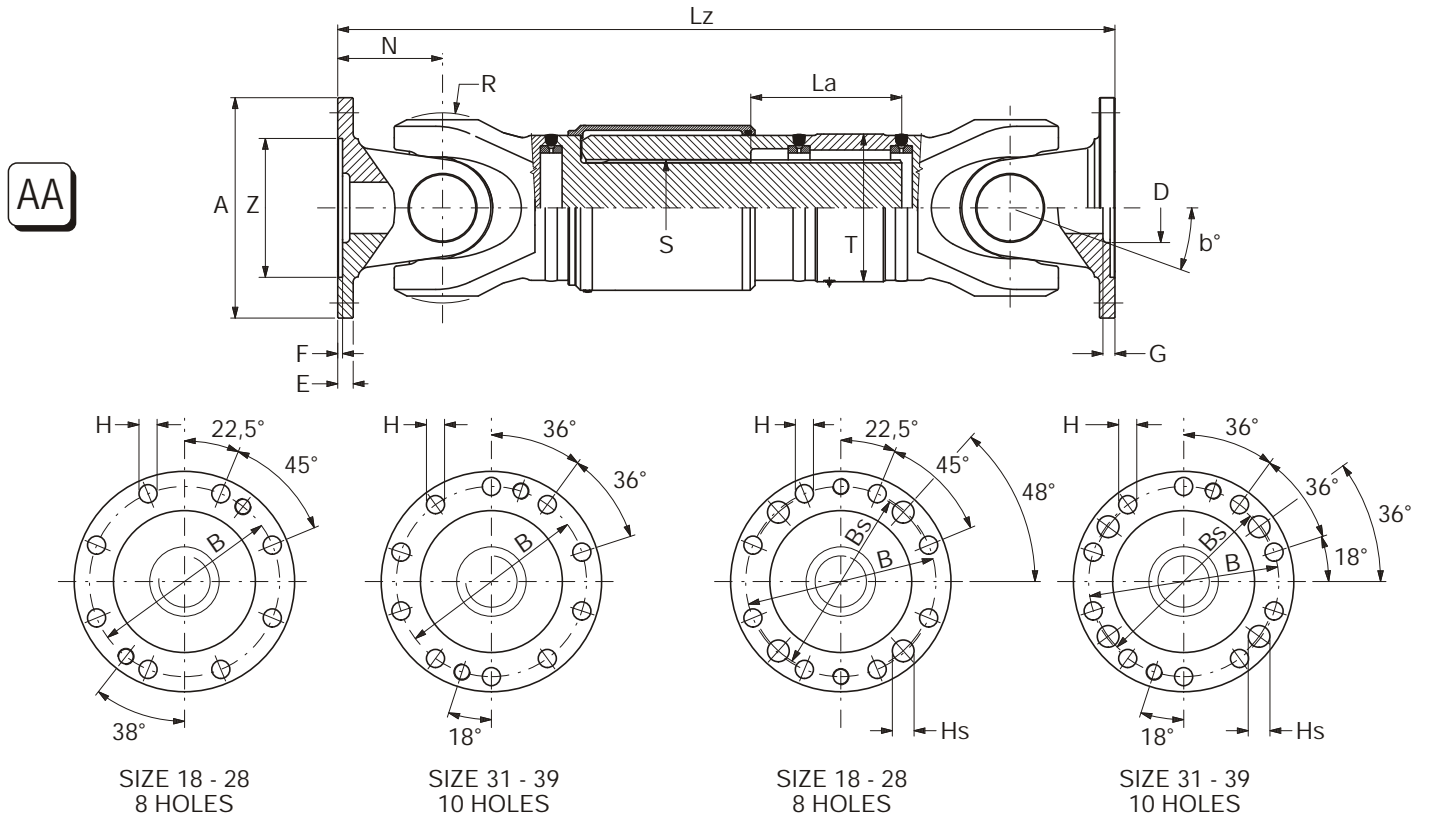

STANDARD FLANGE CONNECTION

DOWEL PIN CONNECTION ACCORDING TO DIN 15451

TYPE

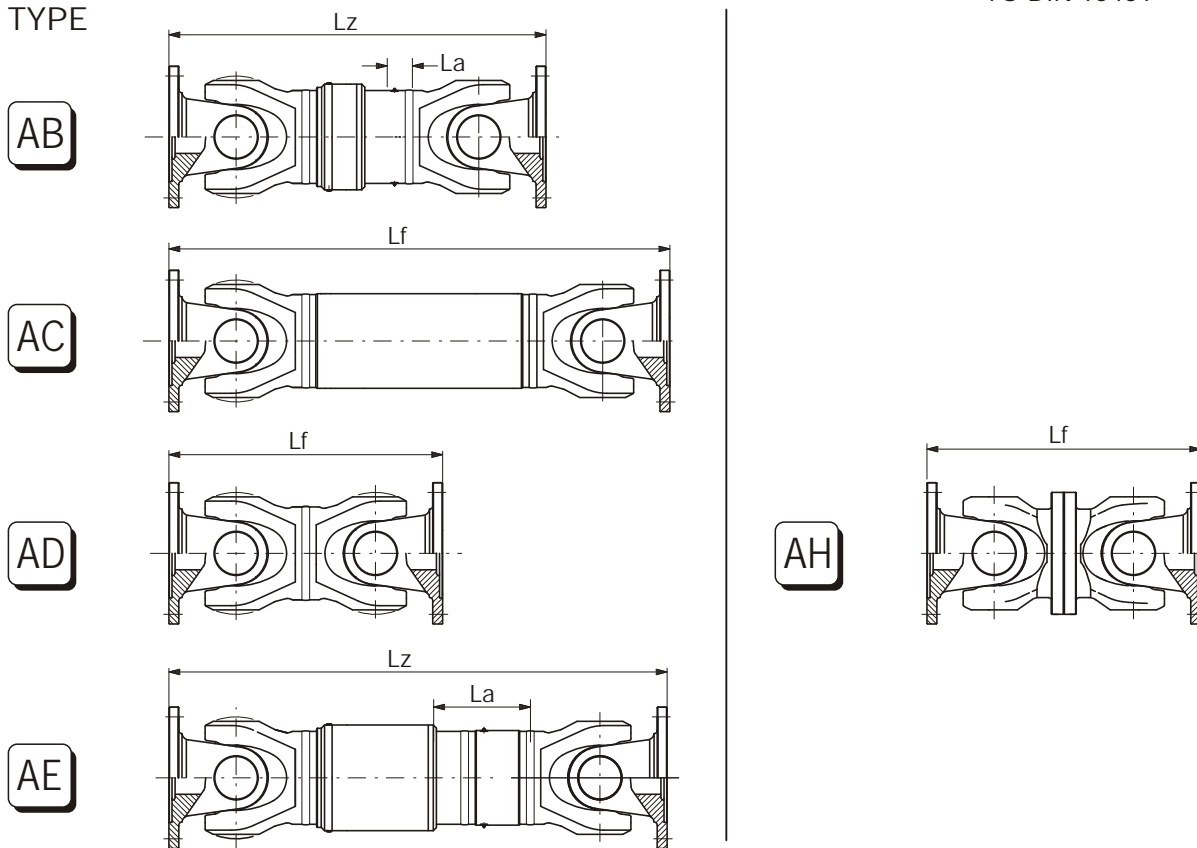

ENGINEERING DATA
SERIES A
TYPE

AA - Telescopic Shaft, medium length compensation
 AB - Telescopic Shaft, short length compensation, short design
 AC - Fix Length Shaft, tubular design

AD - Fix Length Shaft, short design
 AE - Telescopic Shaft, long length compensation
 AH - Fix Length Shaft, flange short design

TABLE 1

| SIZE | | 18 | 22 | 25 | 28 | 31 | 35 | 39 | |
|-------------------------------------|---|-------|-------|-------|-------|-------|-------|-------|------|
| RATING TORQUES | | | | | | | | | |
| Mk [⊗] | [kNm] | 21 | 40 | 48 | 71 | 103 | 146 | 196 | |
| MDSch [⊗] | [kNm] | 15 | 26 | 38 | 58 | 85 | 116 | 156 | |
| MDw [⊗] | [kNm] | 10 | 18 | 24 | 37 | 54 | 76 | 103 | |
| STANDARD DIMENSIONS | | | | | | | | | |
| A ^① | [mm] | 225 | 250 | 285 | 315 | 350 | 390 | 435 | |
| b° |  | 15 | 15 | 15 | 15 | 15 | 15 | 15 | |
| B ^② | [mm] | 196 | 218 | 245 | 280 | 310 | 345 | 385 | |
| Bs | [mm] | 192 | 214 | 240 | 270 | 300 | 340 | 378 | |
| Z (H7) | [mm] | 140 | 140 | 175 | 175 | 220 | 250 | 280 | |
| F | [mm] | 5 | 6 | 7 | 7 | 8 | 8 | 8 | |
| E | [mm] | 15 | 18 | 20 | 22 | 25 | 32 | 32 | |
| H (C12) | [mm] | 16 | 18 | 20 | 22 | 22 | 24 | 27 | |
| Hs (H12) | [mm] | 21 | 25 | 28 | 30 | 32 | 32 | 35 | |
| G | [mm] | 15 | 15 | 15 | 16 | 16 | 18 | 20 | |
| D | [mm] | 80 | 90 | 90 | 110 | 115 | 140 | 155 | |
| R | [mm] | 180 | 225 | 250 | 285 | 315 | 350 | 390 | |
| N | [mm] | 110 | 120 | 140 | 160 | 180 | 195 | 210 | |
| S DIN 5480 ^③ | | 90x3 | 110x3 | 130x4 | 140x4 | 180x5 | 190x5 | 210x6 | |
| T | [mm] | 139.7 | 152.4 | 177.8 | 203 | 254 | 298.5 | 323.9 | |
| LENGTH / LENGTH COMPENSATION | | | | | | | | | |
| AA | Lz min | [mm] | 795 | 855 | 985 | 1080 | 1235 | 1350 | 1495 |
| | La std | [mm] | 140 | 145 | 150 | 155 | 160 | 170 | 180 |
| | Lz max | [mm] | 1205 | 1310 | 1485 | 1625 | 1875 | 2080 | 2315 |
| | La max | [mm] | 550 | 600 | 650 | 700 | 800 | 900 | 1000 |
| AB | Lz min | [mm] | 615 | 685 | 795 | 900 | 1045 | 1175 | 1350 |
| | La std | [mm] | 40 | 50 | 50 | 60 | 65 | 65 | 70 |
| AC | Lf | [mm] | 495 | 535 | 615 | 695 | 780 | 835 | 930 |
| | Lf max | [mm] | 1205 | 1310 | 1485 | 1625 | 1875 | 2080 | 2315 |
| | Lf lim | [mm] | 3280 | 4000 | 4720 | 5020 | 5740 | 6450 | 7170 |
| AD | Lf | [mm] | 440 | 480 | 560 | 640 | 720 | 780 | 840 |
| AE | Lz min | [mm] | 985 | 1050 | 1180 | 1295 | 1495 | 1620 | 1775 |
| | La std | [mm] | 280 | 290 | 300 | 310 | 320 | 340 | 360 |
| | Lz max | [mm] | 1505 | 1610 | 1880 | 2085 | 2375 | 2680 | 2915 |
| | La max | [mm] | 800 | 850 | 1000 | 1100 | 1200 | 1400 | 1500 |
| | Lz lim | [mm] | 3280 | 4000 | 4720 | 5020 | 5740 | 6450 | 7170 |
| AH | Lf | [mm] | 440 | 480 | 560 | 640 | 720 | 780 | 840 |

Lz min = shortest length corresponding to La std
 La std = standard length compensation
 Lz max = shortest length corresponding to La max
 La max = maximum length compensation
 Lz lim = maximum length of universal shaft

When Lz ≠ Lz min, then Lz = Lz min + (La - La std)

Lz max, Lz lim, Lf max, Lf lim valid if max allowable speed or torsional stiffness do not create any problem.

Lf = fix length

Lf min = minimum fix length

Lf max = maximum fix length with standard tube

Lf lim = maximum fix length of universal shaft

① When required tolerance h7

② Tolerance ± 0.1 mm

③ Male and female splined shaft nitrided

⊗ Torque transmission capacity is restricted by state and type of flange connection.

SERIES B

ENGINEERING DATA

TYPE

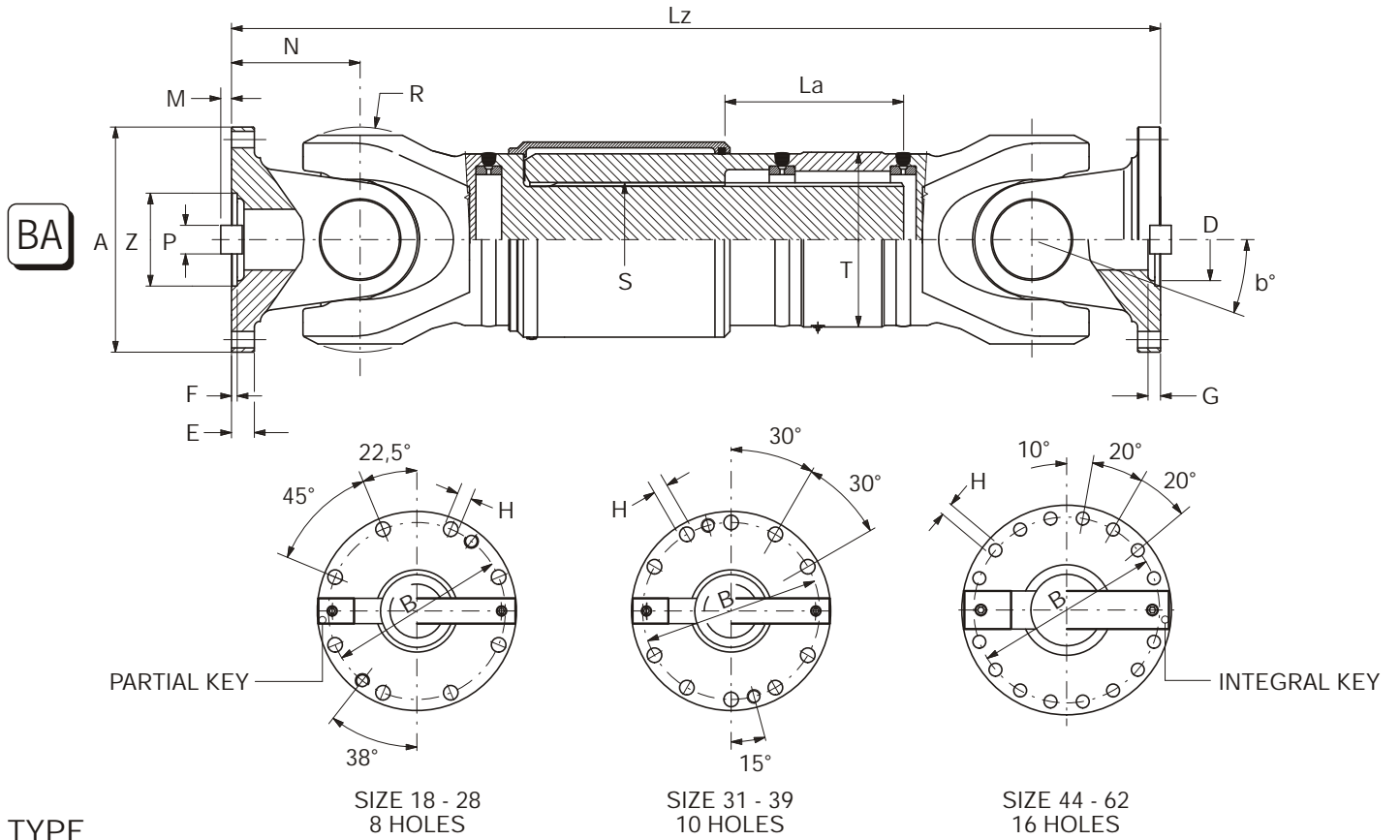

TYPE

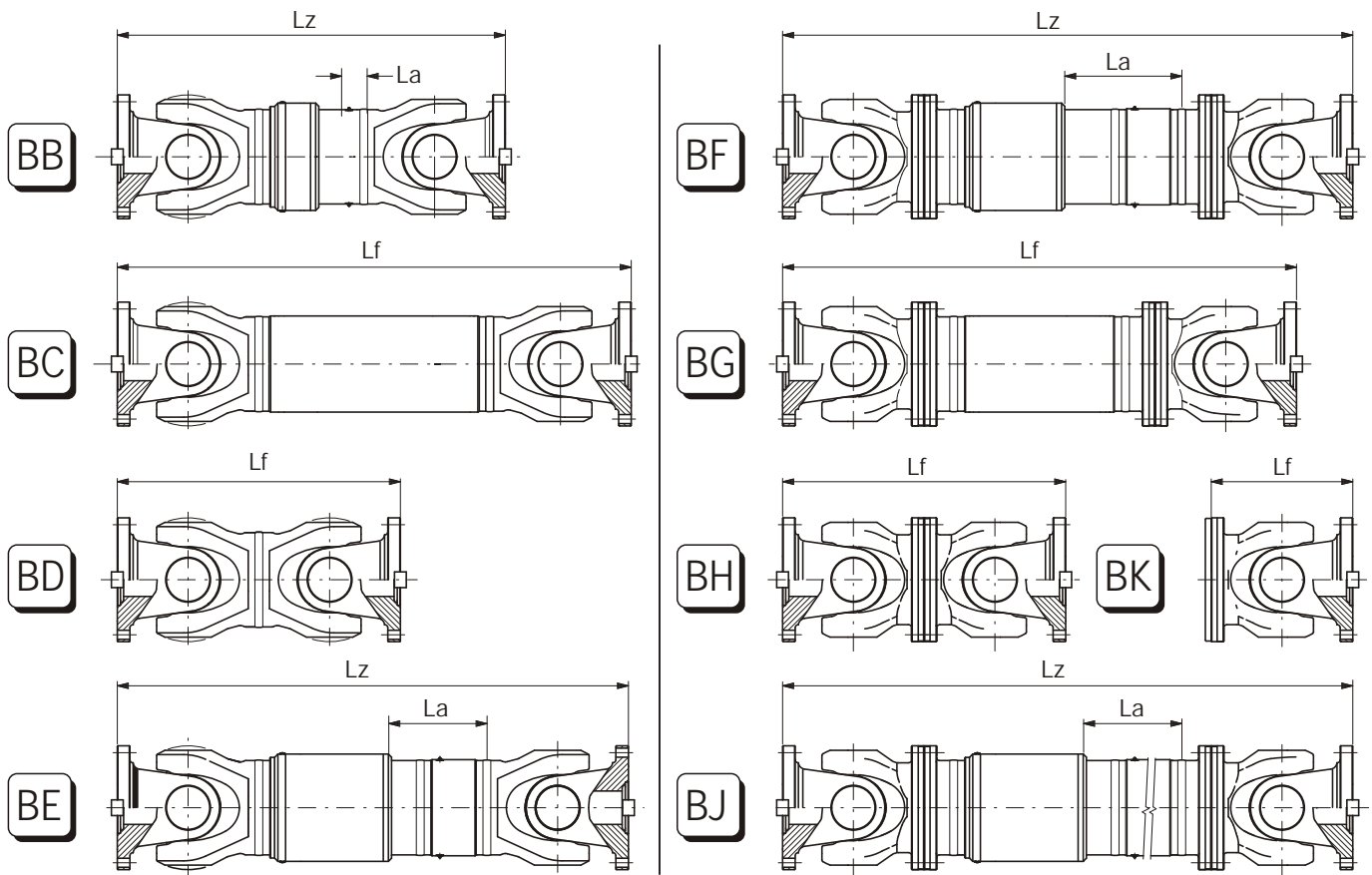

TYPE

BA - Telescopic Shaft, medium length compensation
 BB - Telescopic Shaft, short design
 BC - Fix Length Shaft, tubular design
 BD - Fix Length Shaft, short design
 BE - Telescopic Shaft, long length compensation or high torsional stiffness or special arrangement

BF - Telescopic Shaft, medium length compensation (flange intermediate assembly)
 BG - Fix Length Shaft, flange tubular design
 BH - Fix Length Shaft, flange short design
 BJ - Telescopic Shaft, long length compensation or high torsional stiffness or special arrangement (flange intermediate assembly)
 BK - Flange Joint

TABLE 2

| SIZE | | 18 | 22 | 25 | 28 | 31 | 35 | 39 | 44 | 49 | 55 | 62 | |
|-------------------------------------|---|-------|-------|-------|-------|-------|-------|-------|-------|-------|-------|-------|-------|
| RATING TORQUES | | | | | | | | | | | | | |
| Mk | [kNm] | 28 | 56 | 82 | 119 | 167 | 227 | 302 | 522 | 647 | 1031 | 1350 | |
| MDSch | [kNm] | 19 | 37 | 58 | 85 | 120 | 163 | 224 | 400 | 496 | 800 | 1150 | |
| MdW | [kNm] | 12 | 24 | 37 | 54 | 76 | 106 | 146 | 262 | 321 | 516 | 760 | |
| STANDARD DIMENSIONS | | | | | | | | | | | | | |
| A ① | [mm] | 180 | 225 | 250 | 285 | 315 | 350 | 390 | 440 | 490 | 550 | 620 | |
| b° |  | 15 | 15 | 15 | 15 | 15 | 15 | 15 | 15 | 15 | 15 | 15 | |
| B ② | [mm] | 155.5 | 196 | 218 | 245 | 280 | 310 | 345 | 385 | 425 | 492 | 555 | |
| Z (H7) | [mm] | 90 | 105 | 105 | 125 | 130 | 155 | 170 | 190 | 205 | 250 | 280 | |
| P (h9) | [mm] | 25 | 32 | 40 | 40 | 40 | 50 | 70 | 80 | 90 | 100 | 110 | |
| M | [mm] | 7 | 9 | 12.5 | 15 | 15 | 16 | 18 | 20 | 22.5 | 22.5 | 27.5 | |
| F | [mm] | 5 | 5 | 6 | 7 | 8 | 8 | 8 | 10 | 12 | 12 | 15 | |
| E | [mm] | 17 | 20 | 25 | 27 | 32 | 35 | 40 | 42 | 47 | 50 | 55 | |
| H | [mm] | 17 | 17 | 19 | 21 | 23 | 23 | 25 | 28 | 31 | 31 | 37 | |
| G | [mm] | 15 | 15 | 15 | 16 | 16 | 18 | 20 | 25 | 30 | 30 | 35 | |
| D | [mm] | 80 | 90 | 90 | 110 | 115 | 140 | 155 | 150 | 160 | 190 | 220 | |
| R | [mm] | 180 | 225 | 250 | 285 | 315 | 350 | 390 | 440 | 490 | 550 | 620 | |
| N | [mm] | 110 | 120 | 140 | 160 | 180 | 195 | 210 | 260 | 270 | 305 | 340 | |
| S DIN 5480 ③ | | 90x3 | 110x3 | 130x4 | 140x4 | 180x5 | 190x5 | 210x6 | 220x6 | 250x6 | 280x8 | 320x8 | |
| T | [mm] | 139.7 | 152.4 | 177.8 | 203 | 254 | 298.5 | 323.9 | 355.6 | 368 | 419 | 457.2 | |
| LENGTH / LENGTH COMPENSATION | | | | | | | | | | | | | |
| BA | Lz min | [mm] | 795 | 855 | 985 | 1080 | 1235 | 1350 | 1495 | 1680 | 1760 | 1965 | 2250 |
| | La std | [mm] | 140 | 145 | 150 | 155 | 160 | 170 | 180 | 190 | 200 | 210 | 230 |
| | Lz max | [mm] | 1205 | 1310 | 1485 | 1625 | 1875 | 2080 | 2315 | 2590 | 2810 | 3155 | 3570 |
| BB | La max | [mm] | 550 | 600 | 650 | 700 | 800 | 900 | 1000 | 1100 | 1250 | 1400 | 1550 |
| | Lz min | [mm] | 615 | 685 | 795 | 900 | 1045 | 1175 | 1350 | 1470 | 1550 | 1730 | 1960 |
| | La std | [mm] | 40 | 50 | 50 | 60 | 65 | 70 | 70 | 70 | 70 | 80 | 80 |
| BC | Lf | [mm] | 495 | 535 | 615 | 695 | 780 | 835 | 930 | 1140 | 1205 | 1355 | 1530 |
| | Lf max | [mm] | 1205 | 1310 | 1485 | 1625 | 1875 | 2080 | 2315 | 2590 | 2810 | 3155 | 3550 |
| | Lf lim | [mm] | 3280 | 4000 | 4720 | 5020 | 5740 | 6450 | 7170 | 7890 | 9020 | 10040 | 11300 |
| BD | Lf | [mm] | 440 | 480 | 560 | 640 | 720 | 780 | 840 | 1040 | 1080 | 1220 | 1360 |
| BE | Lz min | [mm] | 985 | 1050 | 1180 | 1295 | 1495 | 1620 | 1775 | 1985 | 2085 | 2310 | 2620 |
| | La std | [mm] | 280 | 290 | 300 | 310 | 320 | 340 | 360 | 380 | 400 | 420 | 460 |
| | Lz max | [mm] | 1505 | 1610 | 1880 | 2085 | 2375 | 2680 | 2915 | 3255 | 3585 | 3990 | 4410 |
| | La max | [mm] | 800 | 850 | 1000 | 1100 | 1200 | 1400 | 1500 | 1650 | 1900 | 2100 | 2250 |
| | Lz lim | [mm] | 3280 | 4000 | 4720 | 5020 | 5740 | 6450 | 7170 | 7890 | 9020 | 10040 | 11300 |
| BF | Lz min | [mm] | 970 | 1000 | 1130 | 1340 | 1585 | 1690 | 1850 | 2075 | 2200 | 2400 | 2750 |
| | La std | [mm] | 140 | 145 | 150 | 155 | 160 | 170 | 180 | 190 | 200 | 210 | 230 |
| | Lz max | [mm] | 1380 | 1455 | 1630 | 1885 | 2225 | 2420 | 2670 | 2985 | 3250 | 3590 | 4070 |
| | La max | [mm] | 550 | 600 | 650 | 700 | 800 | 900 | 1000 | 1100 | 1250 | 1400 | 1550 |
| BG | Lf | [mm] | 715 | 730 | 800 | 950 | 1140 | 1225 | 1350 | 1660 | 1745 | 1800 | 2050 |
| | Lf max | [mm] | 1380 | 1455 | 1630 | 1885 | 2225 | 2420 | 2670 | 2985 | 3250 | 3590 | 4050 |
| | Lf lim | [mm] | 3280 | 4000 | 4720 | 5020 | 5740 | 6450 | 7170 | 7890 | 9020 | 10040 | 11300 |
| BH | Lf | [mm] | 440 | 480 | 560 | 640 | 720 | 780 | 840 | 1040 | 1080 | 1220 | 1360 |
| BJ | Lz min | [mm] | 1160 | 1195 | 1325 | 1555 | 1845 | 1960 | 2130 | 2380 | 2525 | 2745 | 3120 |
| | La std | [mm] | 280 | 290 | 300 | 310 | 320 | 340 | 360 | 380 | 400 | 420 | 460 |
| | Lz max | [mm] | 1680 | 1755 | 2025 | 2345 | 2725 | 3020 | 3270 | 3650 | 4025 | 4425 | 4910 |
| | La max | [mm] | 800 | 850 | 1000 | 1100 | 1200 | 1400 | 1500 | 1650 | 1900 | 2100 | 2250 |
| | Lz lim | [mm] | 3280 | 4000 | 4720 | 5020 | 5740 | 6450 | 7170 | 7890 | 9020 | 10040 | 11300 |
| BK | Lf | [mm] | 220 | 240 | 280 | 320 | 360 | 390 | 420 | 520 | 540 | 610 | 680 |

Lz min = shortest length corresponding to La std
 La std = standard length compensation
 Lz max = shortest length corresponding to La max
 La max = maximum length compensation
 Lz lim = maximum length of universal shaft
 When Lz ≠ Lz min, then Lz = Lz min + (La - La std)

Lf = fix length
 Lf min = minimum fix length
 Lf max = maximum fix length with standard tube
 Lf lim = maximum fix length of universal shaft
 Lz max, Lz lim, Lf max, Lf lim valid if max allowable speed or torsional stiffness do not create any problem.

① When required tolerance h7
 ② Tolerance ± 0.1 mm
 ③ Male and female splined shaft nitrided.

SERIES C

ENGINEERING DATA

TYPE

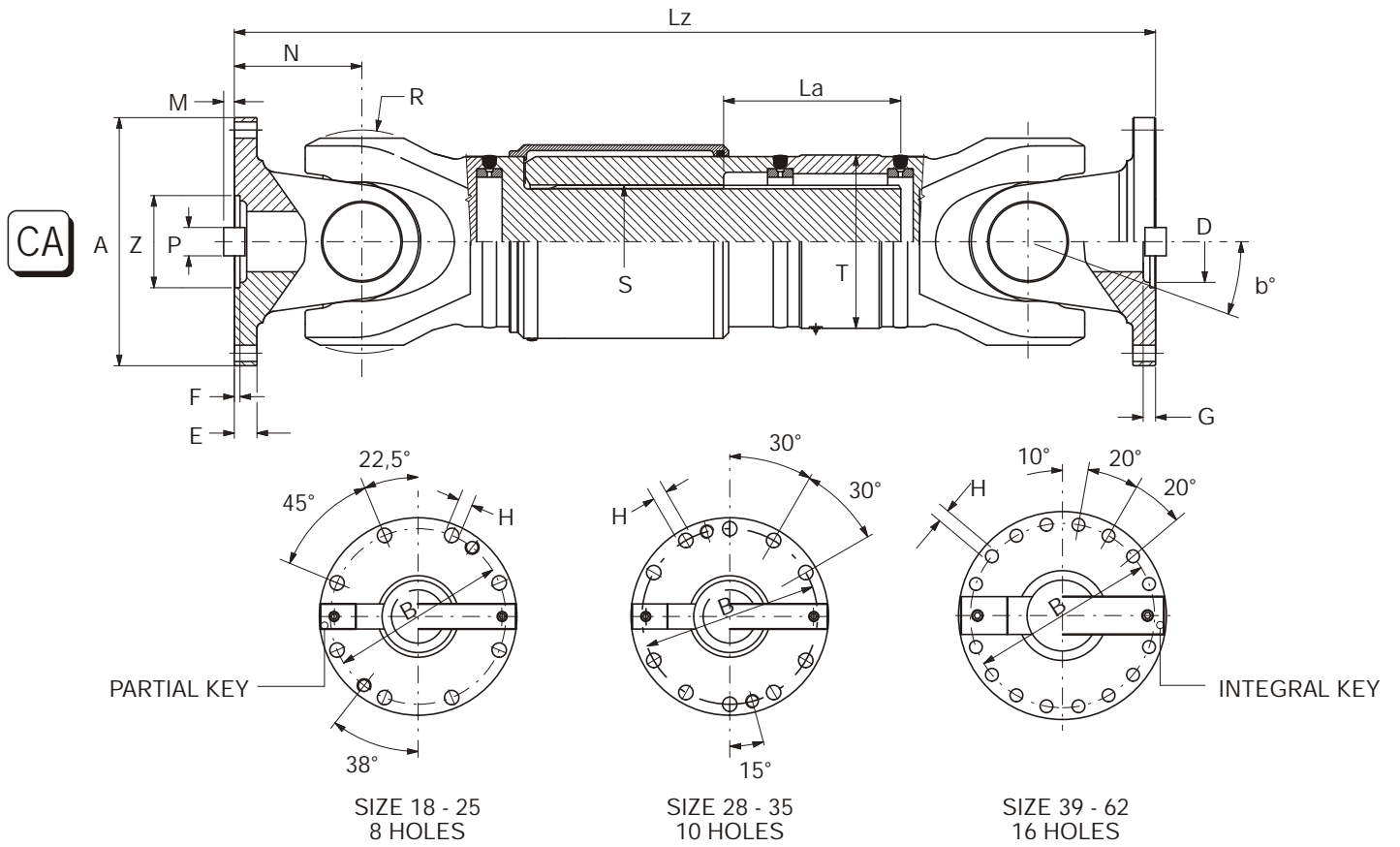

TYPE

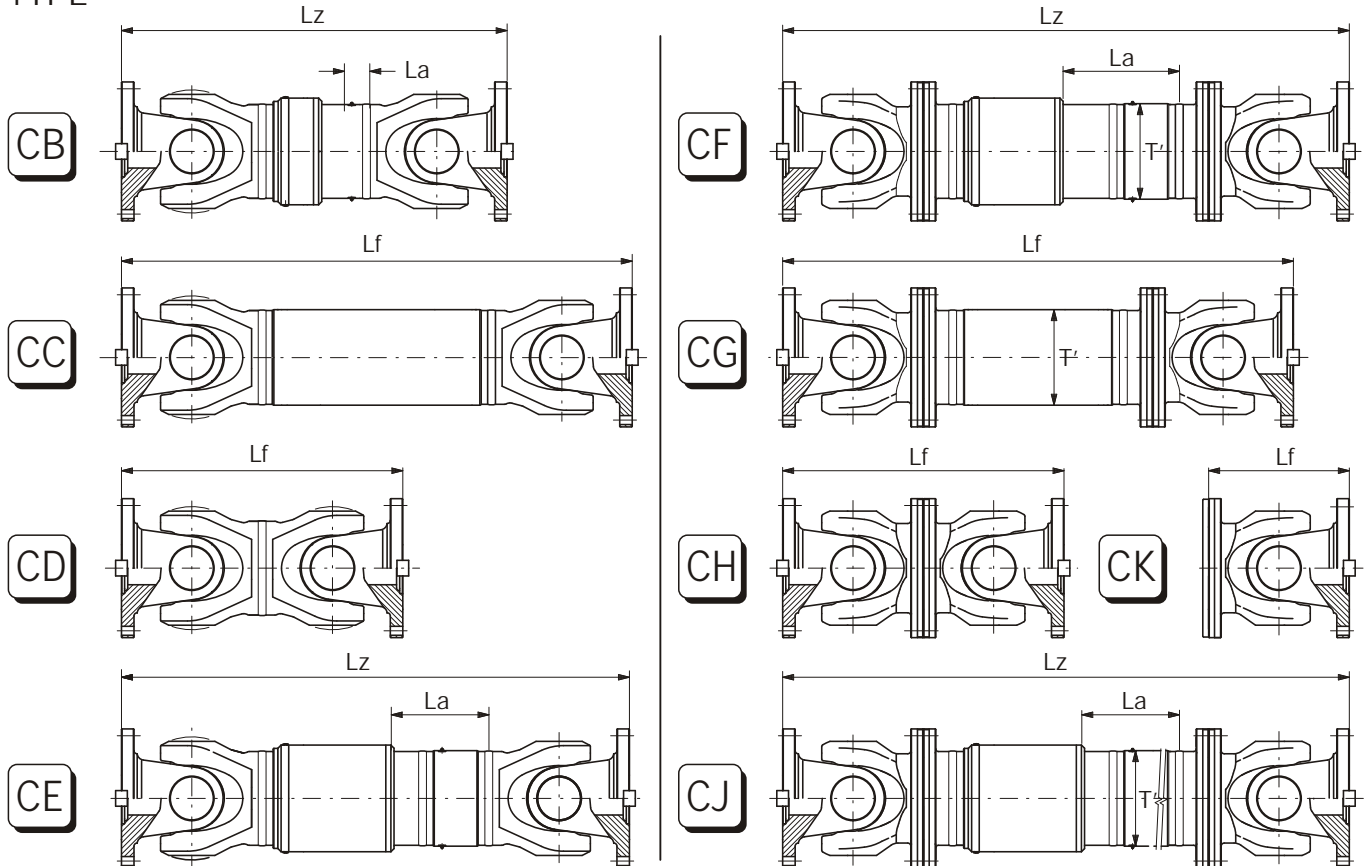

TYPE

CA - Telescopic Shaft, medium length compensation
 CB - Telescopic Shaft, short design
 CC - Fix Length Shaft, tubular design
 CD - Fix Length Shaft, short design
 CE - Telescopic Shaft, long length compensation or high torsional stiffness or special arrangement

CF - Telescopic Shaft, medium length compensation (flange intermediate assembly)
 CG - Fix Length Shaft, flange tubular design
 CH - Fix Length Shaft, flange short design
 CJ - Telescopic Shaft, long length compensation or high torsional stiffness or special arrangement (flange intermediate assembly)
 CK - Flange Joint

TABLE 3

| SIZE | | 18 | 22 | 25 | 28 | 31 | 35 | 39 | 44 | 49 | 55 | 62 | |
|------------------------------|---|-------|-------|-------|-------|-------|-------|-------|-------|-------|-------|-------|-------|
| RATING TORQUES | | | | | | | | | | | | | |
| Mk | [kNm] | 28 | 56 | 82 | 119 | 167 | 227 | 302 | 522 | 647 | 1031 | 1350 | |
| MDSch | [kNm] | 19 | 37 | 58 | 85 | 120 | 163 | 224 | 400 | 496 | 800 | 1150 | |
| MDw | [kNm] | 12 | 24 | 37 | 54 | 76 | 106 | 146 | 262 | 321 | 516 | 760 | |
| STANDARD DIMENSIONS | | | | | | | | | | | | | |
| A ① | [mm] | 225 | 250 | 285 | 315 | 350 | 390 | 440 | 490 | 550 | 600 | 680 | |
| b° |  | 15 | 15 | 15 | 15 | 15 | 15 | 15 | 15 | 15 | 15 | 15 | |
| B ② | [mm] | 196 | 218 | 245 | 280 | 310 | 345 | 385 | 425 | 492 | 544 | 615 | |
| Z (H7) | [mm] | 140 | 140 | 175 | 175 | 220 | 250 | 280 | 320 | 380 | 450 | 450 | |
| P (h9) | [mm] | 32 | 40 | 40 | 40 | 50 | 70 | 80 | 90 | 100 | 100 | 110 | |
| M | [mm] | 7 | 9 | 12.5 | 15 | 15 | 16 | 18 | 20 | 22.5 | 22.5 | 27.5 | |
| F | [mm] | 5 | 6 | 7 | 7 | 8 | 8 | 8 | 10 | 12 | 15 | 15 | |
| E | [mm] | 17 | 20 | 25 | 27 | 32 | 35 | 40 | 42 | 47 | 50 | 55 | |
| H | [mm] | 17 | 19 | 21 | 23 | 23 | 25 | 28 | 31 | 31 | 34 | 37 | |
| G | [mm] | 15 | 15 | 15 | 16 | 16 | 18 | 20 | 25 | 30 | 30 | 35 | |
| D | [mm] | 80 | 90 | 90 | 110 | 115 | 140 | 155 | 150 | 160 | 190 | 220 | |
| R | [mm] | 180 | 225 | 250 | 285 | 315 | 350 | 390 | 440 | 490 | 550 | 620 | |
| N | [mm] | 110 | 120 | 140 | 160 | 180 | 195 | 210 | 260 | 270 | 305 | 340 | |
| S DIN 5480 ③ | | 90x3 | 110x3 | 130x4 | 140x4 | 180x5 | 190x5 | 210x6 | 220x6 | 250x6 | 280x8 | 320x8 | |
| T | [mm] | 139.7 | 152.4 | 177.8 | 203 | 254 | 298.5 | 323.9 | 355.6 | 368 | 419 | 457.2 | |
| T' | [mm] | 168.3 | 177.8 | 203 | 244.5 | 273 | 323.9 | 355.6 | 368 | 419 | 457.2 | 508 | |
| LENGTH / LENGTH COMPENSATION | | | | | | | | | | | | | |
| CA | Lz min | [mm] | 795 | 855 | 985 | 1080 | 1235 | 1350 | 1495 | 1680 | 1760 | 1965 | 2250 |
| | La std | [mm] | 140 | 145 | 150 | 155 | 160 | 170 | 180 | 190 | 200 | 210 | 230 |
| | Lz max | [mm] | 1205 | 1310 | 1485 | 1625 | 1875 | 2080 | 2315 | 2590 | 2810 | 3155 | 3570 |
| CB | La max | [mm] | 550 | 600 | 650 | 700 | 800 | 900 | 1000 | 1100 | 1250 | 1400 | 1550 |
| | Lz min | [mm] | 615 | 685 | 795 | 900 | 1045 | 1175 | 1350 | 1470 | 1550 | 1730 | 1960 |
| | La std | [mm] | 40 | 50 | 50 | 60 | 65 | 70 | 70 | 70 | 70 | 80 | 80 |
| CC | Lf | [mm] | 495 | 535 | 615 | 695 | 780 | 835 | 930 | 1140 | 1205 | 1355 | 1530 |
| | Lf max | [mm] | 1205 | 1310 | 1485 | 1625 | 1875 | 2080 | 2315 | 2590 | 2810 | 3155 | 3550 |
| | Lf lim | [mm] | 3280 | 4000 | 4720 | 5020 | 5740 | 6450 | 7170 | 7890 | 9020 | 10040 | 11300 |
| CD | Lf | [mm] | 440 | 480 | 560 | 640 | 720 | 780 | 840 | 1040 | 1080 | 1220 | 1360 |
| | Lz min | [mm] | 985 | 1050 | 1180 | 1295 | 1495 | 1620 | 1775 | 1985 | 2085 | 2310 | 2620 |
| | La std | [mm] | 280 | 290 | 300 | 310 | 320 | 340 | 360 | 380 | 400 | 420 | 460 |
| CE | Lz max | [mm] | 1505 | 1610 | 1880 | 2085 | 2375 | 2680 | 2915 | 3255 | 3585 | 3990 | 4410 |
| | La max | [mm] | 800 | 850 | 1000 | 1100 | 1200 | 1400 | 1500 | 1650 | 1900 | 2100 | 2250 |
| | Lz lim | [mm] | 3280 | 4000 | 4720 | 5020 | 5740 | 6450 | 7170 | 7890 | 9020 | 10040 | 11300 |
| CF | Lz min | [mm] | 970 | 1000 | 1130 | 1340 | 1585 | 1690 | 1850 | 2075 | 2200 | 2400 | 2750 |
| | La std | [mm] | 140 | 145 | 150 | 155 | 160 | 170 | 180 | 190 | 200 | 210 | 230 |
| | Lz max | [mm] | 1380 | 1455 | 1630 | 1885 | 2225 | 2420 | 2670 | 2985 | 3250 | 3590 | 4070 |
| CG | La max | [mm] | 550 | 600 | 650 | 700 | 800 | 900 | 1000 | 1100 | 1250 | 1400 | 1550 |
| | Lf | [mm] | 715 | 730 | 800 | 950 | 1140 | 1225 | 1350 | 1660 | 1745 | 1800 | 2050 |
| | Lf max | [mm] | 1380 | 1455 | 1630 | 1885 | 2225 | 2420 | 2670 | 2985 | 3250 | 3590 | 4050 |
| CH | Lf lim | [mm] | 3280 | 4000 | 4720 | 5020 | 5740 | 6450 | 7170 | 7890 | 9020 | 10040 | 11300 |
| | Lf | [mm] | 440 | 480 | 560 | 640 | 720 | 780 | 840 | 1040 | 1080 | 1220 | 1360 |
| | Lz min | [mm] | 1160 | 1195 | 1325 | 1555 | 1845 | 1960 | 2130 | 2380 | 2525 | 2745 | 3120 |
| CJ | La std | [mm] | 280 | 290 | 300 | 310 | 320 | 340 | 360 | 380 | 400 | 420 | 460 |
| | Lz max | [mm] | 1680 | 1755 | 2025 | 2345 | 2725 | 3020 | 3270 | 3650 | 4025 | 4425 | 4910 |
| | La max | [mm] | 800 | 850 | 1000 | 1100 | 1200 | 1400 | 1500 | 1650 | 1900 | 2100 | 2250 |
| CK | Lz lim | [mm] | 3280 | 4000 | 4720 | 5020 | 5740 | 6450 | 7170 | 7890 | 9020 | 10040 | 11300 |
| | Lf | [mm] | 220 | 240 | 280 | 320 | 360 | 390 | 420 | 520 | 540 | 610 | 680 |

Lz min = shortest length corresponding to La std
 La std = standard length compensation
 Lz max = shortest length corresponding to La max
 La max = maximum length compensation
 Lz lim = maximum length of universal shaft
 When Lz ≠ Lz min, then Lz = Lz min + (La - La std)

Lf = fix length
 Lf min = minimum fix length
 Lf max = maximum fix length with standard tube
 Lf lim = maximum fix length of universal shaft
 Lz max, Lz lim, Lf max, Lf lim valid if max allowable speed or torsional stiffness do not create any problem.

① When required tolerance h7
 ② Tolerance ± 0.1 mm
 ③ Male and female splined shaft nitrided.

SERIES S

ENGINEERING DATA

TYPE

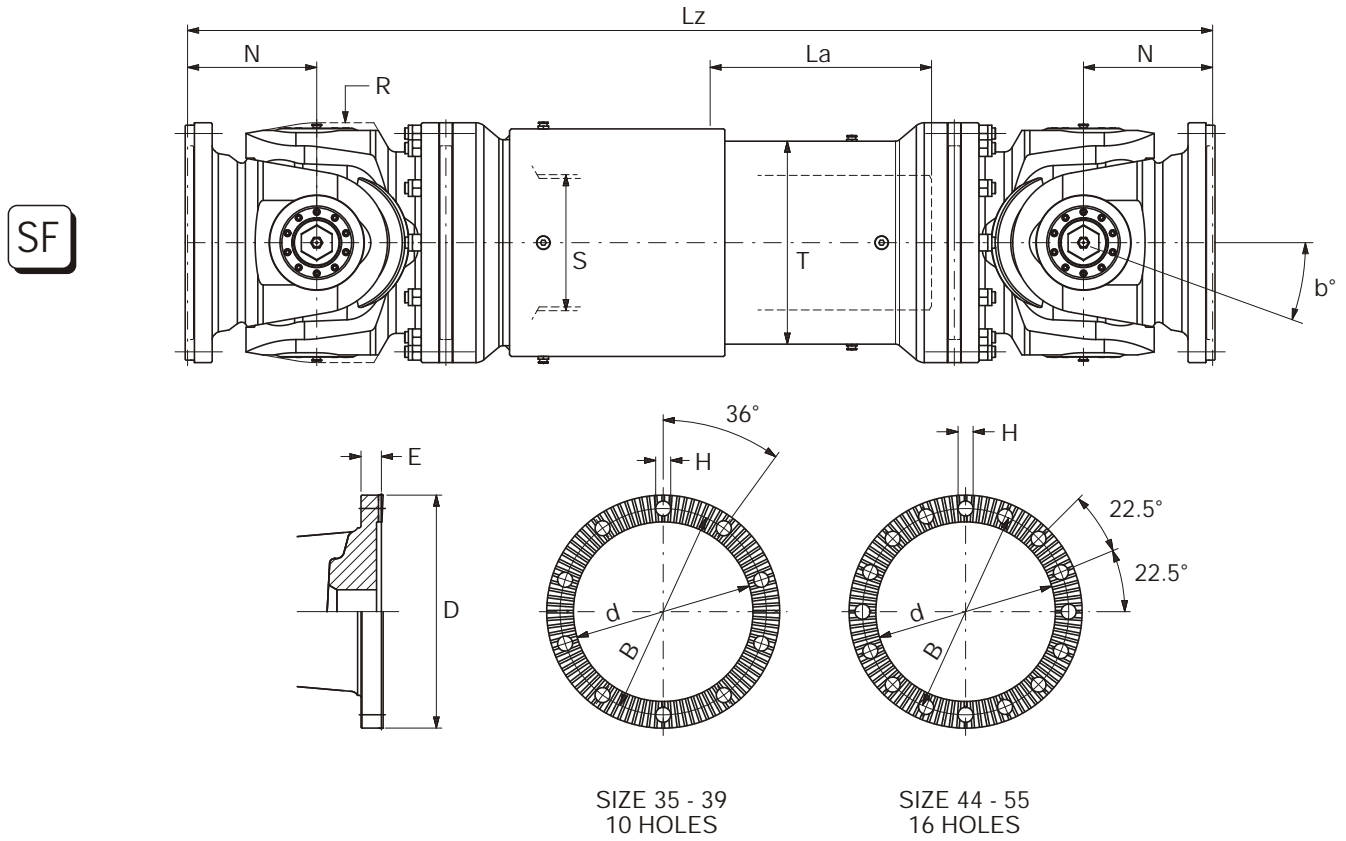

TYPE

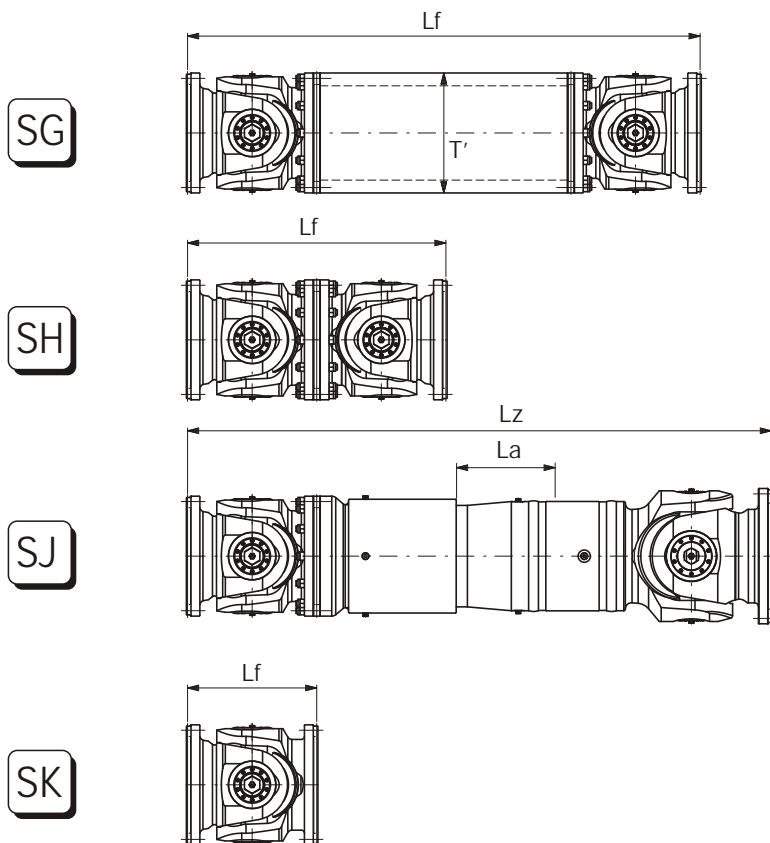

ENGINEERING DATA
SERIES S
TYPE

- SF - Telescopic Shaft, medium length compensation
(flange intermediate assembly)
- SG - Fix Length Shaft, flange tubular design
- SH - Fix Length Shaft, flange short design
- SJ - Telescopic Shaft, medium length compensation
series S flange joint roll side
series B weld joint pinion side, bigger rotation
- SK - Flange Joint

TABLE 4

| SIZE | | 35 | 39 | 44 | 49 | 55 | |
|-------------------------------------|---|-------|-------|-------|-------|-------|-------|
| RATING TORQUES | | | | | | | |
| Mk | [kNm] | 264 | 389 | 560 | 743 | 1115 | |
| MDSch | [kNm] | 204 | 300 | 431 | 572 | 859 | |
| Mdw | [kNm] | 143 | 211 | 302 | 401 | 602 | |
| STANDARD DIMENSIONS | | | | | | | |
| D | [mm] | 350 | 390 | 440 | 490 | 550 | |
| d | [mm] | 280 | 315 | 340 | 380 | 440 | |
| B ① | [mm] | 315 | 350 | 400 | 450 | 510 | |
| H | [mm] | 19 | 21 | 21 | 23 | 23 | |
| E | [mm] | 35 | 40 | 42 | 47 | 50 | |
| z ② | | 72 | 72 | 96 | 96 | 96 | |
| b |  | 10 | 10 | 10 | 10 | 10 | |
| R | [mm] | 350 | 390 | 440 | 490 | 550 | |
| N | [mm] | 195 | 210 | 260 | 270 | 305 | |
| T | [mm] | 323.9 | 355.6 | 368 | 419 | 457.2 | |
| S DIN 5480 ③ | | 210x6 | 220x6 | 250x6 | 280x8 | 320x8 | |
| T' | [mm] | 350 | 390 | 440 | 490 | 550 | |
| LENGTH / LENGTH COMPENSATION | | | | | | | |
| SF | Lz min | [mm] | 1690 | 1850 | 2075 | 2200 | 2400 |
| | La std | [mm] | 170 | 180 | 190 | 200 | 210 |
| | Lz max | [mm] | 2420 | 2670 | 2985 | 3250 | 3590 |
| SG | La max | [mm] | 900 | 1000 | 1100 | 1250 | 1400 |
| | Lf | [mm] | 1225 | 1350 | 1660 | 1745 | 1800 |
| SH | Lf lim | [mm] | 6450 | 7170 | 7890 | 9020 | 10040 |
| | Lf | [mm] | 780 | 840 | 1040 | 1080 | 1220 |
| SJ | Lz min | [mm] | 1720 | 1950 | 2095 | 2270 | 2470 |
| | La std | [mm] | 170 | 180 | 190 | 200 | 210 |
| | Lz max | [mm] | 2450 | 2770 | 3005 | 3320 | 3660 |
| | La max | [mm] | 900 | 1000 | 1100 | 1250 | 1400 |
| SK | Lf | [mm] | 390 | 420 | 520 | 540 | 610 |

Lz min = shortest length corresponding to La std
 La std = standard length compensation
 Lz max = shortest length corresponding to La max
 La max = maximum length compensation
 When Lz ≠ Lz min, then Lz = Lz min + (La - La std)

Lf = fix length
 Lf min = minimum fix length
 Lf lim = maximum fix length of universal shaft
 Lz max and Lf lim valid if max allowable
 speed or torsional stiffness do not create any problem.

- ① Tolerance ± 0.1 mm
- ② Number of teeth
- ③ Male and female splined shaft
nitrided

SERIES D - SERIES G

ENGINEERING DATA

TYPE

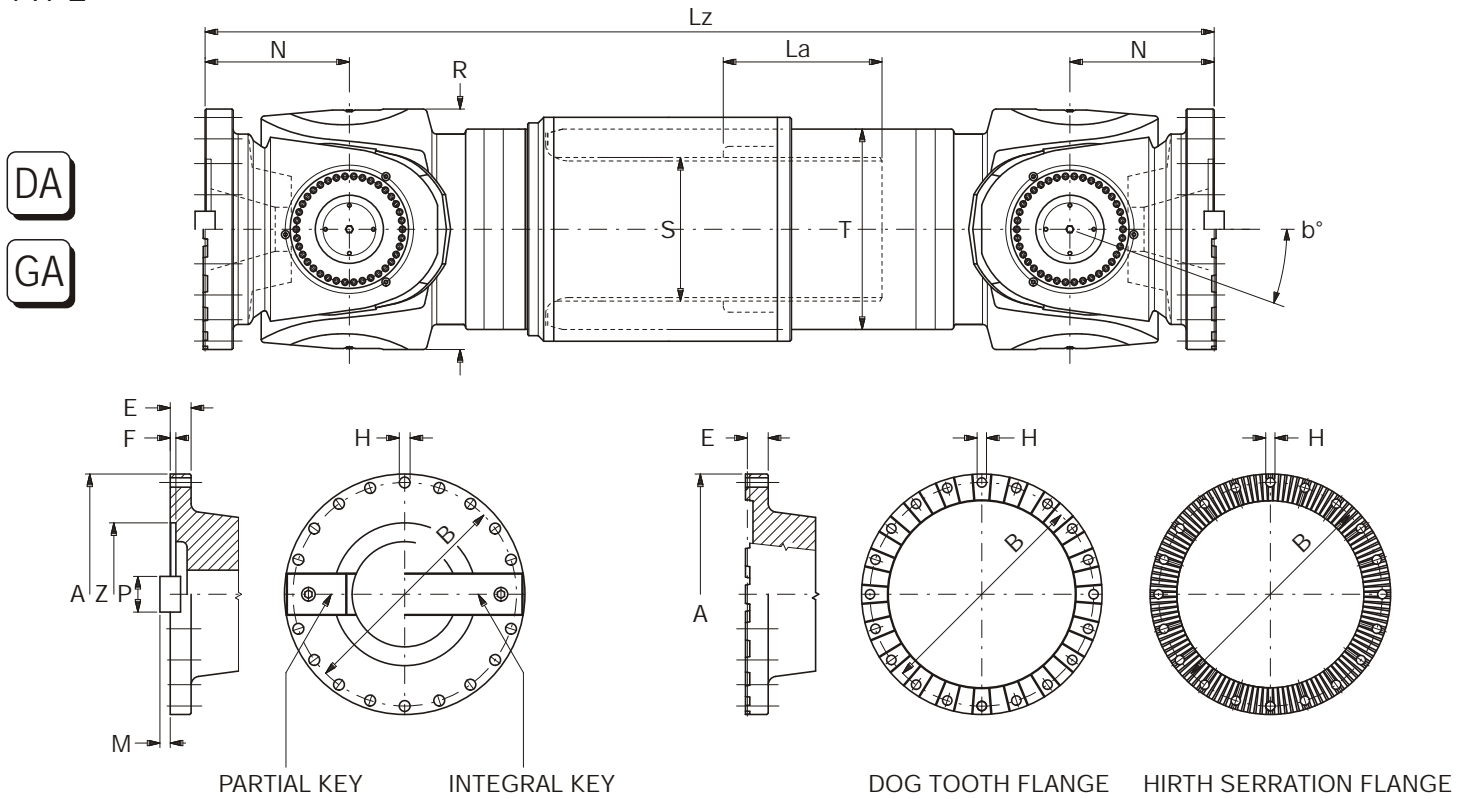

TYPE

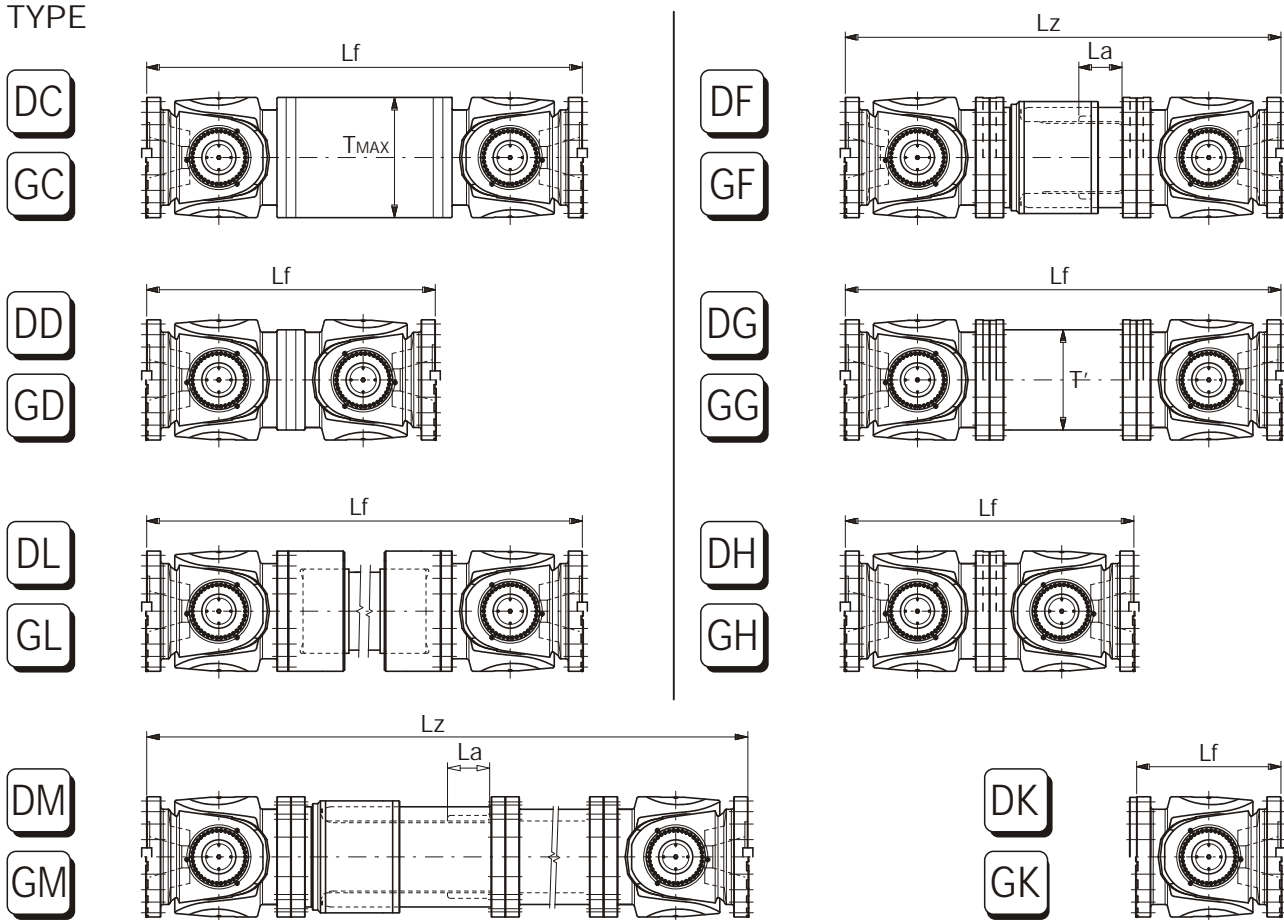

ENGINEERING DATA
SERIES D - SERIES G
TYPE WITH STANDARD FLANGES

DA - Telescopic Shaft
 DC - Fix Length Shaft, tubular design
 DD - Fix Length Shaft, short design
 DL - Fix Length Shaft, intermediate shaft design
 DM - Telescopic Shaft, intermediate tubular design
 DF - Telescopic Shaft, flange intermediate design
 DG - Fix Length Shaft, flange tubular design
 DH - Fix Length Shaft, flange short design
 DK - Flange Joint

TYPE WITH LARGER FLANGES

GA - Telescopic Shaft
 GC - Fix Length Shaft, tubular design
 GD - Fix Length Shaft, short design
 GL - Fix Length Shaft, intermediate shaft design
 GM - Telescopic Shaft, intermediate tubular design
 GF - Telescopic Shaft, flange intermediate design
 GG - Fix Length Shaft, flange tubular design
 GH - Fix Length Shaft, flange short design
 GK - Flange Joint

TABLE 5

| SIZE | | 60 | 65 | 70 | 75 | 80 | 85 | 90 | 95 | 100 | 105 | 110 | 115 | 120 | 125 | | |
|-------------------------------------|---|---------|---------|---------|---------|---------|---------|---------|---------|---------|---------|---------|---------|---------|---------|------|------|
| RATING TORQUES | | | | | | | | | | | | | | | | | |
| Mk | [kNm] | 1070 | 1310 | 1650 | 2040 | 2520 | 3010 | 3490 | 4170 | 4850 | 5630 | 6400 | 7370 | 8370 | 9470 | | |
| MDSch | [kNm] | 960 | 1180 | 1480 | 1830 | 2250 | 2740 | 3170 | 3800 | 4360 | 5070 | 5770 | 6610 | 7510 | 8490 | | |
| M _{DW} | [kNm] | 660 | 815 | 1020 | 1260 | 1550 | 1890 | 2185 | 2620 | 3010 | 3495 | 3980 | 4560 | 5180 | 5860 | | |
| STANDARD FLANGES SERIES D | | | | | | | | | | | | | | | | | |
| A | [mm] | 600 | 650 | 700 | 750 | 800 | 850 | 900 | 950 | 1000 | 1050 | 1100 | 1150 | 1200 | 1250 | | |
| b° |  | 10 ÷ 15 | 10 ÷ 15 | 10 ÷ 15 | 10 ÷ 15 | 10 ÷ 15 | 10 ÷ 15 | 10 ÷ 15 | 10 ÷ 15 | 10 ÷ 15 | 10 ÷ 15 | 10 ÷ 15 | 10 ÷ 15 | 10 ÷ 15 | 10 ÷ 15 | | |
| B [⊙] | [mm] | 544 | 595 | 645 | 690 | 740 | 775 | 825 | 875 | 915 | 965 | 1015 | 1050 | 1100 | 1140 | | |
| Z (H7) | [mm] | 380 | 400 | 420 | 450 | 470 | 500 | 530 | 560 | 590 | 620 | 650 | 680 | 710 | 750 | | |
| P (h9) | [mm] | 100 | 120 | 120 | 130 | 140 | 160 | 160 | 160 | 180 | 180 | 195 | 220 | 230 | 240 | | |
| M | [mm] | 27.5 | 30 | 30 | 32.5 | 35 | 37.5 | 40 | 42.5 | 45 | 47.5 | 50 | 52.5 | 55 | 57.5 | | |
| F | [mm] | 15 | 15 | 15 | 15 | 18 | 18 | 20 | 20 | 20 | 22 | 22 | 25 | 25 | 27.5 | | |
| E | [mm] | 70 | 75 | 80 | 85 | 90 | 95 | 100 | 105 | 110 | 115 | 120 | 125 | 130 | 135 | | |
| H | [mm] | 34 | 28 | 28 | 31 | 31 | 37 | 37 | 37 | 43 | 43 | 43 | 49 | 49 | 53 | | |
| i [⊙] | | 16 | 30 | 34 | 30 | 34 | 30 | 32 | 34 | 32 | 34 | 32 | 30 | 32 | 30 | | |
| R | [mm] | 600 | 650 | 700 | 750 | 800 | 850 | 900 | 950 | 1000 | 1050 | 1100 | 1150 | 1200 | 1250 | | |
| N | [mm] | 360 | 390 | 420 | 450 | 480 | 510 | 540 | 570 | 600 | 630 | 660 | 690 | 720 | 750 | | |
| S | | 360x8 | 400x8 | 440x10 | 480x10 | 530x12 | 570x12 | 610x14 | 650x14 | 690x16 | 740x16 | 780x18 | 830x18 | 880x20 | 1030x20 | | |
| T | [mm] | 508 | 558.8 | 609.6 | 660.4 | 711.2 | 760 | 810 | 860 | 910 | 960 | 1010 | 1050 | 1100 | 1150 | | |
| T' | [mm] | 508 | 558.8 | 609.6 | 640 | 690 | 715 | 765 | 815 | 845 | 895 | 945 | 970 | 1020 | 1070 | | |
| T _{MAX} | [mm] | 600 | 650 | 700 | 750 | 800 | 850 | 900 | 950 | 1000 | 1050 | 1100 | 1150 | 1200 | 1250 | | |
| LARGER FLANGES SERIES G | | | | | | | | | | | | | | | | | |
| A | [mm] | 650 | 700 | 750 | 800 | 850 | 900 | 950 | 1000 | 1050 | 1100 | 1150 | 1200 | 1250 | 1300 | | |
| B [⊙] | [mm] | 595 | 645 | 690 | 740 | 775 | 825 | 875 | 915 | 965 | 1015 | 1050 | 1100 | 1150 | 1190 | | |
| Z (H7) | [mm] | 400 | 420 | 450 | 470 | 500 | 530 | 560 | 590 | 620 | 650 | 680 | 710 | 750 | 790 | | |
| P (h9) | [mm] | 120 | 120 | 130 | 140 | 160 | 160 | 160 | 180 | 180 | 195 | 220 | 230 | 240 | 250 | | |
| M | [mm] | 30 | 30 | 32.5 | 35 | 37.5 | 40 | 42.5 | 45 | 47.5 | 50 | 52.5 | 55 | 57.5 | 60 | | |
| F | [mm] | 15 | 15 | 15 | 18 | 18 | 20 | 20 | 20 | 22 | 22 | 25 | 25 | 27.5 | 27.5 | | |
| E | [mm] | 75 | 80 | 85 | 90 | 95 | 100 | 105 | 110 | 115 | 120 | 125 | 130 | 140 | 150 | | |
| H | [mm] | 28 | 28 | 31 | 31 | 37 | 37 | 37 | 43 | 43 | 43 | 49 | 49 | 49 | 53 | | |
| i [⊙] | | 30 | 34 | 30 | 34 | 30 | 32 | 34 | 32 | 34 | 32 | 30 | 32 | 32 | 32 | | |
| LENGTH / LENGTH COMPENSATION | | | | | | | | | | | | | | | | | |
| DA | GA | Lz | [mm] | 2420 | 2610 | 2800 | 2950 | 3140 | 3290 | 3480 | 3620 | 3810 | 3960 | 4130 | 4270 | 4450 | 4570 |
| | | La | [mm] | 300 | 300 | 350 | 350 | 400 | 400 | 450 | 450 | 500 | 500 | 550 | 550 | 600 | 600 |
| DC | GC | Lf | [mm] | 1640 | 1780 | 1910 | 2050 | 2190 | 2320 | 2460 | 2600 | 2730 | 2870 | 3000 | 3150 | 3300 | 3450 |
| | | Lf | [mm] | 1440 | 1560 | 1680 | 1800 | 1920 | 2040 | 2160 | 2280 | 2400 | 2520 | 2640 | 2760 | 2880 | 3000 |
| DF | GF | Lz | [mm] | 2630 | 2840 | 3040 | 3200 | 3410 | 3570 | 3780 | 3940 | 4140 | 4310 | 4490 | 4650 | 4850 | 4990 |
| | | La | [mm] | 300 | 300 | 350 | 350 | 400 | 400 | 450 | 450 | 500 | 500 | 550 | 550 | 600 | 600 |
| DG | GG | Lf | [mm] | 1850 | 2010 | 2150 | 2300 | 2460 | 2600 | 2760 | 2920 | 3060 | 3220 | 3360 | 3530 | 3700 | 3870 |
| | | Lf | [mm] | 1440 | 1560 | 1680 | 1800 | 1920 | 2040 | 2160 | 2280 | 2400 | 2520 | 2640 | 2760 | 2880 | 3000 |
| DK | GK | Lf | [mm] | 720 | 780 | 840 | 900 | 960 | 1020 | 1080 | 1140 | 1200 | 1260 | 1320 | 1380 | 1440 | 1500 |
| | | Lf | [mm] | 4640 | 5030 | 5420 | 5800 | 6190 | 6580 | 6960 | 7350 | 7740 | 8120 | 8500 | 8900 | 9300 | 9700 |
| DL | GL | Lz | [mm] | 3040 | 3290 | 3520 | 3710 | 3950 | 4140 | 4380 | 4580 | 4810 | 5010 | 5220 | 5410 | 5620 | 5770 |
| | | La | [mm] | 300 | 300 | 350 | 350 | 400 | 400 | 450 | 450 | 500 | 500 | 550 | 550 | 600 | 600 |

Lz = Shortest length
 La = Length compensation
 Lf = Shortest fix length

⊙ Tolerance ± 0.1 mm
 ⊙ i = number of holes

Length dimension (Lz and La) for reference only. Series D and G central body designed on request.
 Please contact MAINA for selection of series D and G universal shafts.

SERIES F - SERIES J

ENGINEERING DATA

TYPE

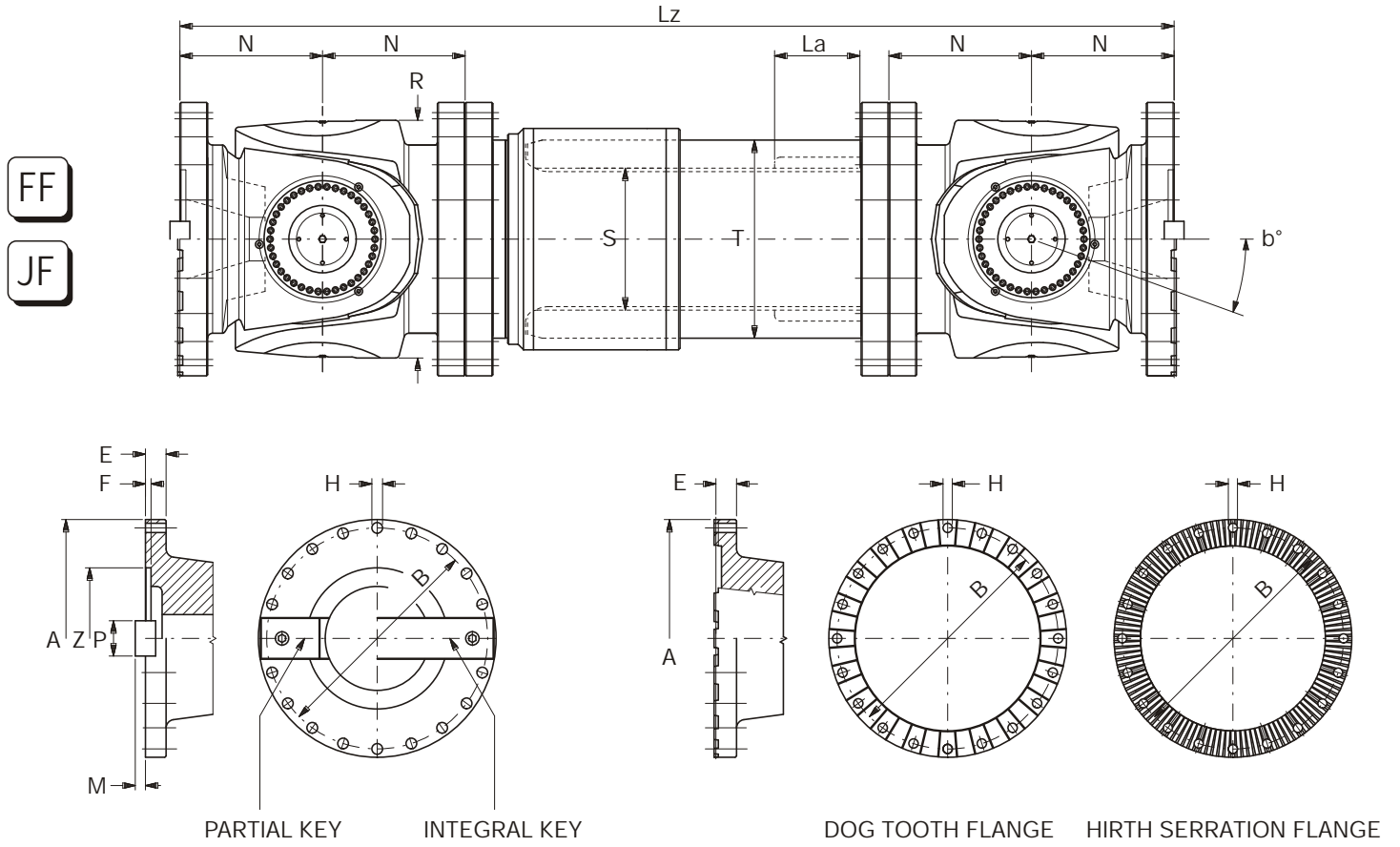

TYPE

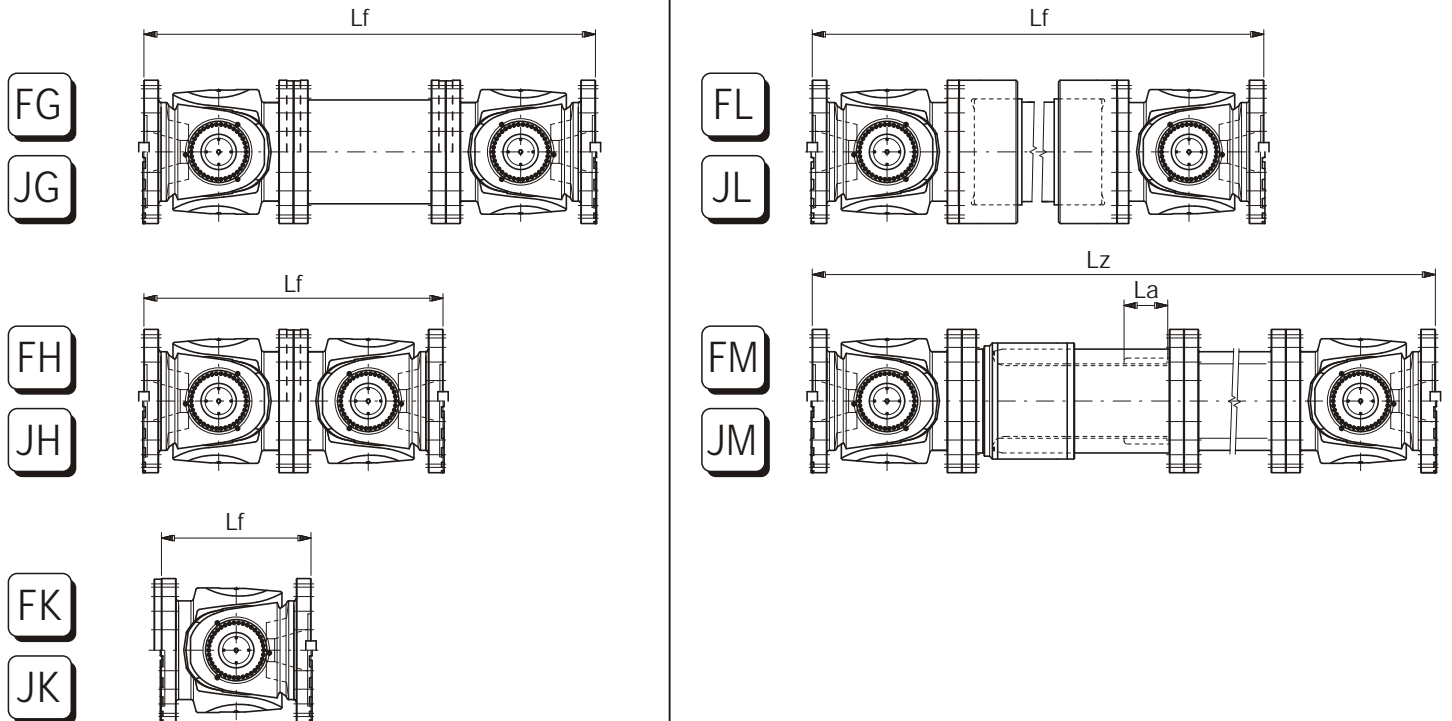

ENGINEERING DATA
SERIES F - SERIES J
TYPE WITH STANDARD FLANGES

FF - Telescopic Shaft, flange intermediate design
 FG - Fix Length Shaft, flange tubular design
 FH - Fix Length Shaft, flange short design
 FK - Flange Joint
 FL - Fix Length Shaft, intermediate shaft design
 FM - Telescopic Shaft, intermediate tubular design

TYPE WITH LARGER FLANGES

JF - Telescopic Shaft, flange intermediate design
 JG - Fix Length Shaft, flange tubular design
 JH - Fix Length Shaft, flange short design
 JK - Flange Joint
 JL - Fix Length Shaft, intermediate shaft design
 JM - Telescopic Shaft, intermediate tubular design

TABLE 6

| SIZE | | 60 | 65 | 70 | 75 | 80 | 85 | 90 | 95 | 100 | 105 | 110 | 115 | 120 | 125 | | |
|-------------------------------------|---|--------|--------|--------|--------|--------|--------|--------|--------|--------|--------|--------|--------|---------|---------|------|------|
| RATING TORQUES | | | | | | | | | | | | | | | | | |
| Mk | [kNm] | 1410 | 1750 | 2230 | 2720 | 3300 | 3980 | 4750 | 5530 | 6500 | 7470 | 8630 | 9900 | 11200 | 12665 | | |
| MDSch | [kNm] | 1270 | 1580 | 2015 | 2465 | 2990 | 3590 | 4290 | 4925 | 5910 | 6755 | 7735 | 8860 | 10040 | 11350 | | |
| M _{DW} | [kNm] | 875 | 1090 | 1390 | 1700 | 2060 | 2475 | 2960 | 3395 | 4075 | 4660 | 5335 | 6110 | 6930 | 7830 | | |
| STANDARD FLANGES SERIES F | | | | | | | | | | | | | | | | | |
| A | [mm] | 600 | 650 | 700 | 750 | 800 | 850 | 900 | 950 | 1000 | 1050 | 1100 | 1150 | 1200 | 1250 | | |
| b° |  | 5 ÷ 10 | 5 ÷ 10 | 5 ÷ 10 | 5 ÷ 10 | 5 ÷ 10 | 5 ÷ 10 | 5 ÷ 10 | 5 ÷ 10 | 5 ÷ 10 | 5 ÷ 10 | 5 ÷ 10 | 5 ÷ 10 | 5 ÷ 10 | 5 ÷ 10 | | |
| B ① | [mm] | 544 | 595 | 645 | 690 | 740 | 775 | 825 | 875 | 915 | 965 | 1015 | 1050 | 1100 | 1140 | | |
| Z (H7) | [mm] | 380 | 400 | 420 | 450 | 470 | 500 | 530 | 560 | 590 | 620 | 650 | 680 | 710 | 750 | | |
| P (h9) | [mm] | 100 | 120 | 120 | 130 | 140 | 160 | 160 | 160 | 180 | 180 | 195 | 220 | 230 | 240 | | |
| M | [mm] | 27.5 | 30 | 30 | 32.5 | 35 | 37.5 | 40 | 42.5 | 45 | 47.5 | 50 | 52.5 | 55 | 57.5 | | |
| F | [mm] | 15 | 15 | 15 | 15 | 18 | 18 | 20 | 20 | 20 | 22 | 22 | 25 | 25 | 27.5 | | |
| E | [mm] | 70 | 75 | 80 | 85 | 90 | 95 | 100 | 105 | 110 | 115 | 120 | 125 | 130 | 135 | | |
| H | [mm] | 34 | 28 | 28 | 31 | 31 | 37 | 37 | 37 | 43 | 43 | 43 | 49 | 49 | 53 | | |
| i ② | | 16 | 30 | 34 | 30 | 34 | 30 | 32 | 34 | 32 | 34 | 32 | 30 | 32 | 30 | | |
| R | [mm] | 600 | 650 | 700 | 750 | 800 | 850 | 900 | 950 | 1000 | 1050 | 1100 | 1150 | 1200 | 1250 | | |
| N | [mm] | 360 | 390 | 420 | 450 | 480 | 510 | 540 | 570 | 600 | 630 | 660 | 690 | 720 | 750 | | |
| S | | 400x8 | 440x10 | 480x10 | 530x12 | 570x12 | 610x14 | 650x14 | 690x16 | 740x16 | 780x18 | 830x18 | 880x20 | 1030x20 | 1080x20 | | |
| T | [mm] | 558.8 | 609.6 | 660.4 | 690 | 715 | 765 | 815 | 845 | 895 | 945 | 970 | 1020 | 1070 | 1120 | | |
| LARGER FLANGES SERIES J | | | | | | | | | | | | | | | | | |
| A | [mm] | 650 | 700 | 750 | 800 | 850 | 900 | 950 | 1000 | 1050 | 1100 | 1150 | 1200 | 1250 | 1300 | | |
| B ① | [mm] | 595 | 645 | 690 | 740 | 775 | 825 | 875 | 915 | 965 | 1015 | 1050 | 1100 | 1150 | 1190 | | |
| Z (H7) | [mm] | 400 | 420 | 450 | 470 | 500 | 530 | 560 | 590 | 620 | 650 | 680 | 710 | 750 | 790 | | |
| P (h9) | [mm] | 120 | 120 | 130 | 140 | 160 | 160 | 160 | 180 | 180 | 195 | 220 | 230 | 240 | 250 | | |
| M | [mm] | 30 | 30 | 32.5 | 35 | 37.5 | 40 | 42.5 | 45 | 47.5 | 50 | 52.5 | 55 | 57.5 | 60 | | |
| F | [mm] | 15 | 15 | 15 | 18 | 18 | 20 | 20 | 20 | 22 | 22 | 25 | 25 | 27.5 | 27.5 | | |
| E | [mm] | 75 | 80 | 85 | 90 | 95 | 100 | 105 | 110 | 115 | 120 | 125 | 130 | 140 | 150 | | |
| H | [mm] | 28 | 28 | 31 | 31 | 37 | 37 | 37 | 43 | 43 | 43 | 49 | 49 | 49 | 53 | | |
| i ② | | 30 | 34 | 30 | 34 | 30 | 32 | 34 | 32 | 34 | 32 | 30 | 32 | 32 | 32 | | |
| LENGTH / LENGTH COMPENSATION | | | | | | | | | | | | | | | | | |
| FF | JF | Lz | [mm] | 2630 | 2840 | 3040 | 3200 | 3410 | 3570 | 3780 | 3940 | 4140 | 4310 | 4490 | 4650 | 4850 | 4990 |
| | | La | [mm] | 300 | 300 | 350 | 350 | 400 | 400 | 450 | 450 | 500 | 500 | 550 | 550 | 600 | 600 |
| FG | JG | Lf | [mm] | 1850 | 2010 | 2150 | 2300 | 2460 | 2600 | 2760 | 2920 | 3060 | 3220 | 3360 | 3530 | 3700 | 3870 |
| FH | JH | Lf | [mm] | 1440 | 1560 | 1680 | 1800 | 1920 | 2040 | 2160 | 2280 | 2400 | 2520 | 2640 | 2760 | 2880 | 3000 |
| FK | JK | Lf | [mm] | 720 | 780 | 840 | 900 | 960 | 1020 | 1080 | 1140 | 1200 | 1260 | 1320 | 1380 | 1440 | 1500 |
| FL | JL | Lf | [mm] | 4640 | 5030 | 5420 | 5800 | 6190 | 6580 | 6960 | 7350 | 7740 | 8120 | 8500 | 8900 | 9300 | 9700 |
| FM | JM | Lz | [mm] | 3040 | 3290 | 3520 | 3710 | 3950 | 4140 | 4380 | 4580 | 4810 | 5010 | 5220 | 5410 | 5620 | 5770 |
| | | La | [mm] | 300 | 300 | 350 | 350 | 400 | 400 | 450 | 450 | 500 | 500 | 550 | 550 | 600 | 600 |

Lz = Shortest length

La = Length compensation

Lf = Shortest fix length

Length dimension (Lz and La) for reference only. Series F and J central body designed on request.

Please contact MAINA for selection of series F and J universal shafts.

① Tolerance ± 0.1 mm

② i = number of holes

TYPE WITH STANDARD FLANGE SIDE "X"

EA - Telescopic Shaft, standard type (external flange)
 EB - Telescopic Shaft, standard type (internal flange)
 EC - Telescopic Shaft, reversed type (external flange)
 ED - Telescopic Shaft, reversed type (internal flange)

TYPE WITH LARGER FLANGE SIDE "X"

HA - Telescopic Shaft, standard type (external flange)
 HB - Telescopic Shaft, standard type (internal flange)
 HC - Telescopic Shaft, reversed type (external flange)
 HD - Telescopic Shaft, reversed type (internal flange)

TABLE 7

| SIZE | | 18 | 22 | 25 | 28 | 31 | 35 | 39 | 44 | 49 | 55 | | |
|-------------------------------------|-------|--------|---------|---------|-------|-------|-------|-------|-------|-------|-------|------|------|
| RATING TORQUES | | | | | | | | | | | | | |
| Mk | [kNm] | 28 | 56 | 82 | 119 | 167 | 227 | 302 | 522 | 647 | 1031 | | |
| MDSch | [kNm] | 19 | 37 | 58 | 85 | 120 | 163 | 224 | 400 | 496 | 800 | | |
| M _{DW} | [kNm] | 12 | 24 | 37 | 54 | 76 | 106 | 146 | 262 | 321 | 516 | | |
| STANDARD FLANGE "X" SERIES E | | | | | | | | | | | | | |
| A _x ① | [mm] | 180 | 225 | 250 | 285 | 315 | 350 | 390 | 440 | 490 | 550 | | |
| B _x ② | [mm] | 155.5 | 196 | 218 | 245 | 280 | 310 | 345 | 385 | 425 | 492 | | |
| Z _x (H7) | [mm] | 90 | 105 | 105 | 125 | 130 | 155 | 170 | 190 | 205 | 250 | | |
| P _x (h9) | [mm] | 25 | 32 | 40 | 40 | 40 | 50 | 70 | 80 | 90 | 100 | | |
| M _x | [mm] | 7 | 9 | 12.5 | 15 | 15 | 16 | 18 | 20 | 22.5 | 22.5 | | |
| F _x | [mm] | 5 | 5 | 6 | 7 | 8 | 8 | 8 | 10 | 12 | 12 | | |
| E _x | [mm] | 17 | 20 | 25 | 27 | 32 | 35 | 40 | 42 | 47 | 50 | | |
| H _x | [mm] | 17 | 17 | 19 | 21 | 23 | 23 | 25 | 28 | 31 | 31 | | |
| G | [mm] | 15 | 15 | 15 | 16 | 16 | 18 | 20 | 25 | 30 | 30 | | |
| D | [mm] | 80 | 90 | 90 | 110 | 115 | 140 | 155 | 150 | 160 | 190 | | |
| R _x | [mm] | 180 | 225 | 250 | 285 | 315 | 350 | 390 | 440 | 490 | 550 | | |
| N _x | [mm] | 110 | 120 | 140 | 160 | 180 | 195 | 210 | 260 | 270 | 305 | | |
| U | [mm] | 145 | 160 | 180 | 200 | 230 | 245 | 260 | 325 | 335 | 375 | | |
| W | [mm] | 137 | 150 | 175 | 200 | 250 | 284 | 316 | 355 | 368 | 418 | | |
| S DIN 5480 ③ | | 85x2.5 | 100x2.5 | 115x2.5 | 130x3 | 150x3 | 170x5 | 185x5 | 210x5 | 210x5 | 240x5 | | |
| FLANGE "Y" | | | | | | | | | | | | | |
| A _y ① | [mm] | 250 | 315 | 330 | 390 | 435 | 480 | 520 | 600 | 650 | 710 | | |
| B _y ② | [mm] | 220 | 285 | 300 | 355 | 390 | 430 | 480 | 550 | 595 | 650 | | |
| Z _y (H7) | [mm] | 165 | 220 | 210 | 260 | 275 | 320 | 360 | 420 | 450 | 520 | | |
| P _y (h9) | [mm] | 25 | 32 | 40 | 40 | 40 | 50 | 100 | 80 | 90 | 100 | | |
| M _y | [mm] | 7 | 9 | 12.5 | 15 | 15 | 16 | 22.5 | 20 | 22.5 | 22.5 | | |
| F _y | [mm] | 5 | 5 | 6 | 7 | 8 | 8 | 12 | 12 | 12 | 15 | | |
| E _y | [mm] | 20 | 30 | 30 | 30 | 35 | 38 | 50 | 55 | 55 | 50 | | |
| H _y | [mm] | 17 | 17 | 19 | 21 | 23 | 23 | 25 | 28 | 31 | 31 | | |
| R _y | [mm] | 250 | 315 | 330 | 390 | 435 | 480 | 520 | 600 | 650 | 710 | | |
| N _y | [mm] | 120 | 130 | 145 | 160 | 180 | 210 | 230 | 280 | 290 | 320 | | |
| T | [mm] | 110 | 130 | 150 | 165 | 195 | 215 | 250 | 270 | 270 | 330 | | |
| V ④ | [mm] | 270 | 320 | 370 | 420 | 490 | 550 | 600 | 640 | 680 | 700 | | |
| K | [mm] | 37.5 | 45 | 52 | 63 | 73 | 80 | 95 | 115 | 134 | 150 | | |
| LARGER FLANGE "X" SERIES H | | | | | | | | | | | | | |
| A _x ① | [mm] | 225 | 250 | 285 | 315 | 350 | 390 | 440 | 490 | 550 | 600 | | |
| B _x ② | [mm] | 196 | 218 | 245 | 280 | 310 | 345 | 385 | 425 | 492 | 544 | | |
| Z _x (H7) | [mm] | 140 | 140 | 175 | 175 | 220 | 250 | 280 | 320 | 380 | 450 | | |
| P _x (h9) | [mm] | 32 | 40 | 40 | 40 | 50 | 70 | 80 | 90 | 100 | 100 | | |
| M _x | [mm] | 7 | 9 | 12.5 | 15 | 15 | 16 | 18 | 20 | 22.5 | 22.5 | | |
| F _x | [mm] | 5 | 6 | 7 | 7 | 8 | 8 | 8 | 10 | 12 | 15 | | |
| E _x | [mm] | 17 | 20 | 25 | 27 | 32 | 35 | 40 | 42 | 47 | 50 | | |
| H _x | [mm] | 17 | 19 | 21 | 23 | 23 | 25 | 28 | 31 | 31 | 34 | | |
| G | [mm] | 15 | 15 | 15 | 16 | 16 | 18 | 20 | 25 | 30 | 30 | | |
| D | [mm] | 80 | 90 | 90 | 110 | 115 | 140 | 155 | 150 | 160 | 190 | | |
| LENGTH / LENGTH COMPENSATION | | | | | | | | | | | | | |
| EA | HA | Lz | [mm] | 710 | 790 | 910 | 1000 | 1155 | 1300 | 1420 | 1695 | 1775 | 2000 |
| | | La | [mm] | 600 | 600 | 750 | 750 | 850 | 850 | 900 | 900 | 950 | 950 |
| | | Lt | [mm] | 1215 | 1290 | 1550 | 1770 | 1870 | 2000 | 2150 | 2385 | 2540 | 2730 |
| EB | HB | Lz | [mm] | 320 | 340 | 395 | 420 | 485 | 550 | 600 | 750 | 790 | 880 |
| | | La | [mm] | 600 | 600 | 750 | 750 | 850 | 850 | 900 | 900 | 950 | 950 |
| | | Lt | [mm] | 1355 | 1430 | 1700 | 1790 | 2055 | 2200 | 2420 | 2650 | 2780 | 2870 |
| EC | HC | Lz | [mm] | 465 | 500 | 575 | 620 | 710 | 810 | 885 | 1098 | 1155 | 1280 |
| | | La | [mm] | 600 | 600 | 750 | 750 | 850 | 850 | 900 | 900 | 950 | 950 |
| | | Lt | [mm] | 1260 | 1330 | 1590 | 1670 | 1920 | 2050 | 2240 | 2440 | 2560 | 2630 |
| ED | HD | Lz | [mm] | 470 | 530 | 620 | 680 | 795 | 890 | 960 | 1135 | 1195 | 1360 |
| | | La | [mm] | 600 | 600 | 750 | 750 | 850 | 850 | 900 | 900 | 950 | 950 |
| | | Lt | [mm] | 1215 | 1290 | 1550 | 1630 | 1870 | 2000 | 2150 | 2445 | 2530 | 2710 |

Lz = Shortest length
 La = Length compensation
 Lt = Total length

① When required tolerance h7
 ② Tolerance ± 0.1 mm
 ③ Nitrooxidated male spline shaft
 ④ For special arrangement V dimension can be modified

COMPANION FLANGES

INNER CENTERING

TYPE

FLANGE WITHOUT FACE KEY

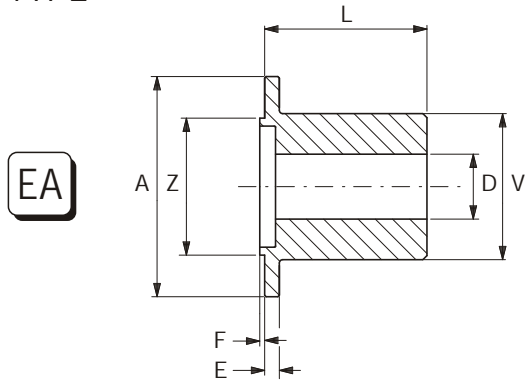

EA

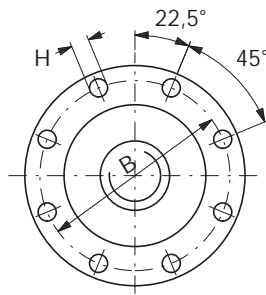

SIZE 18 - 28
8 HOLES

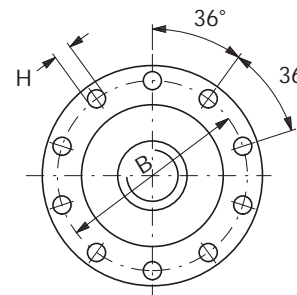

SIZE 31 - 39
10 HOLES

DOWEL PIN CONNECTION ACCORDING TO DIN 15452

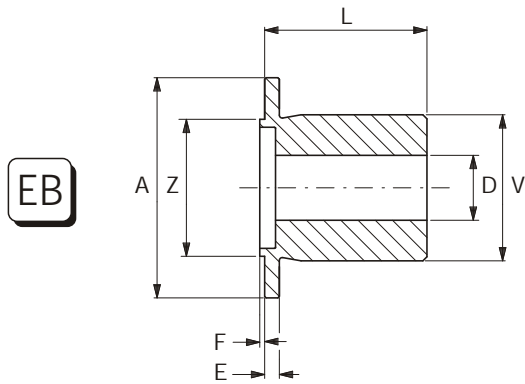

EB

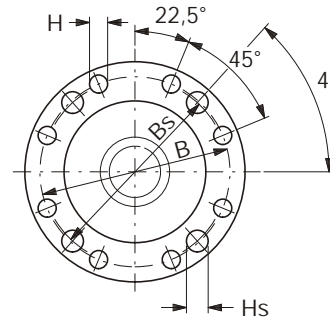

SIZE 18 - 28
8 HOLES

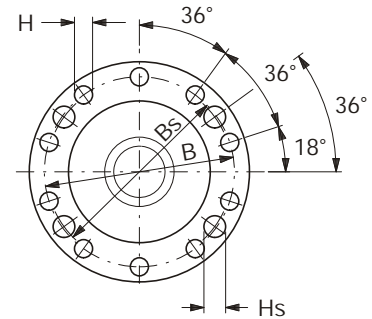

SIZE 31 - 39
10 HOLES

FLANGE WITH FACE KEY - STANDARD TYPE

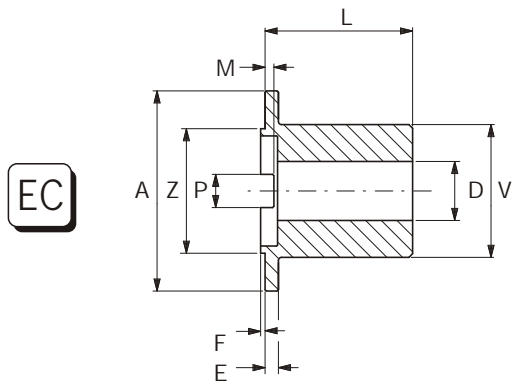

EC

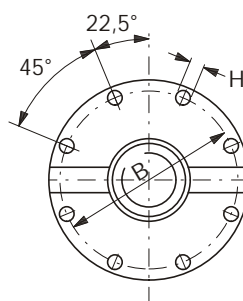

SIZE 18 - 28
8 HOLES

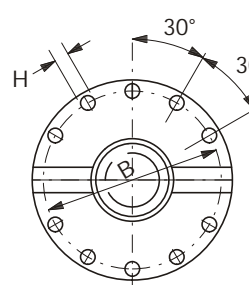

SIZE 31 - 39
10 HOLES

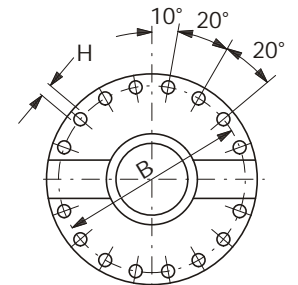

SIZE 44 - 62
16 HOLES

FLANGE WITH FACE KEY - LARGER TYPE

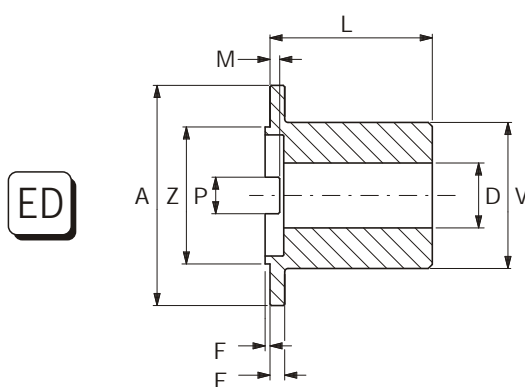

ED

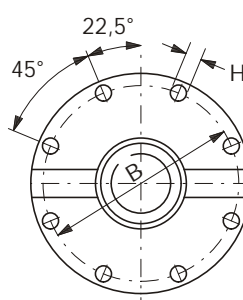

SIZE 18 - 25
8 HOLES

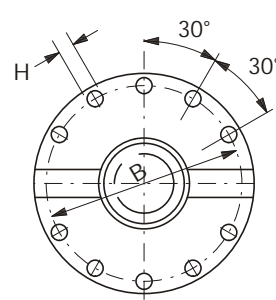

SIZE 28 - 35
10 HOLES

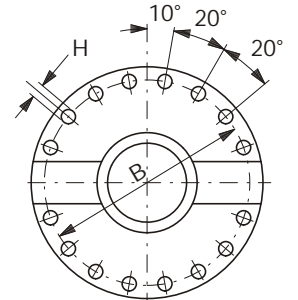

SIZE 39 - 62
16 HOLES

TABLE 8 TYPE EA

| SIZE | | 18 | 22 | 25 | 28 | 31 | 35 | 39 |
|---------|------|-----|-----|-----|-----|-----|-----|-----|
| A | [mm] | 225 | 250 | 285 | 315 | 350 | 390 | 440 |
| B ① | [mm] | 196 | 218 | 245 | 280 | 310 | 345 | 385 |
| H (C12) | [mm] | 16 | 18 | 20 | 22 | 22 | 24 | 27 |
| V ② | [mm] | 171 | 190 | 214 | 247 | 277 | 307 | 342 |
| D ③ | [mm] | 115 | 125 | 140 | 165 | 185 | 205 | 225 |
| L ④ | [mm] | 200 | 210 | 220 | 230 | 240 | 270 | 280 |
| E | [mm] | 15 | 18 | 20 | 22 | 25 | 32 | 32 |
| F | [mm] | 4 | 5 | 6 | 6 | 7 | 7 | 7 |
| Z | [mm] | 140 | 140 | 175 | 175 | 220 | 250 | 280 |
| G ⑤ | [kg] | 38 | 50 | 68 | 93 | 123 | 171 | 220 |

TABLE 9 TYPE EB

| SIZE | | 18 | 22 | 25 | 28 | 31 | 35 | 39 |
|----------|------|-----|-----|-----|-----|-----|-----|-----|
| A | [mm] | 225 | 250 | 285 | 315 | 350 | 390 | 435 |
| B ① | [mm] | 196 | 218 | 245 | 280 | 310 | 345 | 385 |
| Bs ① | [mm] | 192 | 214 | 240 | 270 | 300 | 340 | 378 |
| H (C12) | [mm] | 16 | 18 | 20 | 22 | 22 | 24 | 27 |
| Hs (H12) | [mm] | 21 | 25 | 28 | 30 | 32 | 32 | 35 |
| V ② | [mm] | 165 | 175 | 205 | 225 | 260 | 290 | 310 |
| D ③ | [mm] | 100 | 110 | 130 | 140 | 160 | 180 | 180 |
| L ④ | [mm] | 160 | 160 | 185 | 215 | 215 | 265 | 265 |
| E | [mm] | 15 | 18 | 20 | 22 | 25 | 28 | 32 |
| F | [mm] | 4 | 5 | 6 | 6 | 7 | 7 | 7 |
| Z (f8) | [mm] | 140 | 140 | 175 | 175 | 220 | 250 | 280 |
| G ⑤ | [kg] | 29 | 34 | 54 | 75 | 100 | 152 | 180 |

TABLE 10 TYPE EC

| SIZE | | 18 | 22 | 25 | 28 | 31 | 35 | 39 | 44 | 49 | 55 | 62 |
|--------|------|-------|-----|------|-----|-----|-----|-----|-----|------|------|------|
| A | [mm] | 180 | 225 | 250 | 285 | 315 | 350 | 390 | 440 | 490 | 550 | 620 |
| B ① | [mm] | 155.5 | 196 | 218 | 245 | 280 | 310 | 345 | 385 | 425 | 492 | 555 |
| H | [mm] | 17 | 17 | 19 | 21 | 23 | 23 | 25 | 28 | 31 | 31 | 37 |
| V ② | [mm] | 130.5 | 171 | 190 | 214 | 247 | 277 | 307 | 342 | 378 | 445 | 499 |
| D ③ | [mm] | 90 | 115 | 125 | 140 | 165 | 185 | 205 | 225 | 255 | 295 | 335 |
| L ④ | [mm] | 170 | 200 | 210 | 220 | 230 | 240 | 270 | 280 | 300 | 320 | 360 |
| E | [mm] | 17 | 20 | 25 | 27 | 32 | 35 | 40 | 42 | 47 | 50 | 55 |
| F | [mm] | 4 | 4 | 5 | 6 | 7 | 7 | 7 | 9 | 11 | 11 | 14 |
| P | [mm] | 25 | 32 | 40 | 40 | 40 | 50 | 70 | 80 | 90 | 100 | 110 |
| M | [mm] | 7 | 9 | 12.5 | 15 | 15 | 16 | 18 | 20 | 22.5 | 22.5 | 27.5 |
| Z (f8) | [mm] | 90 | 105 | 105 | 125 | 130 | 155 | 170 | 190 | 205 | 250 | 280 |
| G ⑤ | [kg] | 20 | 39 | 51 | 68 | 95 | 124 | 172 | 224 | 295 | 427 | 598 |

TABLE 11 TYPE ED

| SIZE | | 18 | 22 | 25 | 28 | 31 | 35 | 39 | 44 | 49 | 55 | 62 |
|--------|------|-----|-----|------|-----|-----|-----|-----|-----|------|------|------|
| A | [mm] | 225 | 250 | 285 | 315 | 350 | 390 | 440 | 490 | 550 | 600 | 680 |
| B ① | [mm] | 196 | 218 | 245 | 280 | 310 | 345 | 385 | 425 | 492 | 544 | 615 |
| H | [mm] | 17 | 19 | 21 | 23 | 23 | 25 | 28 | 31 | 31 | 34 | 37 |
| V ② | [mm] | 171 | 190 | 214 | 247 | 277 | 307 | 342 | 378 | 445 | 493 | 599 |
| D ③ | [mm] | 115 | 125 | 140 | 165 | 185 | 205 | 225 | 255 | 295 | 325 | 370 |
| L ④ | [mm] | 200 | 210 | 220 | 230 | 240 | 270 | 280 | 300 | 320 | 350 | 400 |
| E | [mm] | 17 | 20 | 25 | 27 | 32 | 35 | 40 | 42 | 47 | 50 | 55 |
| F | [mm] | 4 | 5 | 6 | 6 | 7 | 7 | 7 | 9 | 11 | 14 | 14 |
| P | [mm] | 32 | 40 | 40 | 40 | 50 | 70 | 80 | 90 | 100 | 100 | 110 |
| M | [mm] | 7 | 9 | 12.5 | 15 | 15 | 16 | 18 | 20 | 22.5 | 22.5 | 27.5 |
| Z (f8) | [mm] | 140 | 140 | 175 | 175 | 220 | 250 | 280 | 320 | 380 | 450 | 450 |
| G ⑤ | [kg] | 38 | 50 | 68 | 94 | 124 | 172 | 224 | 295 | 431 | 574 | 920 |

① Tolerance ± 0.1 mm

② Maximum values

③ Maximum finished bore diameter

④ Different lengths on request

⑤ G = weight calculated for solid hub

COMPANION FLANGES

OUTER CENTERING

TYPE

FLANGE WITHOUT FACE KEY

EE

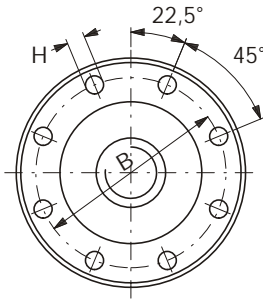
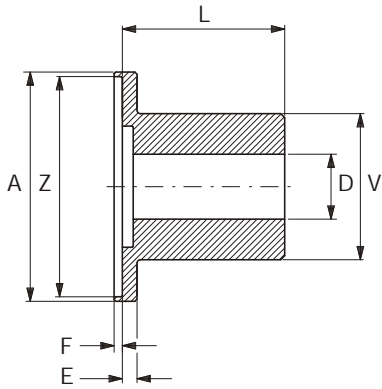

SIZE 18 - 28
8 HOLES

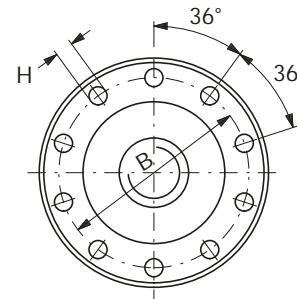

SIZE 31 - 39
10 HOLES

DOWEL PIN CONNECTION ACCORDING TO DIN 15452

EF

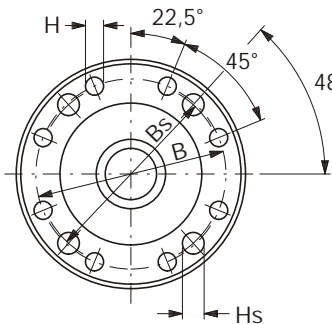
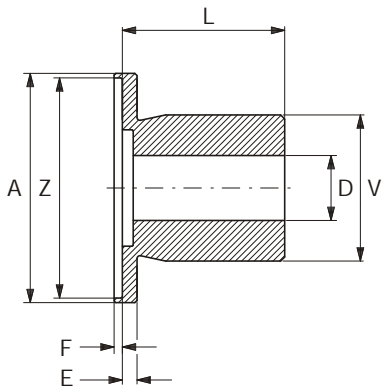

SIZE 18 - 28
8 HOLES

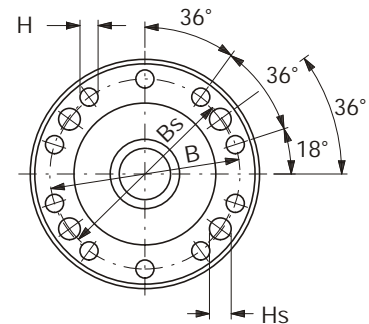

SIZE 31 - 39
10 HOLES

FLANGE WITH FACE KEY - STANDARD TYPE

EG

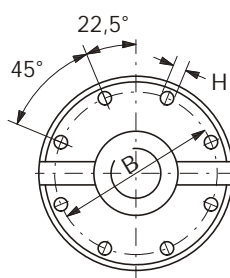
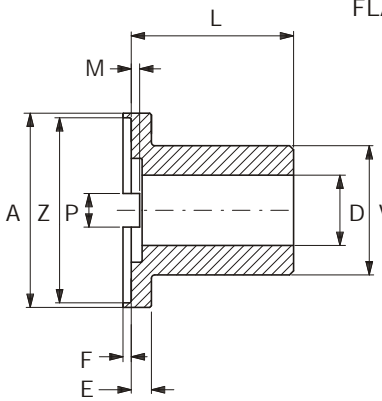

SIZE 18 - 28
8 HOLES

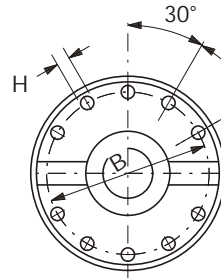

SIZE 31 - 39
10 HOLES

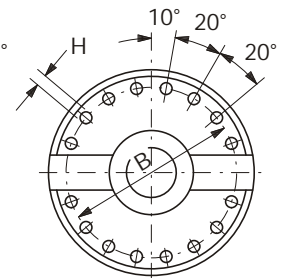

SIZE 44 - 62
16 HOLES

FLANGE WITH FACE KEY - LARGER TYPE

EH

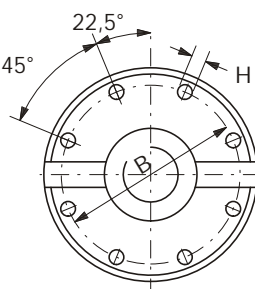
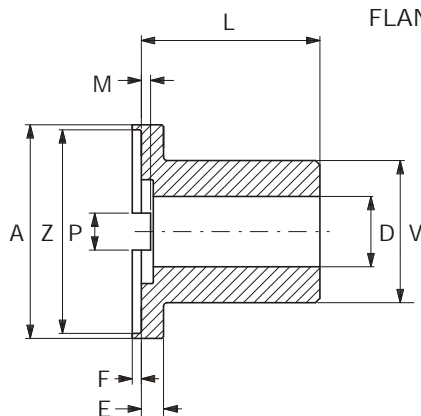

SIZE 18 - 25
8 HOLES

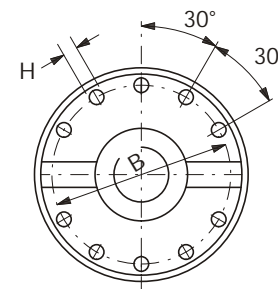

SIZE 28 - 35
10 HOLES

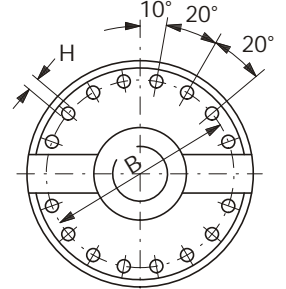

SIZE 39 - 62
16 HOLES

TABLE 12
TYPE EE

| SIZE | | 18 | 22 | 25 | 28 | 31 | 35 | 39 |
|---------|------|-----|-----|-----|-----|-----|-----|-----|
| A | [mm] | 235 | 260 | 295 | 330 | 365 | 405 | 460 |
| B ① | [mm] | 196 | 218 | 245 | 280 | 310 | 345 | 385 |
| H (C12) | [mm] | 16 | 18 | 20 | 22 | 22 | 24 | 27 |
| V ② | [mm] | 171 | 190 | 214 | 247 | 277 | 307 | 342 |
| D ③ | [mm] | 115 | 125 | 140 | 165 | 185 | 205 | 225 |
| L ④ | [mm] | 200 | 210 | 220 | 230 | 240 | 270 | 280 |
| E | [mm] | 15 | 18 | 20 | 22 | 25 | 32 | 32 |
| F | [mm] | 4 | 5 | 6 | 6 | 7 | 7 | 7 |
| Z (H7) | [mm] | 225 | 250 | 285 | 315 | 350 | 390 | 440 |
| G ⑤ | [kg] | 38 | 50 | 68 | 93 | 123 | 171 | 220 |

TABLE 13
TYPE EF

| SIZE | | 18 | 22 | 25 | 28 | 31 | 35 | 39 |
|----------|------|-----|-----|-----|-----|-----|-----|-----|
| A | [mm] | 235 | 260 | 295 | 330 | 365 | 405 | 455 |
| B ① | [mm] | 196 | 218 | 245 | 280 | 310 | 345 | 385 |
| Bs ① | [mm] | 192 | 214 | 240 | 270 | 300 | 340 | 378 |
| H (C12) | [mm] | 16 | 18 | 20 | 22 | 22 | 24 | 27 |
| Hs (H12) | [mm] | 21 | 25 | 28 | 30 | 32 | 32 | 35 |
| V ② | [mm] | 165 | 175 | 205 | 225 | 260 | 290 | 310 |
| D ③ | [mm] | 100 | 110 | 130 | 140 | 160 | 180 | 180 |
| L ④ | [mm] | 160 | 160 | 185 | 215 | 215 | 265 | 265 |
| E | [mm] | 15 | 18 | 20 | 22 | 25 | 28 | 32 |
| F | [mm] | 4 | 5 | 6 | 6 | 7 | 7 | 7 |
| Z (H7) | [mm] | 225 | 250 | 285 | 315 | 350 | 390 | 435 |
| G ⑤ | [kg] | 29 | 34 | 54 | 75 | 100 | 152 | 180 |

TABLE 14
TYPE EG

| SIZE | | 18 | 22 | 25 | 28 | 31 | 35 | 39 | 44 | 49 | 55 | 62 |
|--------|------|-------|-----|------|-----|-----|-----|-----|-----|------|------|------|
| A | [mm] | 190 | 235 | 260 | 295 | 330 | 365 | 405 | 460 | 510 | 570 | 640 |
| B ① | [mm] | 155.5 | 196 | 218 | 245 | 280 | 310 | 345 | 385 | 425 | 492 | 555 |
| H | [mm] | 17 | 17 | 19 | 21 | 23 | 23 | 25 | 28 | 31 | 31 | 37 |
| V ② | [mm] | 130.5 | 171 | 190 | 214 | 247 | 277 | 307 | 342 | 378 | 445 | 499 |
| D ③ | [mm] | 90 | 115 | 125 | 140 | 165 | 185 | 205 | 225 | 255 | 295 | 335 |
| L ④ | [mm] | 170 | 200 | 210 | 220 | 230 | 240 | 270 | 280 | 300 | 320 | 360 |
| E | [mm] | 17 | 20 | 25 | 27 | 32 | 35 | 40 | 42 | 47 | 50 | 55 |
| F | [mm] | 4 | 4 | 5 | 6 | 7 | 7 | 7 | 9 | 11 | 11 | 14 |
| P | [mm] | 25 | 32 | 40 | 40 | 40 | 50 | 70 | 80 | 90 | 100 | 110 |
| M | [mm] | 7 | 9 | 12.5 | 15 | 15 | 16 | 18 | 20 | 22.5 | 22.5 | 27.5 |
| Z (H7) | [mm] | 180 | 225 | 250 | 285 | 315 | 350 | 390 | 440 | 490 | 550 | 620 |
| G ⑤ | [kg] | 20 | 39 | 51 | 68 | 95 | 124 | 172 | 224 | 295 | 427 | 610 |

TABLE 15
TYPE EH

| SIZE | | 18 | 22 | 25 | 28 | 31 | 35 | 39 | 44 | 49 | 55 | 62 |
|--------|------|-----|-----|------|-----|-----|-----|-----|-----|------|------|------|
| A | [mm] | 235 | 260 | 295 | 330 | 365 | 405 | 460 | 510 | 570 | 620 | 700 |
| B ① | [mm] | 196 | 218 | 245 | 280 | 310 | 345 | 385 | 425 | 492 | 544 | 615 |
| H | [mm] | 17 | 19 | 21 | 23 | 23 | 25 | 28 | 31 | 31 | 34 | 37 |
| V ② | [mm] | 171 | 190 | 214 | 247 | 277 | 307 | 342 | 378 | 445 | 493 | 599 |
| D ③ | [mm] | 115 | 125 | 140 | 165 | 185 | 205 | 225 | 255 | 295 | 325 | 370 |
| L ④ | [mm] | 200 | 210 | 220 | 230 | 240 | 270 | 280 | 300 | 320 | 350 | 400 |
| E | [mm] | 17 | 20 | 25 | 27 | 32 | 35 | 40 | 42 | 47 | 50 | 55 |
| F | [mm] | 4 | 5 | 6 | 6 | 7 | 7 | 7 | 9 | 11 | 14 | 14 |
| P | [mm] | 32 | 40 | 40 | 40 | 50 | 70 | 80 | 90 | 100 | 100 | 110 |
| M | [mm] | 7 | 9 | 12.5 | 15 | 15 | 16 | 18 | 20 | 22.5 | 22.5 | 27.5 |
| Z (H7) | [mm] | 225 | 250 | 285 | 315 | 350 | 390 | 440 | 490 | 550 | 600 | 680 |
| G ⑤ | [kg] | 38 | 50 | 68 | 94 | 124 | 172 | 224 | 295 | 431 | 574 | 870 |

 ① Tolerance ± 0.1 mm

② Maximum values

③ Maximum finished bore diameter

④ Different lengths on request

⑤ G = weight calculated for solid hub

CYLINDRICAL COMPANION FLANGES

INNER CENTERING

TYPE

FLANGE WITHOUT FACE KEY

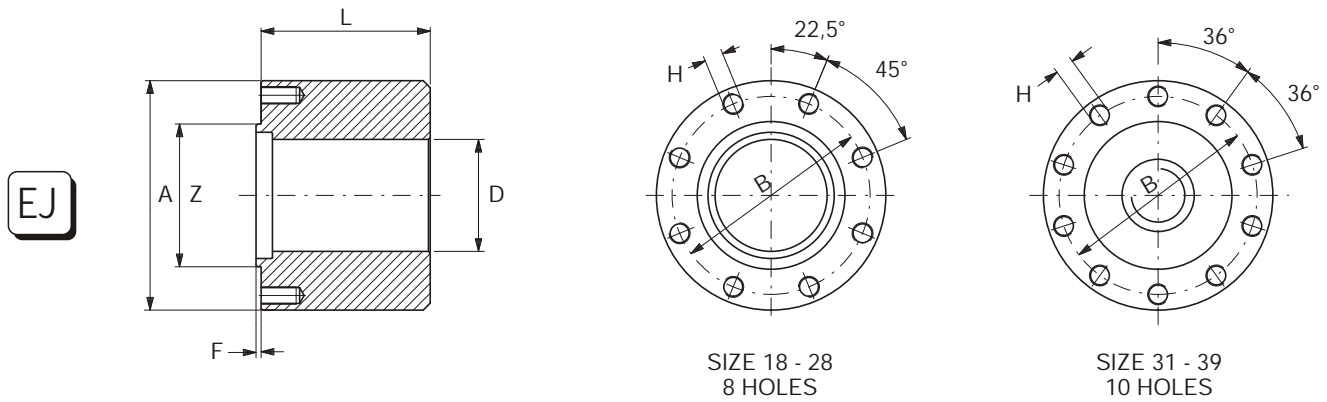

FLANGE WITH FACE KEY - STANDARD TYPE

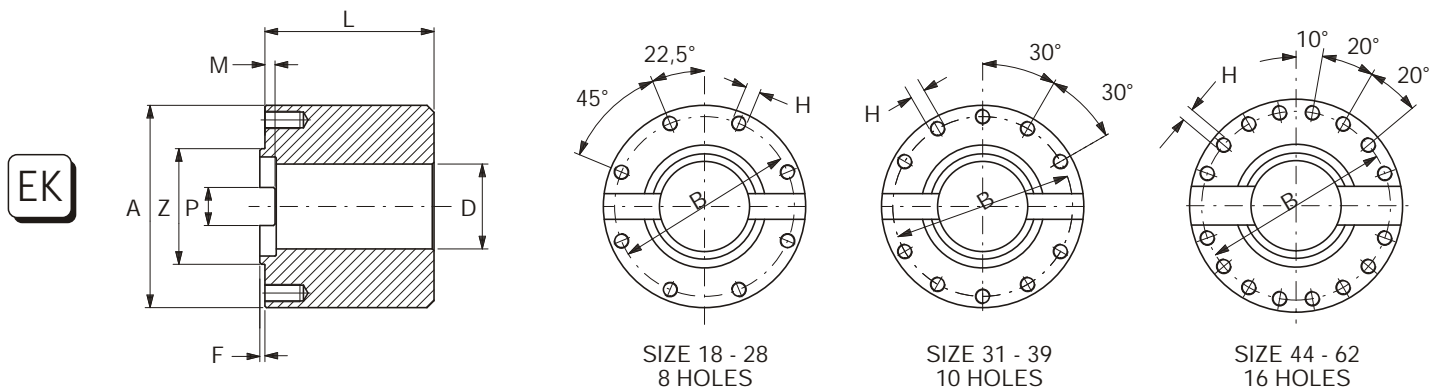

FLANGE WITH FACE KEY - LARGER TYPE

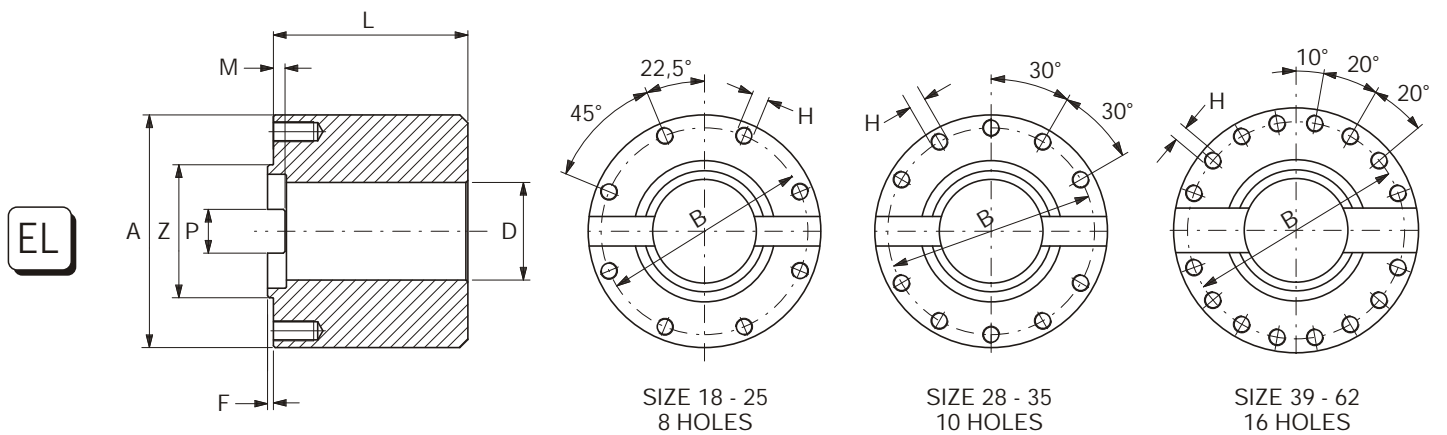

TABLE 16
TYPE EJ

| SIZE | | 18 | 22 | 25 | 28 | 31 | 35 | 39 |
|--------|------|-----|-----|-----|-----|-----|-----|-----|
| A | [mm] | 225 | 250 | 285 | 315 | 350 | 390 | 440 |
| B ① | [mm] | 196 | 218 | 245 | 280 | 310 | 345 | 385 |
| H | [mm] | M16 | M18 | M20 | M22 | M22 | M24 | M27 |
| D ② | [mm] | 150 | 170 | 190 | 210 | 235 | 260 | 295 |
| L ③ | [mm] | 200 | 210 | 220 | 230 | 240 | 270 | 280 |
| F | [mm] | 4 | 5 | 6 | 6 | 7 | 7 | 7 |
| Z (f8) | [mm] | 140 | 140 | 175 | 175 | 220 | 250 | 280 |
| G ④ | [kg] | 62 | 81 | 111 | 142 | 183 | 255 | 337 |

TABLE 17
TYPE EK

| SIZE | | 18 | 22 | 25 | 28 | 31 | 35 | 39 | 44 | 49 | 55 | 62 |
|--------|------|-------|-----|------|-----|-----|-----|-----|-----|------|------|------|
| A | [mm] | 180 | 225 | 250 | 285 | 315 | 350 | 390 | 440 | 490 | 550 | 620 |
| B ① | [mm] | 155.5 | 196 | 218 | 245 | 280 | 310 | 345 | 385 | 425 | 492 | 555 |
| H | [mm] | M16 | M16 | M18 | M20 | M22 | M22 | M24 | M27 | M30 | M30 | M36 |
| D ② | [mm] | 120 | 150 | 170 | 190 | 210 | 235 | 260 | 295 | 325 | 365 | 420 |
| L ③ | [mm] | 170 | 200 | 210 | 220 | 230 | 240 | 270 | 280 | 300 | 320 | 360 |
| F | [mm] | 4 | 4 | 5 | 6 | 7 | 7 | 7 | 9 | 11 | 11 | 14 |
| P | [mm] | 25 | 32 | 40 | 40 | 40 | 50 | 70 | 80 | 90 | 100 | 110 |
| M | [mm] | 7 | 9 | 12.5 | 15 | 15 | 16 | 18 | 20 | 22.5 | 22.5 | 27.5 |
| Z (f8) | [mm] | 90 | 105 | 105 | 125 | 130 | 155 | 170 | 190 | 205 | 250 | 280 |
| G ④ | [kg] | 34 | 62 | 81 | 111 | 142 | 183 | 255 | 337 | 447 | 600 | 860 |

TABLE 18
TYPE EL

| SIZE | | 18 | 22 | 25 | 28 | 31 | 35 | 39 | 44 | 49 | 55 | 62 |
|--------|------|-----|-----|------|-----|-----|-----|-----|-----|------|------|------|
| A | [mm] | 225 | 250 | 285 | 315 | 350 | 390 | 440 | 490 | 550 | 600 | 680 |
| B ① | [mm] | 196 | 218 | 245 | 280 | 310 | 345 | 385 | 425 | 492 | 544 | 615 |
| H | [mm] | M16 | M18 | M20 | M22 | M22 | M24 | M27 | M30 | M30 | M33 | M36 |
| D ② | [mm] | 150 | 170 | 190 | 210 | 235 | 260 | 295 | 325 | 365 | 400 | 450 |
| L ③ | [mm] | 200 | 210 | 220 | 230 | 240 | 270 | 280 | 300 | 320 | 350 | 400 |
| F | [mm] | 4 | 5 | 6 | 6 | 7 | 7 | 7 | 9 | 11 | 14 | 14 |
| P | [mm] | 32 | 40 | 40 | 40 | 50 | 70 | 80 | 90 | 100 | 100 | 110 |
| M | [mm] | 7 | 9 | 12.5 | 15 | 15 | 16 | 18 | 20 | 22.5 | 22.5 | 27.5 |
| Z (f8) | [mm] | 140 | 140 | 175 | 175 | 220 | 250 | 280 | 320 | 380 | 450 | 450 |
| G ④ | [kg] | 62 | 81 | 111 | 142 | 183 | 255 | 337 | 447 | 600 | 794 | 1150 |

 ① Tolerance ± 0.1 mm

② Maximum finished bore diameter

③ Different lengths on request

④ G = weight calculated for solid hub

CYLINDRICAL COMPANION FLANGES

OUTER CENTERING

TYPE

FLANGE WITHOUT FACE KEY

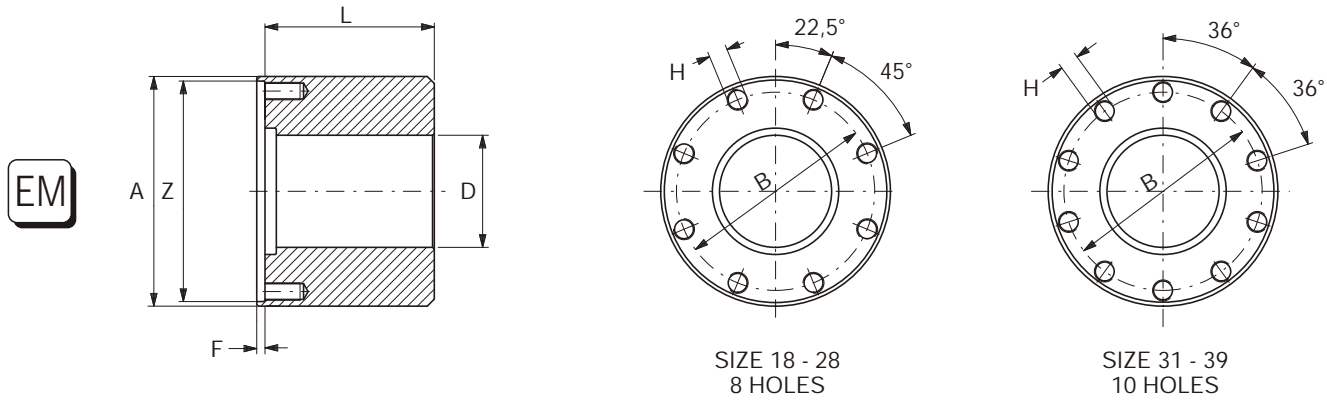

FLANGE WITH FACE KEY - STANDARD TYPE

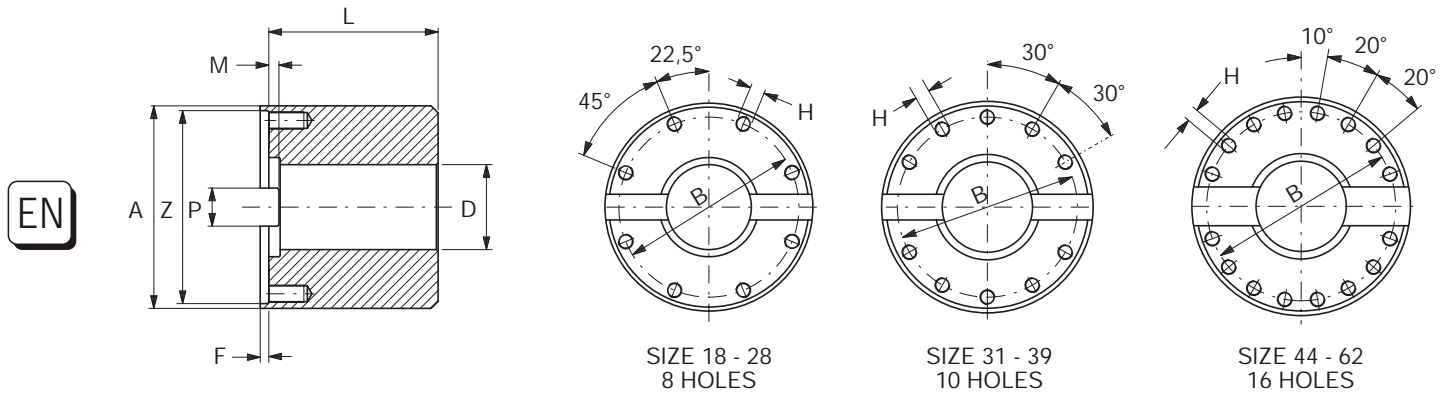

FLANGE WITH FACE KEY - LARGER TYPE

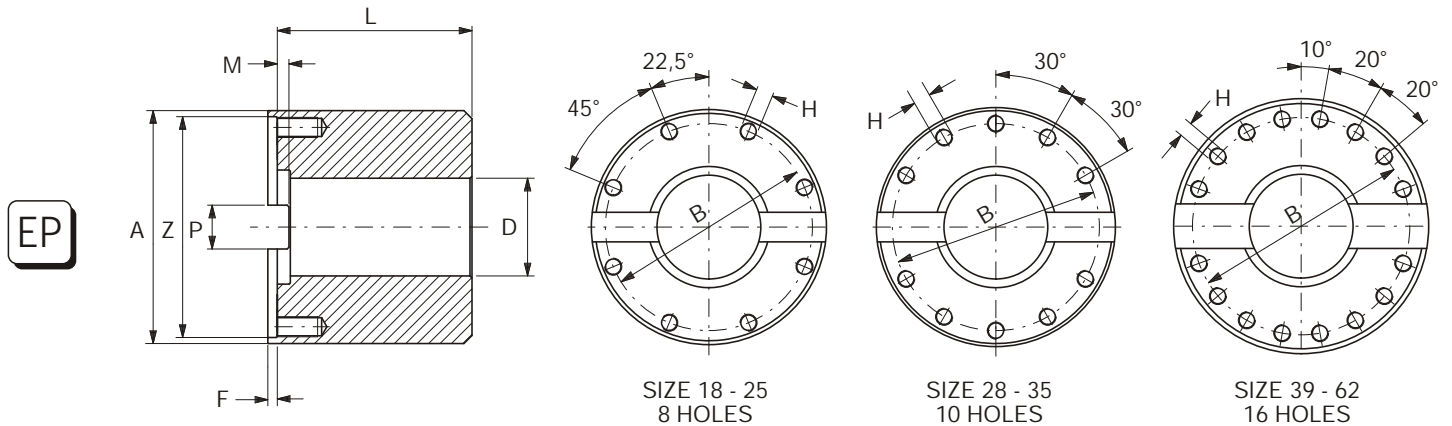

TABLE 19
TYPE EM

| SIZE | | 18 | 22 | 25 | 28 | 31 | 35 | 39 |
|--------|------|-----|-----|-----|-----|-----|-----|-----|
| A | [mm] | 235 | 260 | 295 | 330 | 365 | 405 | 460 |
| B ① | [mm] | 196 | 218 | 245 | 280 | 310 | 345 | 385 |
| H | [mm] | M16 | M18 | M20 | M22 | M22 | M24 | M27 |
| D ② | [mm] | 155 | 175 | 195 | 220 | 245 | 270 | 310 |
| L ③ | [mm] | 200 | 210 | 220 | 230 | 240 | 270 | 280 |
| F | [mm] | 4 | 5 | 6 | 6 | 7 | 7 | 7 |
| Z (H7) | [mm] | 225 | 250 | 285 | 315 | 350 | 390 | 440 |
| G ④ | [kg] | 68 | 87 | 118 | 155 | 197 | 275 | 365 |

TABLE 20
TYPE EN

| SIZE | | 18 | 22 | 25 | 28 | 31 | 35 | 39 | 44 | 49 | 55 | 62 |
|--------|------|-------|-----|------|-----|-----|-----|-----|-----|------|------|------|
| A | [mm] | 190 | 235 | 260 | 295 | 330 | 365 | 405 | 460 | 510 | 570 | 640 |
| B ① | [mm] | 155.5 | 196 | 218 | 245 | 280 | 310 | 345 | 385 | 425 | 492 | 555 |
| H | [mm] | M16 | M16 | M18 | M20 | M22 | M22 | M24 | M27 | M30 | M30 | M36 |
| D ② | [mm] | 125 | 155 | 175 | 195 | 220 | 245 | 270 | 310 | 340 | 380 | 420 |
| L ③ | [mm] | 170 | 200 | 210 | 220 | 230 | 240 | 270 | 280 | 300 | 320 | 360 |
| F | [mm] | 4 | 4 | 5 | 6 | 7 | 7 | 7 | 9 | 11 | 11 | 14 |
| P | [mm] | 25 | 32 | 40 | 40 | 40 | 50 | 70 | 80 | 90 | 100 | 110 |
| M | [mm] | 7 | 9 | 12.5 | 15 | 15 | 16 | 18 | 20 | 22.5 | 22.5 | 27.5 |
| Z (H7) | [mm] | 180 | 225 | 250 | 285 | 315 | 350 | 390 | 440 | 490 | 550 | 620 |
| G ④ | [kg] | 36 | 68 | 87 | 118 | 155 | 197 | 275 | 365 | 481 | 641 | 910 |

TABLE 21
TYPE EP

| SIZE | | 18 | 22 | 25 | 28 | 31 | 35 | 39 | 44 | 49 | 55 | 62 |
|--------|------|-----|-----|------|-----|-----|-----|-----|-----|------|------|------|
| A | [mm] | 235 | 260 | 295 | 330 | 365 | 405 | 460 | 510 | 570 | 620 | 700 |
| B ① | [mm] | 196 | 218 | 245 | 280 | 310 | 345 | 385 | 425 | 492 | 544 | 615 |
| H | [mm] | M16 | M18 | M20 | M22 | M22 | M24 | M27 | M30 | M30 | M33 | M36 |
| D ② | [mm] | 155 | 175 | 195 | 220 | 245 | 270 | 310 | 340 | 380 | 415 | 450 |
| L ③ | [mm] | 200 | 210 | 220 | 230 | 240 | 270 | 280 | 300 | 320 | 350 | 400 |
| F | [mm] | 4 | 5 | 6 | 6 | 7 | 7 | 7 | 9 | 11 | 14 | 14 |
| P | [mm] | 32 | 40 | 40 | 40 | 50 | 70 | 80 | 90 | 100 | 100 | 110 |
| M | [mm] | 7 | 9 | 12.5 | 15 | 15 | 16 | 18 | 20 | 22.5 | 22.5 | 27.5 |
| Z (H7) | [mm] | 225 | 250 | 285 | 315 | 350 | 390 | 440 | 490 | 550 | 600 | 680 |
| G ④ | [kg] | 68 | 87 | 118 | 155 | 197 | 275 | 365 | 481 | 641 | 830 | 1210 |

 ① Tolerance ± 0.1 mm

② Maximum finished bore diameter

③ Different lengths on request

④ G = weight calculated for solid hub

BORE DESIGNS

TYPE OF FITTING

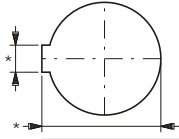
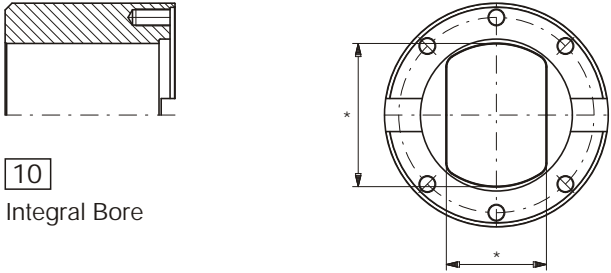
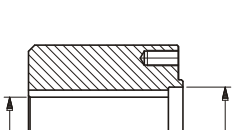
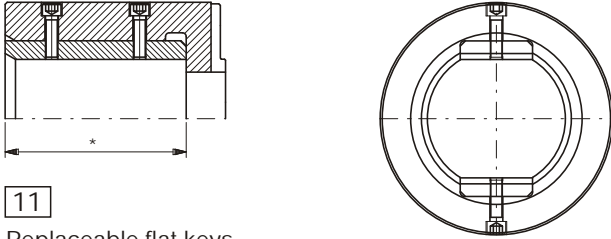
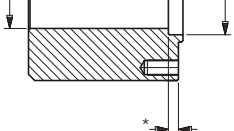
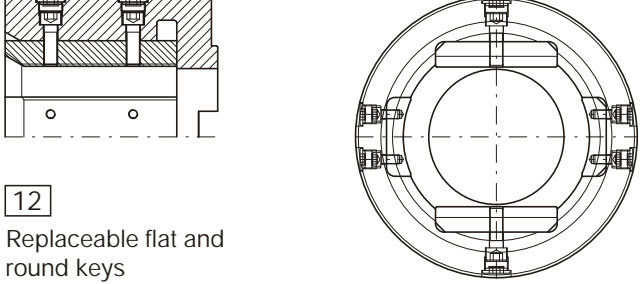
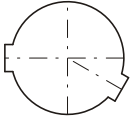
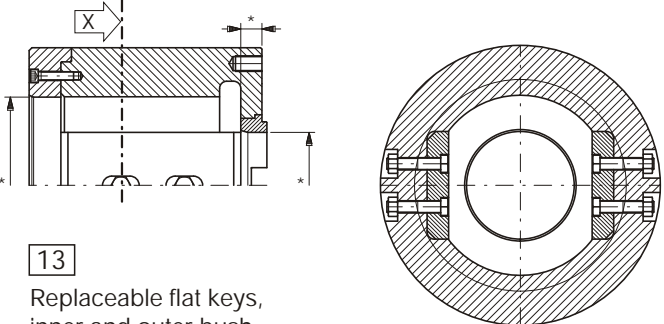
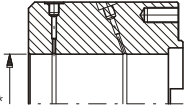
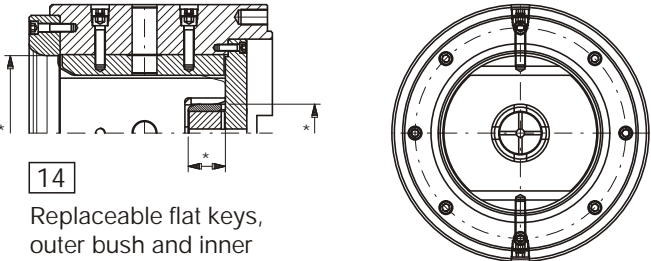
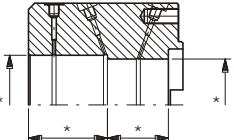
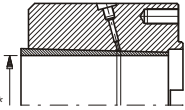
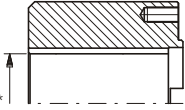
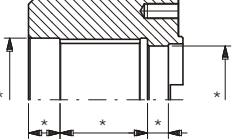
| | |
|---|--|
|  <p>01 Cylindrical Bore, 1 keyway</p> |  <p>10 Integral Bore</p> |
|  <p>02 Cylindrical Bore, 2 keyways at 90°</p> |  <p>11 Replaceable flat keys</p> |
|  <p>03 Cylindrical Bore, 2 keyways at 180°</p> |  <p>12 Replaceable flat and round keys</p> |
|  <p>04 Cylindrical Bore, 2 keyways at 120°</p> |  <p>13 Replaceable flat keys, inner and outer bush</p> <p>X - SECTION</p> |
|  <p>05 Cylindrical Bore for fitting and oil pressure removal</p> |  <p>14 Replaceable flat keys, outer bush and inner centering</p> |
|  <p>06 Cylindrical Bore with 2 diameters for fitting and oil pressure removal</p> | |
|  <p>07 Taper Bore and Taper Bush for fitting and oil pressure removal</p> | |
|  <p>08 DIN 5480 Splined Bore, or equal, without centerings</p> | |
|  <p>09 DIN 5480 Splined Bore, or equal, with centering diameters</p> | |

Companion flanges type 01 ÷ 04 are usually made of AISI 1045 hardened and tempered whereas type 05 ÷ 14 of AISI 4140 hardened and tempered.
Companion flanges type 10 ÷ 14 have hardened contact surfaces.
For inquiries please send us dimensions indicated with * and, for type 10 ÷ 14, a general drawing.

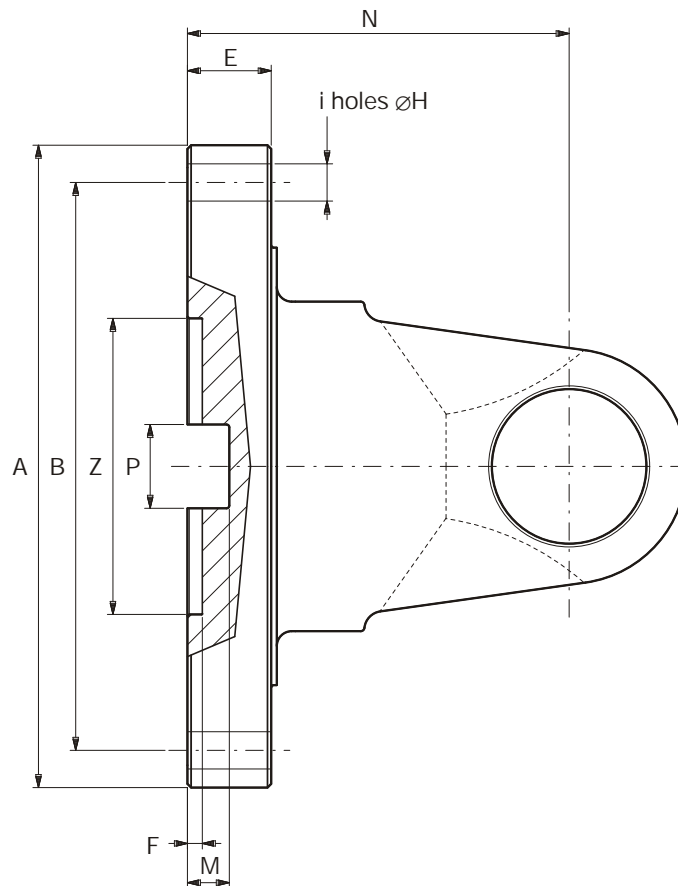

TABLE 22

| SIZE | | 18 | 22 | 25 | 28 | 31 | 35 | 39 | 44 | 49 | 55 | 62 |
|--------|------|-----|-----|------|-----|-----|-----|-----|-----|------|------|-----|
| A | [mm] | 250 | 285 | 315 | 350 | 390 | 440 | 490 | 550 | 600 | 650 | 700 |
| B | [mm] | 218 | 245 | 280 | 310 | 345 | 385 | 425 | 492 | 544 | 595 | 645 |
| Z (H7) | [mm] | 140 | 175 | 175 | 220 | 250 | 280 | 320 | 380 | 450 | 490 | 500 |
| P | [mm] | 40 | 40 | 40 | 50 | 70 | 80 | 90 | 100 | 100 | 120 | 130 |
| M | [mm] | 7 | 9 | 12.5 | 15 | 15 | 16 | 18 | 20 | 22.5 | 22.5 | 30 |
| F | [mm] | 5 | 6 | 7 | 7 | 8 | 8 | 8 | 10 | 12 | 15 | 15 |
| E | [mm] | 17 | 20 | 25 | 27 | 32 | 35 | 40 | 42 | 47 | 50 | 70 |
| H | [mm] | 19 | 21 | 23 | 23 | 25 | 28 | 31 | 31 | 34 | 28 | 28 |
| i | | 8 | 8 | 10 | 10 | 10 | 16 | 16 | 16 | 16 | 30 | 34 |
| N | [mm] | 140 | 155 | 180 | 205 | 235 | 255 | 275 | 325 | 345 | 385 | 430 |

For identification see pages 48 and 49.

EXAMPLE: EXTRA LARGE FLANGE SIZE 22

CODE: DB.C2201.285 where 285 is "A" dimension

Different dimensions on request

HIRTH - SERRATION

ENGINEERING DATA

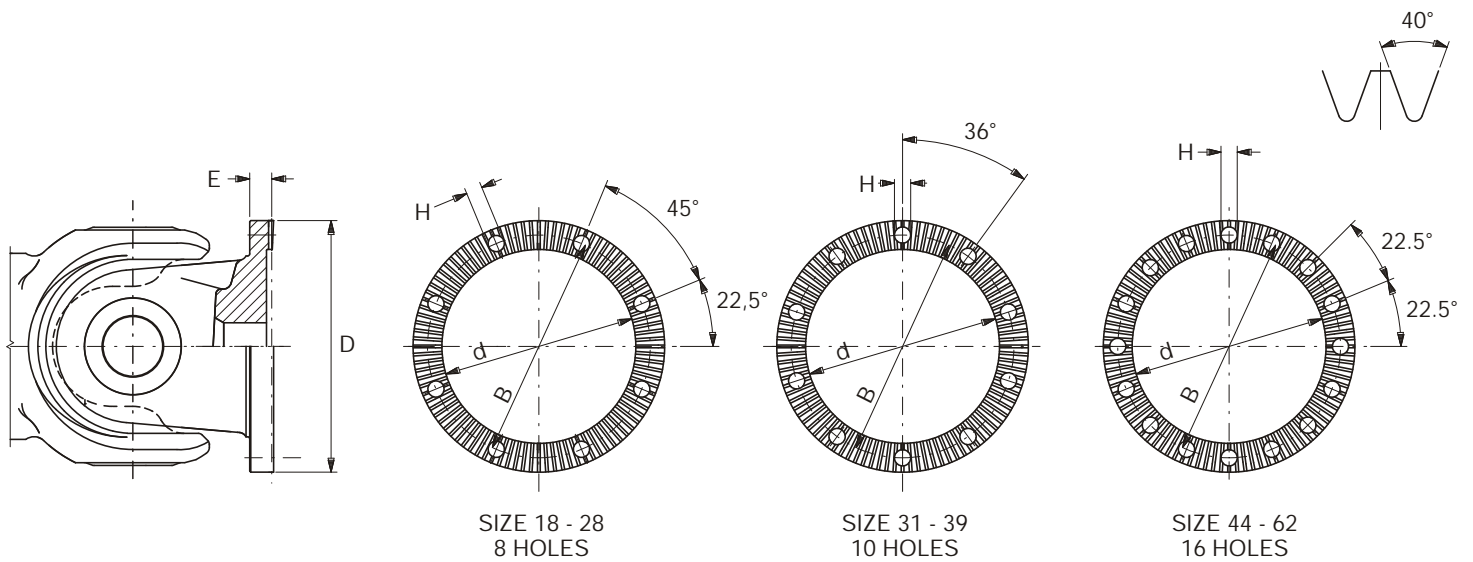

TABLE 23

| D | [mm] | 180 | 225 | 250 | 285 | 315 | 350 | 390 | 440 | 490 | 550 | 620 |
|-----|------|-----|-----|-----|-----|-----|-----|-----|-----|-----|-----|-----|
| d | [mm] | 140 | 180 | 200 | 225 | 250 | 280 | 315 | 340 | 380 | 440 | 500 |
| B ① | [mm] | 160 | 203 | 225 | 255 | 280 | 315 | 350 | 400 | 450 | 510 | 575 |
| H | [mm] | 13 | 13 | 15 | 17 | 19 | 19 | 21 | 21 | 23 | 23 | 25 |
| E | [mm] | 17 | 20 | 25 | 27 | 32 | 35 | 40 | 42 | 47 | 50 | 55 |
| z ② | | 36 | 48 | 48 | 60 | 60 | 72 | 72 | 96 | 96 | 96 | 120 |

① Tolerance ± 0.1 mm

② z = number of teeth

Different hole patterns may be checked for special applications.

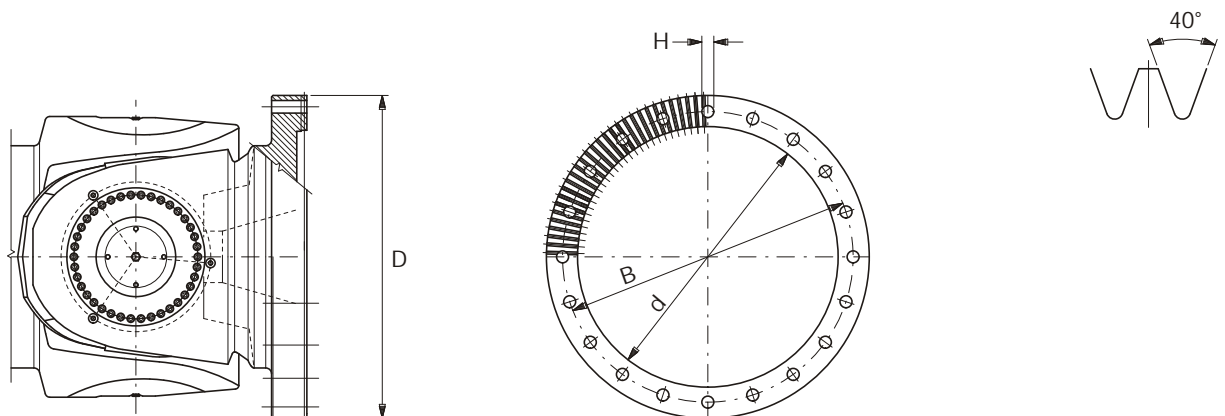

TABLE 24

| D | [mm] | 600 | 650 | 700 | 750 | 800 | 850 | 900 | 950 | 1000 | 1050 | 1100 | 1150 | 1200 | 1250 | 1300 |
|-----|------|-----|-----|-----|-----|-----|-----|-----|-----|------|------|------|------|------|------|------|
| d | [mm] | 480 | 520 | 570 | 610 | 650 | 680 | 710 | 760 | 800 | 840 | 880 | 925 | 960 | 1000 | 1040 |
| B ① | [mm] | 555 | 595 | 645 | 695 | 740 | 790 | 825 | 875 | 915 | 965 | 1015 | 1050 | 1100 | 1140 | 1190 |
| H | [mm] | 25 | 28 | 28 | 31 | 31 | 31 | 37 | 37 | 43 | 43 | 43 | 49 | 49 | 53 | 53 |
| i ② | | 30 | 30 | 30 | 32 | 32 | 36 | 32 | 32 | 30 | 30 | 30 | 30 | 30 | 30 | 30 |
| E | [mm] | 70 | 75 | 80 | 85 | 90 | 95 | 100 | 105 | 110 | 115 | 120 | 125 | 130 | 135 | 140 |
| z ③ | | 120 | 120 | 120 | 144 | 144 | 144 | 144 | 144 | 180 | 180 | 180 | 180 | 180 | 180 | 180 |

① Tolerance ± 0.1 mm

② i = number of holes

③ z = number of teeth

Different hole patterns may be checked for special applications.

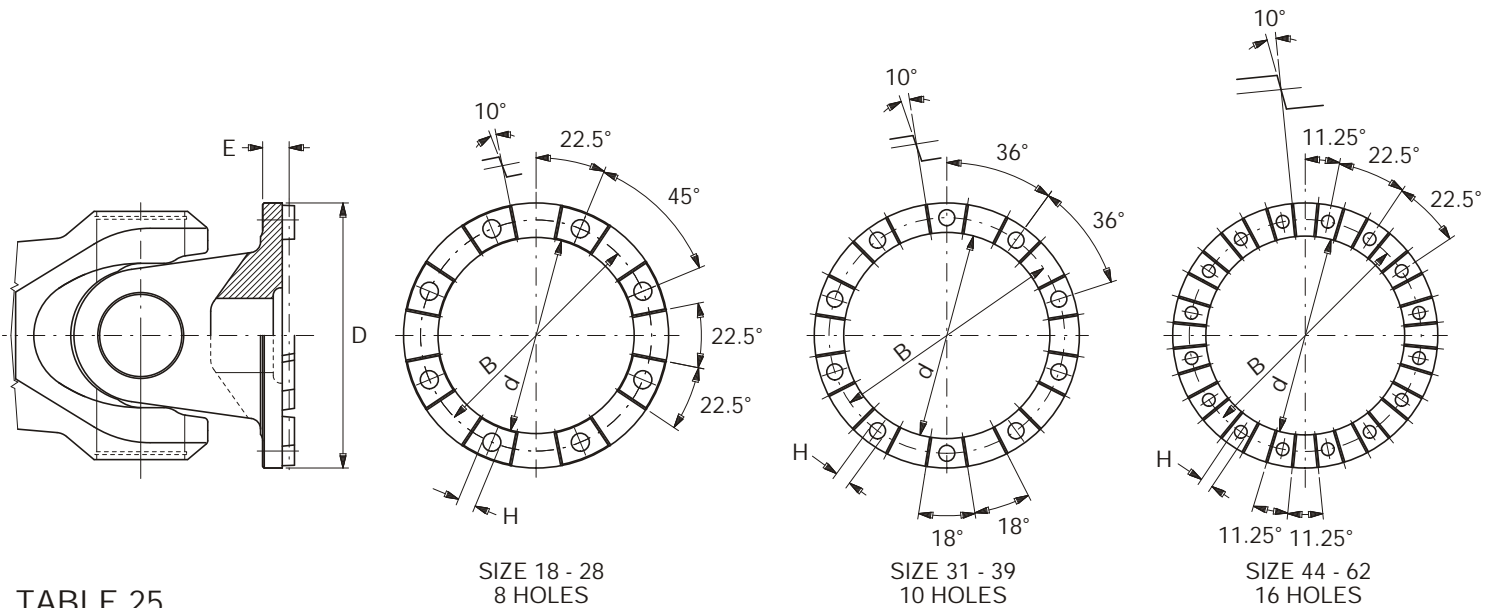

TABLE 25

| D | [mm] | 180 | 225 | 250 | 285 | 315 | 350 | 390 | 440 | 490 | 550 | 620 |
|-----|------|-------|-----|-----|-----|-----|-----|-----|-----|-----|-----|-----|
| d | [mm] | 130 | 165 | 185 | 205 | 245 | 270 | 300 | 330 | 360 | 430 | 490 |
| B ① | [mm] | 155.5 | 196 | 218 | 245 | 280 | 310 | 345 | 385 | 425 | 492 | 555 |
| H | [mm] | 13 | 15 | 17 | 17 | 19 | 19 | 21 | 21 | 23 | 23 | 25 |
| E | [mm] | 17 | 20 | 25 | 27 | 32 | 35 | 40 | 42 | 47 | 50 | 55 |
| z ② | | 8 | 8 | 8 | 8 | 10 | 10 | 10 | 16 | 16 | 16 | 16 |

① Tolerance ± 0.1 mm
② z = number of teeth

Different hole patterns may be checked for special applications.
Special applications with 4 dog - teeth available.

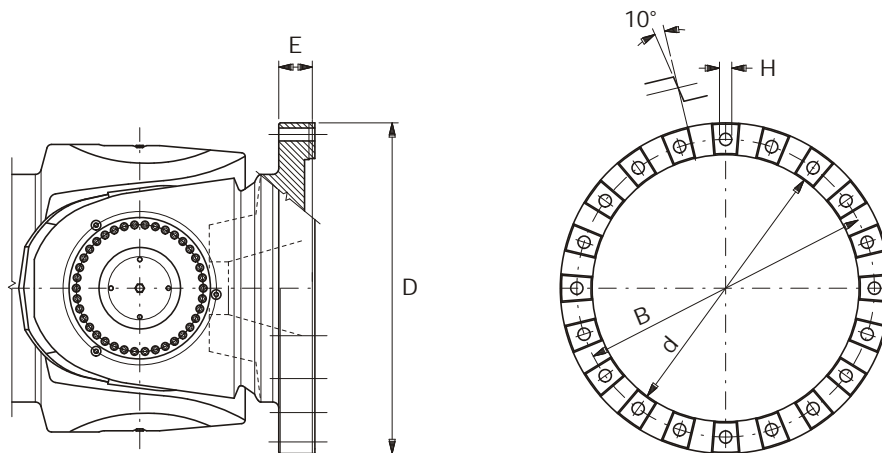

TABLE 26

| D | [mm] | 600 | 650 | 700 | 750 | 800 | 850 | 900 | 950 | 1000 | 1050 | 1100 | 1150 | 1200 | 1250 | 1300 |
|-----|------|-----|-----|-----|-----|-----|-----|-----|-----|------|------|------|------|------|------|------|
| d | [mm] | 480 | 520 | 570 | 610 | 650 | 680 | 710 | 760 | 800 | 840 | 880 | 925 | 960 | 1000 | 1040 |
| B ① | [mm] | 555 | 595 | 645 | 690 | 740 | 775 | 825 | 875 | 915 | 965 | 1015 | 1050 | 1100 | 1140 | 1190 |
| H | [mm] | 25 | 28 | 28 | 31 | 31 | 37 | 37 | 37 | 43 | 43 | 43 | 49 | 49 | 53 | 53 |
| i ② | | 30 | 30 | 34 | 30 | 34 | 30 | 32 | 34 | 32 | 34 | 32 | 30 | 32 | 30 | 32 |
| E | [mm] | 70 | 75 | 80 | 85 | 90 | 95 | 100 | 105 | 110 | 115 | 120 | 125 | 130 | 135 | 140 |
| z ③ | | 30 | 30 | 34 | 30 | 34 | 30 | 32 | 34 | 32 | 34 | 32 | 30 | 32 | 30 | 32 |

① Tolerance ± 0.1 mm
② i = number of holes
③ z = number of teeth

Different hole patterns may be checked for special applications.
Special applications with 4 dog - teeth available.

FLANGE BOLTING

ENGINEERING DATA

Hexagonal or cylindrical headed bolts in accordance to DIN 931 - 10.9 or 12.9, self locking nuts according to DIN 980 - 10 or 8.

The bolts are inserted from the companion flange side. With larger flanges it is possible to insert the bolts from the joint side.

With cylindrical companion flanges it is possible to use stud bolts

The bolts are to be tightened with a dynamometrical wrench, in accordance to the indicated torque. Maximum tightening torque must not exceed 90% of the elastic limit of the bolt material and must be applied to oiled bolts (friction factor 0.12).

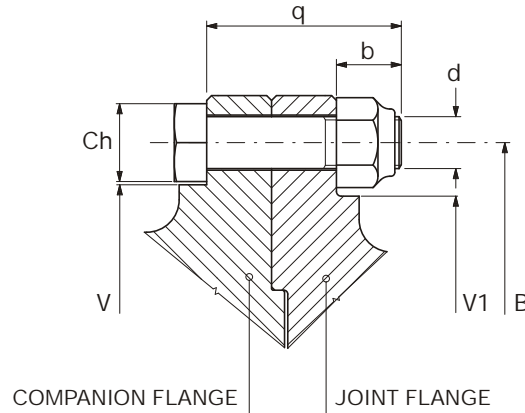

TABLE 27

| SIZE | | 18 | 22 | 25 | 28 | 31 | 35 | 39 | 44 | 49 | 55 | 62 |
|----------|------|-------|-------|-----|-------|-------|-------|-------|------|------|------|------|
| SERIES A | | | | | | | | | | | | |
| FLANGE | [mm] | 225 | 250 | 285 | 315 | 350 | 390 | 440 | | | | |
| B | [mm] | 196 | 218 | 245 | 280 | 310 | 345 | 385 | | | | |
| d | [mm] | M16 | M18 | M20 | M22 | M22 | M24 | M27 | | | | |
| q | [mm] | 50 | 60 | 70 | 75 | 80 | 100 | 100 | | | | |
| b | [mm] | 20 | 24 | 30 | 31 | 30 | 36 | 36 | | | | |
| V1 | [mm] | 150 | 160 | 190 | 220 | 250 | 280 | 310 | | | | |
| V | [mm] | 171 | 190 | 214 | 247 | 277 | 307 | 342 | | | | |
| Ch | [mm] | 24 | 27 | 30 | 32 | 32 | 36 | 41 | | | | |
| i | | 8 | 8 | 8 | 8 | 10 | 10 | 10 | | | | |
| Ma | [Nm] | 287 | 396 | 560 | 745 | 745 | 967 | 1415 | | | | |
| SERIES B | | | | | | | | | | | | |
| FLANGE | [mm] | 180 | 225 | 250 | 285 | 315 | 350 | 390 | 440 | 490 | 550 | 620 |
| B | [mm] | 155.5 | 196 | 218 | 245 | 280 | 310 | 345 | 385 | 425 | 492 | 555 |
| d | [mm] | M16 | M16 | M18 | M20 | M22 | M22 | M24 | M27 | M30 | M30 | M36 |
| q | [mm] | 55 | 60 | 75 | 80 | 100 | 100 | 110 | 120 | 130 | 140 | 160 |
| b | [mm] | 21 | 20 | 25 | 26 | 36 | 30 | 30 | 36 | 36 | 40 | 50 |
| V1 | [mm] | 114 | 152.5 | 173 | 189.5 | 228.5 | 259.5 | 288.5 | 304 | 329 | 412 | 460 |
| V | [mm] | 129.5 | 171 | 190 | 214 | 247 | 277 | 307 | 342 | 377 | 444 | 499 |
| Ch | [mm] | 24 | 24 | 27 | 30 | 32 | 32 | 36 | 41 | 46 | 46 | 55 |
| i | | 8 | 8 | 8 | 8 | 10 | 10 | 10 | 16 | 16 | 16 | 16 |
| Ma | [Nm] | 287 | 287 | 396 | 560 | 745 | 745 | 967 | 1415 | 1920 | 1920 | 3330 |
| SERIES C | | | | | | | | | | | | |
| FLANGE | [mm] | 225 | 250 | 285 | 315 | 350 | 390 | 440 | 490 | 550 | 600 | 680 |
| B | [mm] | 196 | 218 | 245 | 280 | 310 | 345 | 385 | 425 | 492 | 544 | 615 |
| d | [mm] | M16 | M18 | M20 | M22 | M22 | M24 | M27 | M30 | M30 | M33 | M36 |
| q | [mm] | 55 | 65 | 80 | 85 | 100 | 100 | 120 | 130 | 140 | 140 | 160 |
| b | [mm] | 21 | 25 | 30 | 31 | 36 | 30 | 40 | 46 | 46 | 40 | 50 |
| V1 | [mm] | 114 | 152.5 | 173 | 189.5 | 228.5 | 259.5 | 288.5 | 304 | 329 | 412 | 460 |
| V | [mm] | 171 | 190 | 214 | 247 | 277 | 307 | 342 | 377 | 444 | 492 | 599 |
| Ch | [mm] | 24 | 27 | 30 | 32 | 32 | 36 | 41 | 46 | 46 | 50 | 55 |
| i | | 8 | 8 | 8 | 10 | 10 | 10 | 16 | 16 | 16 | 16 | 16 |
| Ma | [Nm] | 287 | 396 | 560 | 745 | 745 | 967 | 1415 | 1920 | 1920 | 2600 | 3300 |

Ma = Tightening torque of flange bolts (10.9)

i = Number of bolts/holes per flange

UNIVERSAL SHAFTS SERIES A - B - C

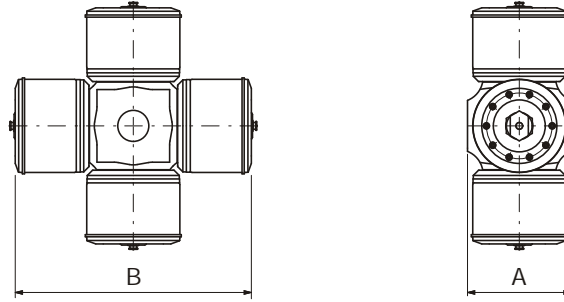

TABLE 28

| SIZE | | 18 | 22 | 25 | 28 | 31 | 35 | 39 | 44 | 49 | 55 | 62 |
|------|------|-----|-----|-----|-----|------|-----|-----|-----|-----|-----|-----|
| A | [mm] | 53 | 64 | 70 | 78 | 90 | 100 | 125 | 145 | 165 | 185 | 205 |
| B | [mm] | 151 | 197 | 220 | 250 | 275 | 302 | 341 | 418 | 464 | 522 | 590 |
| W | [kg] | 4.5 | 7.5 | 12 | 18 | 26.5 | 40 | 56 | 85 | 122 | 160 | 260 |

UNIVERSAL SHAFTS SERIES D - G - F - J

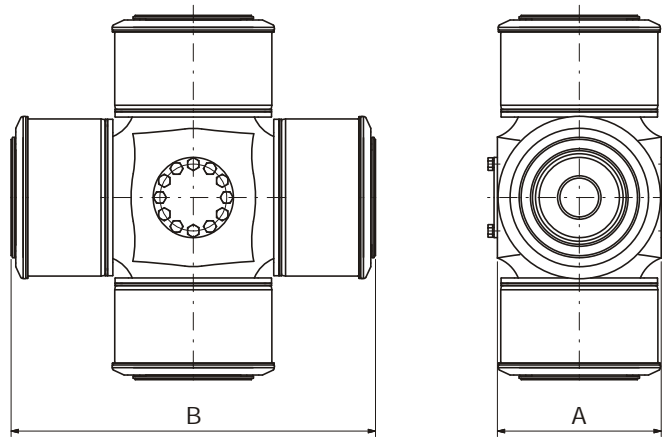

TABLE 29

| SIZE | | 60 | 65 | 70 | 75 | 80 | 85 | 90 | 95 | 100 | 105 | 110 | 115 | 120 | 125 |
|------|------|-----|-----|-----|-----|-----|-----|-----|-----|------|------|------|------|------|------|
| A | [mm] | 245 | 260 | 285 | 300 | 325 | 340 | 360 | 375 | 400 | 420 | 440 | 460 | 480 | 500 |
| B | [mm] | 545 | 590 | 635 | 680 | 726 | 770 | 815 | 862 | 908 | 953 | 998 | 1044 | 1090 | 1135 |
| W | [kg] | 240 | 305 | 380 | 470 | 570 | 680 | 810 | 950 | 1110 | 1280 | 1480 | 1690 | 1920 | 2170 |

UNIVERSAL SHAFTS SERIES E - H

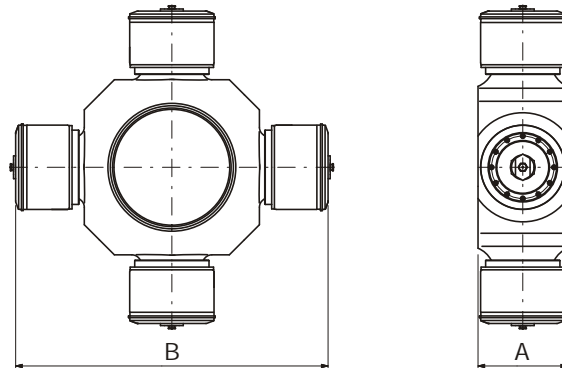

TABLE 30

| SIZE | | 18 | 22 | 25 | 28 | 31 | 35 | 39 | 44 | 49 | 55 |
|------|------|-------|-------|-------|-----|-----|-----|------|-----|-------|-------|
| A | [mm] | 50 | 60 | 70 | 80 | 90 | 100 | 110 | 135 | 150 | 165 |
| B | [mm] | 225.5 | 285.5 | 306.5 | 360 | 400 | 440 | 472 | 551 | 628.5 | 685.5 |
| W | [kg] | 6 | 14 | 16 | 24 | 30 | 48 | 81.5 | 91 | 146 | 173 |

W = Weight in [kg]
Journal cross supplied as complete unit only

For identification see page 48
For lubrication see page 46

DESIGN VARIATIONS

BEARING TYPES

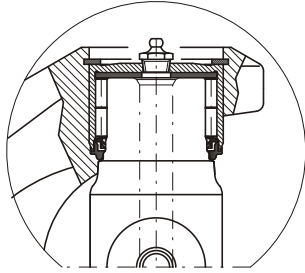

SUITABLE FOR SIZE < 44

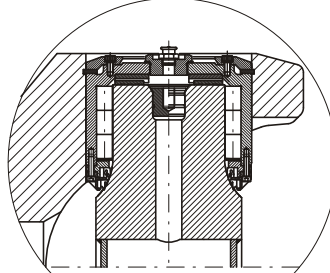

SUITABLE FOR SIZE ≥ 44

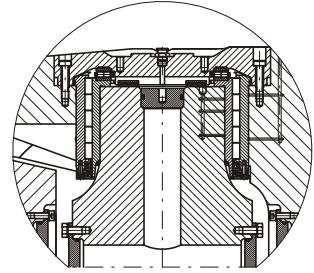

FOR HEAVY DUTY
SUITABLE FOR SIZE ≥ 60

SEAL TYPE

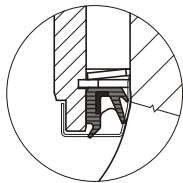

SIZES 18 ÷ 39

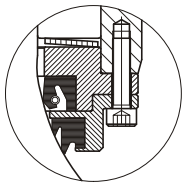

SIZES 44 ÷ 62

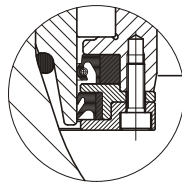

SIZES ≥ 60

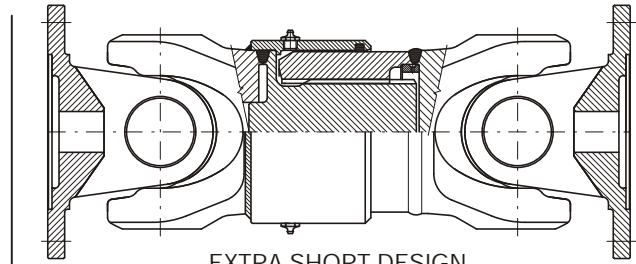

EXTRA SHORT DESIGN

OUTER CENTERING RING

INNER CENTERING RING

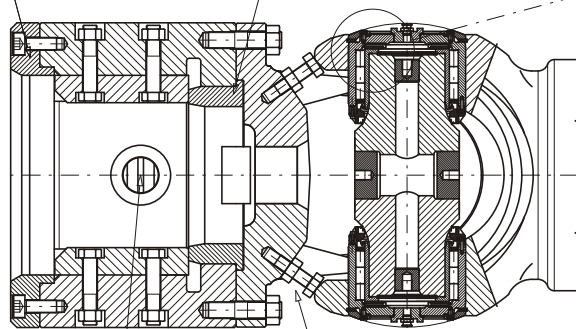

ROLL DETENT ASSEMBLY

ANGLE LIMITERS

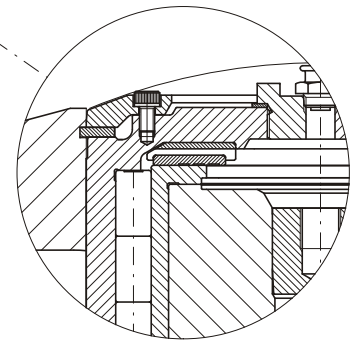

BEARING WITH SPECIAL THRUST DEVICE
AND WITH INNER RING

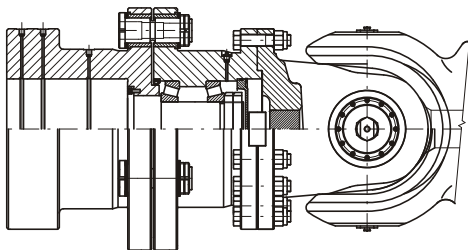

SHEAR PIN SAFETY DEVICE

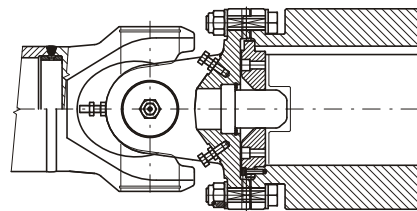

QUICK ENGAGEMENT

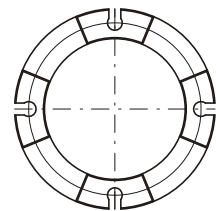

LOCKING DEVICE

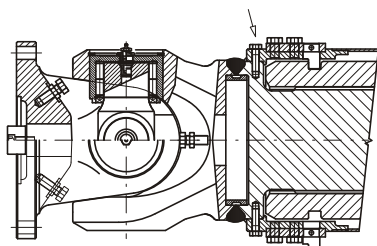

SPECIAL WELD FLANGE

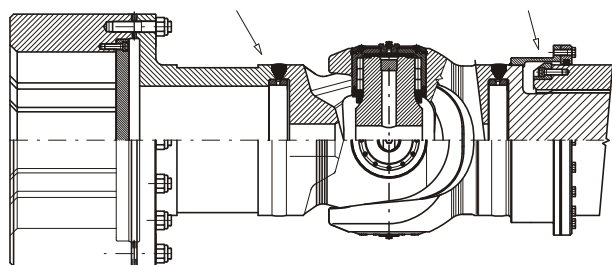

EXTRA SLIDING DETENT DEVICE

DESIGN VARIATIONS

EXTRA SLIDING DETENT DEVICE GUIDING BUSHES PROTECTION / ANGLE LIMITER / SPINDLE SUPPORT

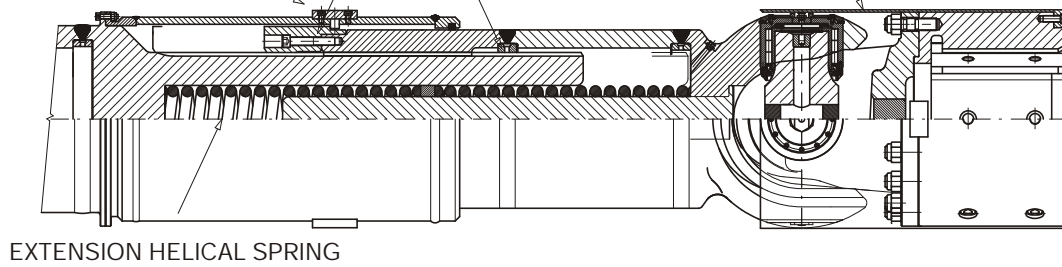

UNIVERSAL SHAFT FOR CONTINUOUS CASTING

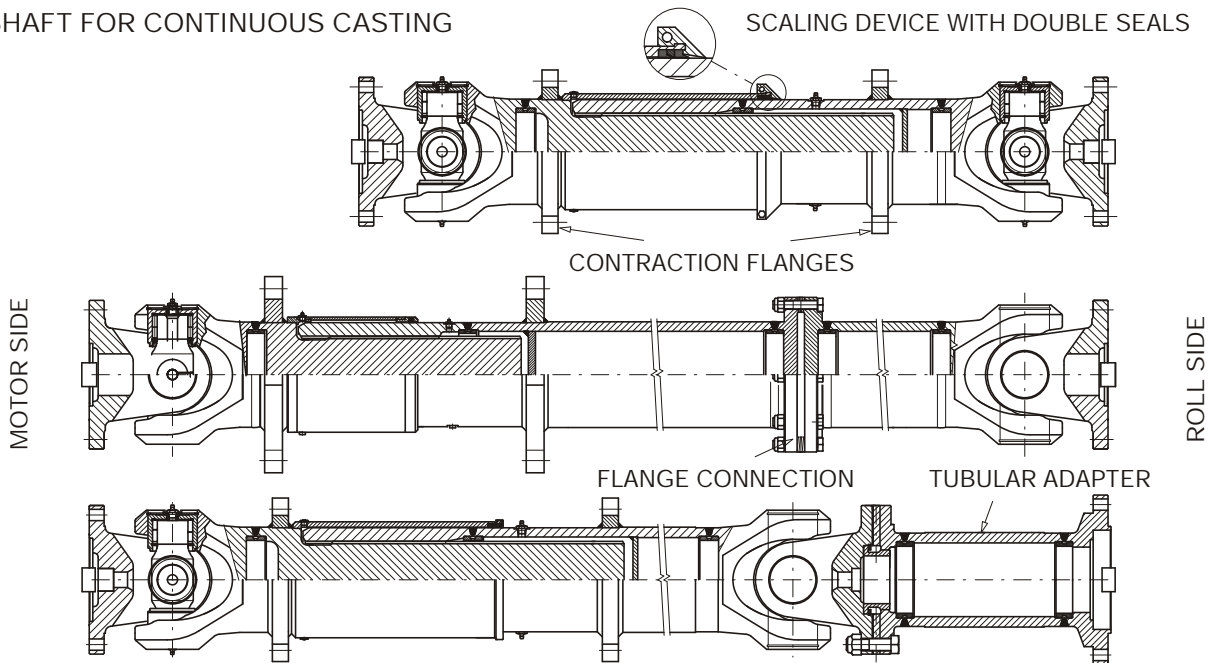

HEAVY AND EXTRA HEAVY UNIVERSAL SHAFTS FOR ROLLING MILL

EDGER MILL DESIGN

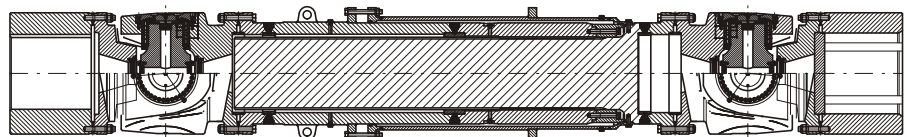

HIGH TORSIONAL STIFFNESS DESIGN

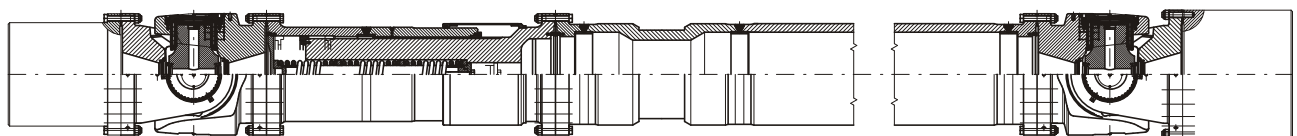
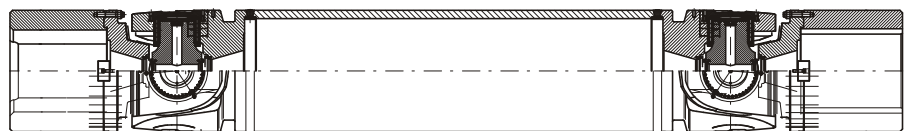

DESIGN WITH SPINDLE CARRIER AND TWO-HALF ROLLER BEARING OR BUSHING

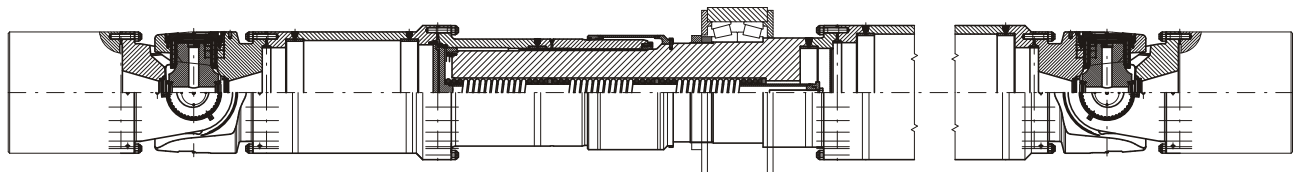

DESIGN WITH SPINDLE CARRIER AND TAPER ROLLER BEARINGS

OPERATING PRINCIPLES

REQUIREMENTS FOR ANGULAR POSITIONING

Universal shafts have the peculiarity to transmit drive between two shafts being either parallel and misaligned (Z arrangement) or incidental (W arrangement), maintaining the rotating speed of the driven shaft promptly equal to that of the driving shaft, provided the following geometrical conditions are met:

- same deflection angle in both joints ($\beta_1 = \beta_2$)
- the inner yoke axis of both joints shall be on the same level
- both the drive shaft and the driven shaft shall also be on the same level.

In case of space misalignment over different levels, but providing identical combinations (Z/Z or W/W) and identical angles, uniformity is guaranteed.

For high speed transmissions, the equality of β_1 and β_2 angles should be checked, in order to limit the difference to $1^\circ \div 1.5^\circ$ max ($n > 300$ rpm).

More important differences ($2^\circ \div 3^\circ$) may be accepted in case of slow speed transmissions only ($n < 300$ rpm).

RESULTING ANGLE

In case of misalignment over several levels, both the horizontal and the vertical angles should be taken into consideration to determine the angulation.

h = angle on the horizontal plane

v = angle on the vertical plane

$$\tan \beta = \sqrt{\tan^2 h + \tan^2 v}$$

CALCULATING THE MAXIMUM ANGLE

In order to obtain a silent transmission, centrifugal forces in the central section shall not be allowed to rise over a given limit.

Centrifugal forces depend on the moment of inertia of the central section of the universal shaft and on the product of the number of revolutions by the deflection angle.

n = max number of revolution in operation

β = max angulation

See table 37 page 40.

MAXIMUM SPEEDS

In order to achieve silent and vibrationless operating conditions, make sure that the rotating speed is lower than the maximum permissible speed set as a critical bending limit as well as a dynamical limit mentioned earlier.

For critical bending speed refer to table 36 page 39.

For dynamical speed refer to table 37 page 40.

LOADS ON THE BEARINGS

While designing the size of a universal shaft, it is important to remember that certain operating conditions involve axial and radial forces. Such forces must be supported by the shaft bearings of the machines which are drivingly connected by means of the universal shafts.

- Axial Forces

The axial forces occur during the length variations of the universal shaft under load.

Such forces increase as the torque increases.

$$F_a = Td \frac{\mu}{r_m} \cos \beta$$

F_a = axial force

Td = torque

r_m = average radius of the splined profile

μ = friction coefficient. It depends on surface roughness and hardness. Tabulated values $0.11 \div 0.15$ for steel against lubricated steel

β = angulation

- Radial Forces

Torque transmission by means of a universal shaft causes bending moments to occur at the shafts, generating radial forces which are therefore proportional to the torque and the deflection angle. These forces are not constant: they vary periodically following a sinusoidal curve, twice every revolution of the universal shaft.

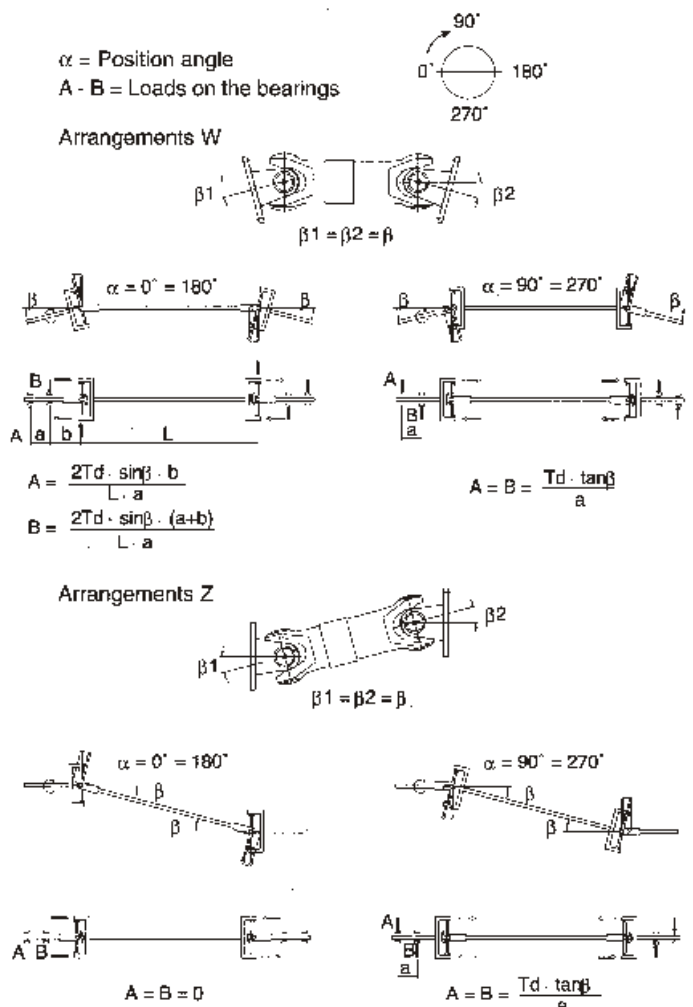

RATING CHARACTERISTICS OF UNIVERSAL SHAFTS

- M_k** = Rating designed torque (kNm)
It corresponds to the maximum allowable, static constant torque. Only unfrequent, minor load peaks are admitted.
- M_{dW}** = Alternating torque (kNm)
It corresponds to the fatigue maximum limit torque for a shaft subject to alternating load min/ max - 1 ÷ 0 (stress σ_{-1} per 2 10⁶ cycles).
- M_{bSch}** = Pulsating torque (kNm)
It corresponds to the fatigue maximum limit torque for a shaft subject to a pulsating load min/ max 0 ÷ 1 (stress σ_{D-1} per 2 10⁶ cycles).
- M_{cS}** = Limit torque = 1.3 MK (kNm)
It corresponds to the maximum static torque provided by the maximum permissible elastic limit, and it shall never be overcome. Such a stress level may only be reached just 5 times/h for 0.5 ÷ 1 sec.

OPERATING PARAMETERS

- N** = Maximum motor or brake absorbed power (kW).
If absorbed power or calculating data are missing, consider the motor rated load multiplied by absorption percentage (0,75 ÷ 2,25)
- n** = Rated rotation speed of universal shaft (rpm).
- K_s** = Overload factor.
Such factor, considering: inertia and connection times - possible jammings - maximum short circuits - electric motor absorption, shall assess the existing ratio between the rating torque and the maximum or occasional torque. An indication of possible readings should be looked for within the 1.25 ÷ 10 range.
For rolling mills the T.A.F. (Torque Amplification Factor) value should be considered (1,3 ÷ 2).
- Z** = Distribution factor.
Such factor is supposed to take into consideration the different torque distribution over several outputs controlled by just one generator.
Some tabulated examples are provided, as follows:
Two driven work roll stands = 0.5 ÷ 0.66
Three driven work roll stands = 0.66 ÷ 0.75
Roll flatteners = 0.75 ÷ 1
Feeding rolls = 1
Pinch rolls = 0.5 ÷ 0.75
Rubber mixers = 0.5 ÷ 0.66
For single drives, always consider = 1

LOAD DATA

- Absorbed torque $T_d = \frac{N}{n} Z 9.6$ (kNm)
- Maximum torque $T_{max} = T_d K_s$ (kNm)

SERVICE AND LIFE FACTORS

TABLE 31

| Service factors SF | | | |
|---------------------------|---------------|------|-----|
| Load type | Type of drive | | |
| | U | M | H |
| Constant torque CT | 1.1 | 1.25 | 1.5 |
| With light shocks LS | 1.5 | 1.75 | 2 |
| With medium shocks MS | 2 | 2.5 | 3 |
| With high shocks HS | 3 | 4 | 5 |
| With very high shocks VHS | 5 | 7.5 | 10 |

- Type of drive

- U** = On-going drive with low pickup torques and without reversals and/or throbs. Drives from turbines, DC motors, hydraulic motors.
- M** = On-going drive with medium pickup torques and with occasional reversals and/or low throbs. Drives from AC motors, DC motors, multi-cylinder endothermic motors.
- H** = Drive with reversal, high pickup torques and/or important throbs. Drive from AC motors, DC motors, single-cylinder endothermic motors.

- Type of drive equipment

- CT** = Electric current generators having a constant load, centrifugal pumps, conveyer belts, machine tools, wood processing equipment, medium-power fans, fluid product stirrers, heavy-duty machine tools.
- LS** = Multi-cylinder reciprocating pumps and compressors, large-power fans, edge and light section rolling mills, machine tools, viscous product stirrers, locomotives.
- MS** = Rolling mills for long products, tube rolling mills, paper milling machines, rubber calenders, flatteners, hoisting operations, transverse traverses and slippages.
- HS** = Pump and single-cylinder compressors, presses, one-way roll tables, one-way roughing mills, taking up rolls for winding reels, rotating drills, heavy-duty excavators, mixers, grinders, bending machines, locomotives, rubber stirrers, hoisting operations, transverse traverses and slippages.
- VHS** = Reversing roughing mills, reversing roll tables, scale breakers, winding reels, reciprocating shears.

TABLE 32

| Life factors KL | | | | |
|---------------------------|------|------|------|------|
| Deflection angle | 3° | 5° | 10° | 15° |
| General services | 1 | 1.15 | 1.25 | 1.4 |
| light | 1.15 | 1.25 | 1.4 | 1.55 |
| moderate | 1.25 | 1.4 | 1.55 | 1.75 |
| Industrial services heavy | | 1.4 | 1.55 | 1.75 |
| very heavy | 1.55 | 1.75 | 1.95 | 2.20 |
| continuous heavy duty | 1.75 | 1.95 | 2.20 | 2.45 |

Readings in tables 31 and 32 are given as a simple indication and should not be taken as binding: their interpolation is allowed.

SIZE SELECTION

SELECTION BASED UPON THE LOAD CAPACITY

Selection of the correct size of universal shaft will prove adequate if the following requirements are fully met:

$$T_d \times SF = T_k < M_k$$

$$T_d \times K_L = T_D < M_{Dw} \text{ for alternating torque drives}$$

$$< M_{DSch} \text{ for pulsating torque drives}$$

$$T_{max} < M_{cs} \text{ for } t = 0,5 \div 1 \text{ sec.}$$

$$T_{max} < M_k \text{ for } t > 1 \text{ sec.}$$

SELECTION BASED ON BEARING LIFE

Selection of the correct size of universal shaft will prove adequate, if the calculated theoretical life of the bearings matches the required life.

Calculation methods, illustrated below, are based on the specifications of ISO 281 standards. Usually, the average life of bearings is approx 4 times longer than the calculated theoretical life. When it comes to drives characterized by important torque and/or rotating speed variations, in order not to oversize the universal shaft, the average torque and/or the average speed should be used to calculate the bearing life. In case the deflection angle is smaller than 3°, as the bearing oscillations are not important, no life dynamic test will be required. Only the static condition shall be checked, which will be deemed properly verified if meeting the following requirements:

$$T_{max} < M_{cs} \text{ or } M_k$$

- Average torque

| Stage of process | 1 | 2 | 3... n |
|------------------|-------|-------|-----------------|
| Speed (rpm) | n_1 | n_2 | $n_3 \dots n_n$ |
| Torque (kNm) | T_1 | T_2 | $T_3 \dots T_n$ |
| Time ratio (%) | t_1 | t_2 | $t_3 \dots t_n$ |

The cubed average torque and the average speed will be:

$$T_{dA} = \sqrt[3]{\frac{\sum (T_1^3 n_1 t_1 + \dots + T_n^3 n_n t_n)}{\sum (n_1 t_1 + \dots + n_n t_n)}}$$

$$n_A = \frac{\sum (n_1 t_1 + \dots + n_n t_n)}{\sum (t_1 + \dots + t_n)}$$

- Life check

L_{Rh} = required life (h)

L_{Ch} = calculated theoretical life (h)

n_A = average rotating speed (rpm)

A = average working angle (°)

T_{dA} = average working torque (kNm)

C = life constant (kNm)

R = life reduction factor ($R = a \times b$)

a = operation factor, it depends on the drive type

b = lubrication factor; it depends on the load type

TABLE 33

| DRIVING MACHINE | ELECTRIC MOTOR | MULTI-CYLINDER COMBUSTION ENGINE |
|-----------------|----------------|----------------------------------|
| a | 1 | 0.8 |

In case of elastic or hydraulic coupling, $a = 1$ in any case.

TABLE 34

| LOAD TYPE | UNIFORM | PULSATING | ALTERNATING |
|-----------|---------|-----------|-------------|
| b | 1 | 0.85 | 0.6 |

- Data:

T_{dA} = average working torque (kNm)

n_A = average rotating speed (rpm)

C = life constant, function of the size of the universal shaft selected and the working angle Table 35 page 38 (kNm)

A = average working angle (°)

$$L_{Ch} = \frac{1.5 \cdot 10^7}{n_A \cdot T_{dA}^{10/3}} \cdot C \cdot R = (h)$$

The following outcome shall be achieved:

$$L_{Ch} \sim L_{Rh}$$

If not, switch to the next bigger size and repeat the check.

SPECIAL SELECTIONS

- For high speed universal shafts having high deflection angle check that:

$$n_{max} < n$$

- For high speed universal shafts having long lengths check that:

$$n_{max} < 0.8 n_c$$

- For universal shafts driving horizontal displacements on rails, i.e.: crane transverse traverses or locomotive drives, check that:

$$T_{slip} < M_{Dw}$$

$$T_{slip} = \frac{G \cdot 9.81 \cdot \mu \cdot D \cdot N^\circ}{2000} = \text{kNm}$$

where:

G = load on the wheel (kg)

μ = friction factor 0.14 to 0.25

D = wheel diameter (m)

N° = number of driven wheels

- For universal shafts driving paper mill rolls or plate stretching roll check that:

$$K > K_u$$

$$K_u = \frac{(f_n \cdot 2)^2 \cdot J_1 \cdot J_2}{(J_1 + J_2)} = \text{Nm/rad}$$

where:

K = torsional stiffness of the universal shaft, to be requested to MAINA Technical Dept. (Nm/rad)

K_u = required torsional stiffness (Nm/rad)

f_n = required frequency > 10 to 25 HZ. It is calculated for the response times of the speed adjustments of CD motors < 1 sec.

J_1 = moments of inertia from the universal shaft to the motor (kgm^2)

J_2 = moments of inertia from the universal shaft to the rolls (kgm^2)

SELECTION EXAMPLES

I- Telescopic universal shaft for connection of a reduction gear with the first stand of a 3-high billet roughing mill.
16 hours of operation per day.

- Selection data:

- Driven by a DC electric motor along with a flywheel on the drive shaft ($PD^2 = 2700 \text{ kgm}^2$)
- Very heavy duty industrial service
- Pulsating load with considerable shocks
- Safety high speed coupling with pre-selected shear pins set at 4 times the motor rating torque
- Motor rated load $N = 1200 \text{ kW}$
- Motor rated rotating speed $n_1 = 960 \text{ rpm}$
- Reduction gear ratio $R = 1/8$

$$\text{Rotating speed of universal shaft } n = \frac{n_1}{R} = \frac{960}{8} = 120 \text{ rpm}$$

- Life requirement $> 25000 \text{ h}$
- Deflection angle 1°
- Minimum distance between centres: 445 mm
- Min. length 1310 mm , max. length 1360 mm , length compensation 50 mm

- Selecting the universal shaft

Overload factor $K_s = 5$

Load distribution factor $Z = 0.7$

Service factor $SF = 4$

Life factor $K_L = 1.4$

$$T_d = \frac{1200}{120} \cdot 0.7 \cdot 9.6 = 67 \text{ kNm}$$

$$T_{\max} = 67 \cdot 5 = 335 \text{ kNm}$$

Based upon the Table 2 of page 7 it is possible to select a universal shaft BB 39 having a flange diameter of 390 mm , a min. length of 1350 mm , a max. length of a 1420 mm and a length compensation of 70 mm .

$$M_k = 302 \text{ kNm}$$

$$M_{BSch} = 224 \text{ kNm}$$

$$M_{CS} = M_k \cdot 1.3 = 392.6 \text{ kNm}$$

$$T_k = T_d \cdot SF = 67 \cdot 4 = 268 \text{ kNm} = M_k$$

$$T_D = T_d \cdot K_L = 67 \cdot 1.4 = 94 \text{ kNm} < M_{BSch}$$

$$T_{\max} = 335 \text{ kNm} < M_{CS}$$

In this case the bearing life check would be left out, as the deflection angle is $< 3^\circ$.

II - Fix universal shaft for connection of a reduction gear with a 2-high reversing cold mill.
24 hours of operation per day.

- Selection data:

- Driven by a DC electric motor
- Very heavy duty industrial service
- Pulsating load with shocks and reversals
- Safety high speed coupling with quick-release device, set at 2.5 times the motor rating torque
- Motor rated load $N = 2600 \text{ kW}$
- Motor rated rotating speed $n_1 = 960 \text{ rpm}$
- Reduction gear ratio $R = 1/1.28$

$$\text{Rotating speed of universal shafts } n = \frac{n_1}{R} = \frac{960}{1.28} = 750 \text{ rpm}$$

- Life requirement $> 10000 \text{ h} = L_{Rh}$
- Deflection angle 4°
- Minimum distance between centres: 355 mm
- Flange-to-flange distance 2000 mm
- Compensating axial movement along the roll neck

- Selecting the universal shaft

Overload factor $K_s = 3$

Load distribution factor $Z = 0.66$

Service factor $SF = 5$

Life factor $K_L = 1.4$

$$T_d = \frac{2600}{750} \cdot 0.66 \cdot 9.6 = 22 \text{ kNm}$$

$$T_{\max} = 22 \cdot 3 = 66 \text{ kNm}$$

Based upon the table 3 of page 9 it is possible to select a universal shaft BC 31 having a flange diameter of 350 mm , a special length $L_f = 2000 \text{ mm}$ - dynamically balanced.

$$M_k = 167 \text{ kNm}$$

$$M_{DW} = 76 \text{ kNm}$$

$$M_{CS} = M_k \cdot 1.3 = 217.1 \text{ kNm}$$

$$T_k = T_d \cdot SF = 22 \cdot 5 = 110 \text{ kNm} < M_k$$

$$T_D = T_d \cdot K_L = 22 \cdot 1.4 = 31 \text{ kNm} < M_{DW}$$

$$T_{\max} = 66 \text{ kNm} < M_{CS}$$

From page 36 table 33 and 34, the coefficients

$a = 1$ $b = 0.60$ $R = a$ $b = 0.6$ can be obtained.

From page 38 table 35, the life constant $C = 55000 \text{ kNm}$ can be obtained

$$T_{dA} = T_d; n_A = n.$$

The calculated theoretical life will be:

$$L_{ch} = \frac{1.5 \cdot 10^7}{n_A \cdot T_{dA}^{100}} \cdot C \cdot R = \frac{1.5 \cdot 10^7 \cdot 55000 \cdot 0.6}{750 \cdot 22^{100}} = 22000 \text{ h}$$

$$L_{ch} = L_{Rh} \text{ as requested}$$

In this case, one will be able to rely on average life expectancies $\geq 88000 \text{ hrs}$.

SIZE SELECTION

Table 35 shows the life constant of universal shafts as a function of working angle.

TABLE 35

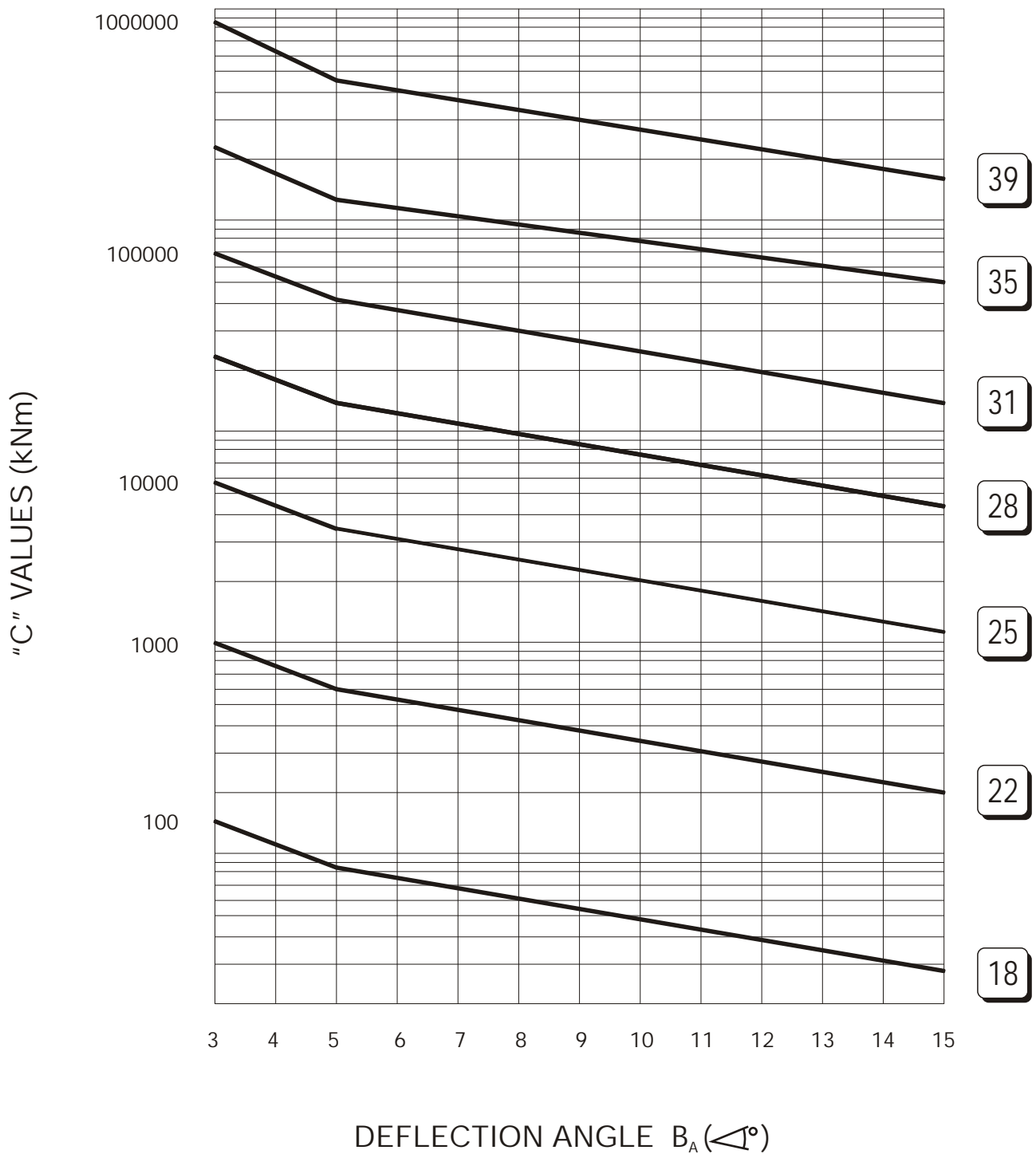

After choosing the type and size of universal shaft based upon its application, its performance and its life, it is necessary to ensure that the maximum rotational speed is less than 80% of the first critical bending speed.

$$n_{\max} < 0.8 n_c$$

TABLE 36

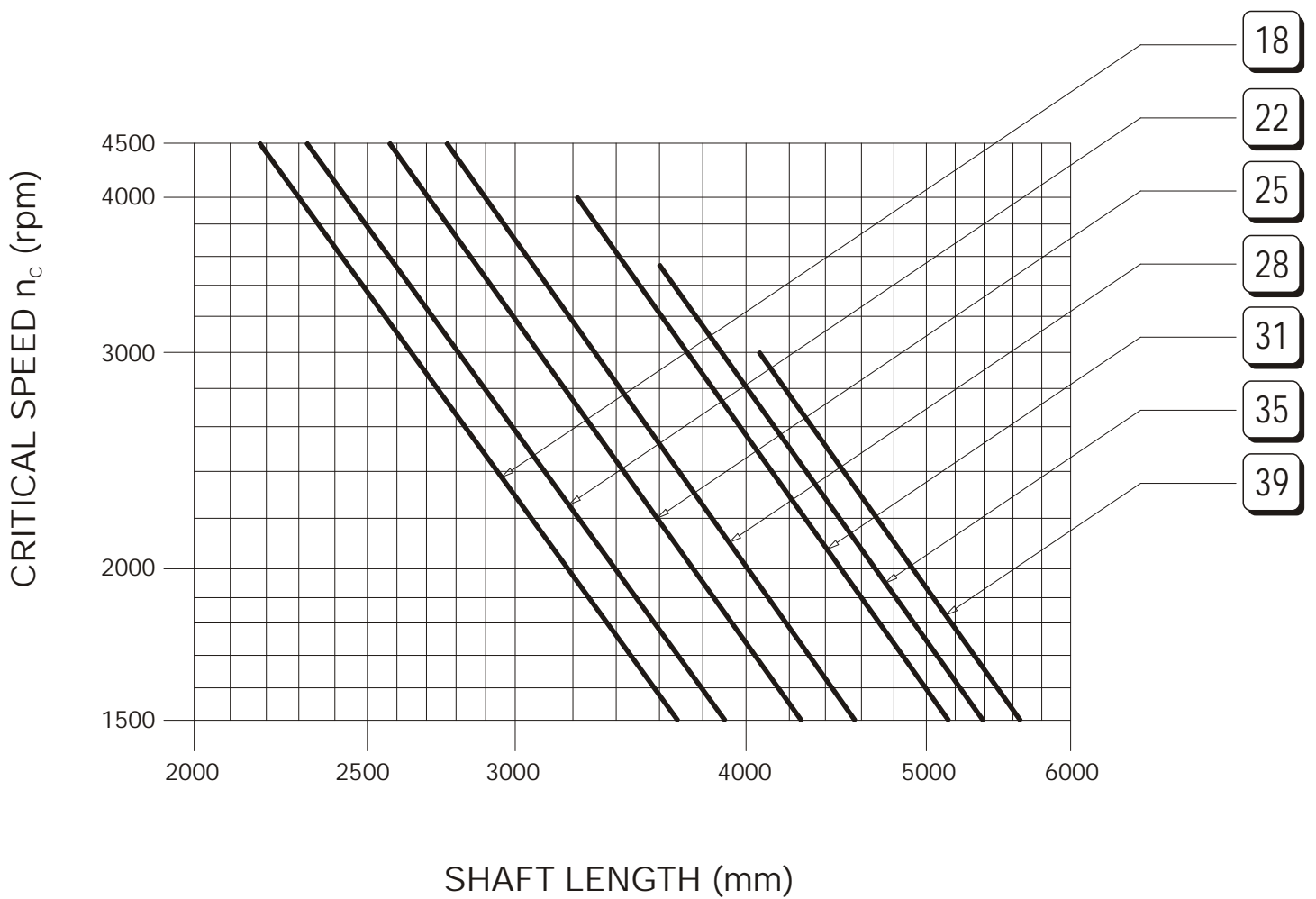

SIZE SELECTION

Table 37 shows the maximum allowable speed values as a function of the working angle and the size of the universal shaft. In fact as previously stated at page 34, the intermediate shaft is subject to periodical variations of its angular speed and therefore to inertial torques increasing proportionally to the square of both the working angle and angular speed.

TABLE 37

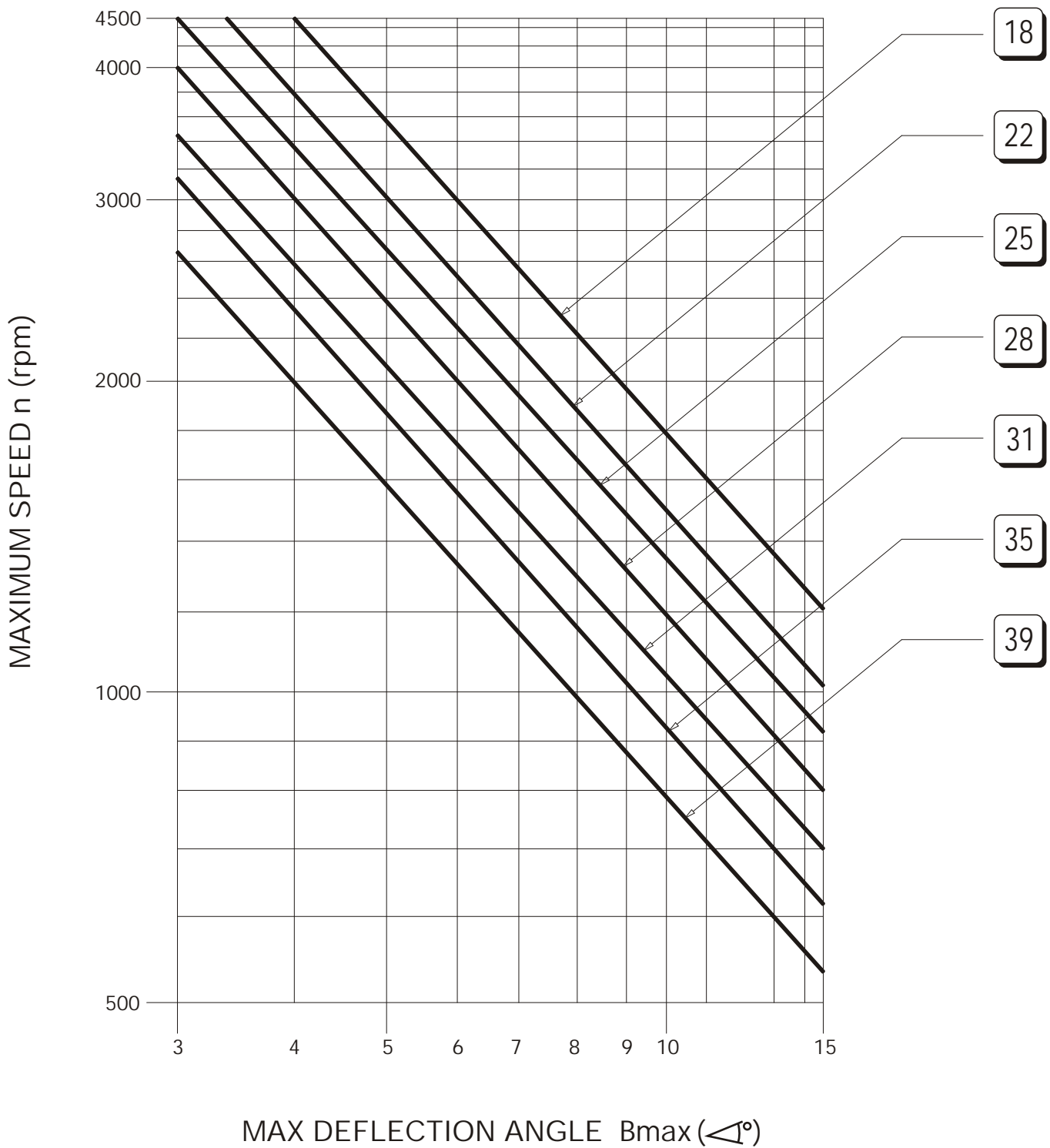

ENGINEERING DATA

WEIGHTS

G min = weight in [kg] at Lz min and La min or Lf

G La = weight in [kg] for 100 mm length compensation La

G Lz or G Lf = weight in [kg] for 100 mm tube

TABLE 38

| SIZE | | 18 | 22 | 25 | 28 | 31 | 35 | 39 |
|------|-------|-----|-----|-----|------|------|------|------|
| TYPE | | | | | | | | |
| AA | Lz | 795 | 855 | 985 | 1080 | 1235 | 1350 | 1495 |
| | La | 140 | 145 | 150 | 155 | 160 | 170 | 180 |
| | G min | 80 | 123 | 185 | 270 | 415 | 555 | 785 |
| | G Lz | 4.4 | 4.8 | 6.4 | 8.0 | 14.1 | 25.5 | 28.1 |
| | G La | 4.3 | 6.9 | 9.5 | 11.4 | 17.9 | 20.1 | 25.6 |
| AB | G | 62 | 101 | 151 | 228 | 351 | 478 | 714 |
| AC | Lf | 495 | 535 | 615 | 695 | 780 | 835 | 930 |
| | G min | 47 | 78 | 112 | 171 | 244 | 331 | 478 |
| | G Lf | 4.4 | 4.8 | 6.4 | 8.0 | 14.1 | 25.5 | 28.1 |
| AD | G | 44 | 75 | 109 | 166 | 233 | 318 | 455 |

| SIZE | | 18 | 22 | 25 | 28 | 31 | 35 | 39 | 44 | 49 | 55 | 62 |
|------|-------|-----|-----|-----|------|------|------|------|------|------|------|------|
| TYPE | | | | | | | | | | | | |
| BA | Lz | 795 | 855 | 985 | 1080 | 1235 | 1350 | 1495 | 1680 | 1760 | 1965 | 2250 |
| | La | 140 | 145 | 150 | 155 | 160 | 170 | 180 | 190 | 200 | 210 | 230 |
| | G min | 81 | 125 | 189 | 276 | 421 | 564 | 800 | 1132 | 1442 | 2039 | 3025 |
| | G Lz | 4.4 | 4.8 | 6.4 | 8.0 | 14.1 | 25.5 | 28.1 | 27.7 | 32.4 | 45.6 | 39.7 |
| | G La | 4.3 | 6.9 | 9.5 | 11.4 | 17.9 | 20.1 | 25.6 | 27.2 | 35.6 | 45.6 | 60.0 |
| BB | G | 63 | 103 | 155 | 234 | 357 | 487 | 729 | 992 | 1263 | 1782 | 2640 |
| BC | Lf | 495 | 535 | 615 | 695 | 780 | 835 | 930 | 1140 | 1205 | 1355 | 1530 |
| | G min | 48 | 80 | 116 | 176 | 250 | 340 | 493 | 722 | 942 | 1331 | 2130 |
| | G Lf | 4.4 | 4.8 | 6.4 | 8.0 | 14.1 | 25.5 | 28.1 | 27.7 | 32.4 | 45.6 | 39.7 |
| BD | G | 45 | 77 | 113 | 171 | 239 | 327 | 470 | 694 | 901 | 1269 | 2050 |

| SIZE | | 18 | 22 | 25 | 28 | 31 | 35 | 39 | 44 | 49 | 55 | 62 |
|------|-------|-----|-----|-----|------|------|------|------|------|------|------|------|
| TYPE | | | | | | | | | | | | |
| CA | Lz | 795 | 855 | 985 | 1080 | 1235 | 1350 | 1495 | 1680 | 1760 | 1965 | 2250 |
| | La | 140 | 145 | 150 | 155 | 160 | 170 | 180 | 190 | 200 | 210 | 230 |
| | G min | 84 | 127 | 193 | 280 | 427 | 572 | 812 | 1139 | 1456 | 2059 | 3065 |
| | G Lz | 4.4 | 4.8 | 6.4 | 8.0 | 14.1 | 25.5 | 28.1 | 27.7 | 32.4 | 45.6 | 39.7 |
| | G La | 4.3 | 6.9 | 9.5 | 11.4 | 17.9 | 20.1 | 25.6 | 27.2 | 35.6 | 45.6 | 60.0 |
| CB | G | 66 | 105 | 159 | 238 | 363 | 495 | 741 | 999 | 1277 | 1802 | 2680 |
| CC | Lf | 495 | 535 | 615 | 695 | 780 | 835 | 930 | 1140 | 1205 | 1355 | 1530 |
| | G min | 51 | 82 | 120 | 180 | 256 | 348 | 505 | 729 | 956 | 1351 | 2170 |
| | G Lf | 4.4 | 4.8 | 6.4 | 8.0 | 14.1 | 25.5 | 28.1 | 27.7 | 32.4 | 45.6 | 39.7 |
| CD | G | 48 | 79 | 117 | 175 | 245 | 335 | 482 | 701 | 915 | 1289 | 2090 |

EXAMPLE: BA25 Lz' = 1300 La' = 250

$$m = G \text{ min} + G \text{ Lz} \frac{(Lz' - Lz)}{100} + G \text{ La} \frac{(La' - La)}{100} = 189 + 6.4 \frac{(1300 - 985)}{100} + 9.5 \frac{(250 - 150)}{100} = 219 \text{ Kg}$$

ENGINEERING DATA

GREASE QUANTITIES

Q min = quantity of grease in [Kg] at Lz min and La min for length compensator

Q bearing = quantity of grease in [Kg] for 8 bearings

Q La = quantity of grease in [Kg] for 100 mm length compensation La

Q min, Q La, Q bearing are quantities of reference

| SIZE | | 18 | 22 | 25 | 28 | 31 | 35 | 39 | 44 | 49 | 55 | 62 |
|-----------|-----------|------|------|------|------|------|------|------|------|------|------|------|
| TYPE | | | | | | | | | | | | |
| AA BA CA | La | 140 | 145 | 150 | 155 | 160 | 170 | 180 | 190 | 200 | 210 | 230 |
| | Q min | 0.9 | 0.7 | 1.1 | 1.4 | 2.7 | 3.7 | 8.2 | 10.7 | 7.1 | 17.0 | 20.0 |
| | Q La | 0.35 | 0.30 | 0.40 | 0.75 | 0.70 | 1.00 | 1.20 | 2.65 | 1.95 | 2.05 | 2.50 |
| ALL TYPES | Q bearing | 0.05 | 0.07 | 0.16 | 0.28 | 0.40 | 0.68 | 0.92 | 1.40 | 1.85 | 2.40 | 3.50 |

EXAMPLE: BA25 Lz' = 1300 La' = 250

0.16 Kg of grease for 8 bearings. For the length compensator:

$$Q = Q \text{ min} + Q \text{ La} \frac{(La' - La)}{100} = 1.1 + 0.4 \frac{(250 - 150)}{100} = 1.5 \text{ Kg of grease}$$

MASS MOMENTS OF INERTIA

ENGINEERING DATA

J min = mass moment of inertia in [kg m²] at Lz min and La min or Lf
 J La = mass moment of inertia in [kg m²] for 100 mm length compensation La
 J Lz or J Lf = mass moment of inertia in [kg m²] for 100 mm tube

TABLE 39

| SIZE | | 18 | 22 | 25 | 28 | 31 | 35 | 39 |
|------|-------|--------|--------|--------|--------|--------|--------|--------|
| TYPE | | | | | | | | |
| AA | Lz | 795 | 855 | 985 | 1080 | 1235 | 1350 | 1495 |
| | La | 140 | 145 | 150 | 155 | 160 | 170 | 180 |
| | J min | 0.2248 | 0.5152 | 0.9791 | 1.9124 | 3.7851 | 6.5390 | 11.448 |
| | J Lz | 0.0176 | 0.0234 | 0.0422 | 0.0696 | 0.1875 | 0.4367 | 0.5762 |
| | J La | 0.0038 | 0.0094 | 0.0183 | 0.0264 | 0.0645 | 0.0809 | 0.1337 |
| AB | J | 0.1827 | 0.4530 | 0.8470 | 1.7017 | 3.2718 | 5.7159 | 10.494 |
| AC | Lf | 495 | 535 | 615 | 695 | 780 | 835 | 930 |
| | J min | 0.1492 | 0.3887 | 0.7005 | 1.4221 | 2.4648 | 4.2799 | 7.6847 |
| | J Lf | 0.0176 | 0.0234 | 0.0422 | 0.0696 | 0.1875 | 0.4367 | 0.5762 |
| AD | J | 0.1394 | 0.3759 | 0.6761 | 1.3808 | 2.3490 | 4.0840 | 7.2083 |

| SIZE | | 18 | 22 | 25 | 28 | 31 | 35 | 39 | 44 | 49 | 55 | 62 |
|------|-------|--------|--------|--------|--------|--------|--------|---------|---------|---------|---------|---------|
| TYPE | | | | | | | | | | | | |
| BA | Lz | 795 | 855 | 985 | 1080 | 1235 | 1350 | 1495 | 1680 | 1760 | 1965 | 2250 |
| | La | 140 | 145 | 150 | 155 | 160 | 170 | 180 | 190 | 200 | 210 | 230 |
| | J min | 0.2275 | 0.5240 | 1.0001 | 1.9495 | 3.8350 | 6.6307 | 11.6501 | 21.0589 | 32.5762 | 58.5372 | 111.374 |
| | J Lz | 0.0176 | 0.0234 | 0.0422 | 0.0696 | 0.1875 | 0.4367 | 0.5762 | 0.7205 | 0.8843 | 1.5793 | 1.6040 |
| | J La | 0.0038 | 0.0094 | 0.0183 | 0.0264 | 0.0645 | 0.0809 | 0.1337 | 0.1500 | 0.2560 | 0.4224 | 0.7616 |
| BB | J | 0.1854 | 0.4618 | 0.8680 | 1.7388 | 3.3217 | 5.8076 | 10.6961 | 18.9479 | 29.7552 | 53.2112 | 97.3382 |
| BC | Lf | 495 | 535 | 615 | 695 | 780 | 835 | 930 | 1140 | 1205 | 1355 | 1530 |
| | J min | 0.1519 | 0.3975 | 0.7215 | 1.4592 | 2.5147 | 4.3716 | 7.8868 | 15.0669 | 24.6962 | 44.0222 | 91.2352 |
| | J Lf | 0.0176 | 0.0234 | 0.0422 | 0.0696 | 0.1875 | 0.4367 | 0.5762 | 0.7205 | 0.8843 | 1.5793 | 1.6088 |
| BD | J | 0.1421 | 0.3847 | 0.6971 | 1.4179 | 2.3989 | 4.1757 | 7.4104 | 14.3259 | 23.5512 | 41.8252 | 88.5122 |

| SIZE | | 18 | 22 | 25 | 28 | 31 | 35 | 39 | 44 | 49 | 55 | 62 |
|------|-------|--------|--------|--------|--------|--------|--------|---------|---------|---------|---------|----------|
| TYPE | | | | | | | | | | | | |
| CA | Lz | 795 | 855 | 985 | 1080 | 1235 | 1350 | 1495 | 1680 | 1760 | 1965 | 2250 |
| | La | 140 | 145 | 150 | 155 | 160 | 170 | 180 | 190 | 200 | 210 | 230 |
| | J min | 0.2615 | 0.5575 | 1.0857 | 2.0517 | 4.0390 | 6.9691 | 12.2931 | 21.7275 | 34.3622 | 61.7192 | 116.404 |
| | J Lz | 0.0176 | 0.0234 | 0.0422 | 0.0696 | 0.1875 | 0.4367 | 0.5762 | 0.7205 | 0.8843 | 1.5793 | 1.6040 |
| | J La | 0.0038 | 0.0094 | 0.0183 | 0.0264 | 0.0645 | 0.0809 | 0.1337 | 0.1500 | 0.2560 | 0.4224 | 0.7616 |
| CB | J | 0.2194 | 0.4953 | 0.9536 | 1.8410 | 3.5257 | 6.1460 | 11.3391 | 19.6165 | 31.5412 | 56.3932 | 106.3382 |
| CC | Lf | 495 | 535 | 615 | 695 | 780 | 835 | 930 | 1140 | 1205 | 1355 | 1530 |
| | J min | 0.1859 | 0.4310 | 0.8071 | 1.5614 | 2.7187 | 4.7100 | 8.5298 | 15.7355 | 26.4822 | 47.2042 | 96.265 |
| | J Lf | 0.0176 | 0.0234 | 0.0422 | 0.0696 | 0.1875 | 0.4367 | 0.5762 | 0.7205 | 0.8843 | 1.5793 | 1.6080 |
| CD | J | 0.1761 | 0.4182 | 0.7827 | 1.5201 | 2.6029 | 4.5141 | 8.0534 | 14.9945 | 25.3372 | 45.0072 | 93.5422 |

EXAMPLE: BA25 Lz' = 1300 La' = 250

$$J = J \text{ min} + J \text{ Lz} \frac{(Lz' - Lz)}{100} + J \text{ La} \frac{(La' - La)}{100}$$

$$J = 1.0001 + 0.0422 \frac{(1300 - 985)}{100} + 0.0183 \frac{(250 - 150)}{100} = 1.1513 \text{ kg m}^2$$

UNIVERSAL SHAFT IDENTIFICATION

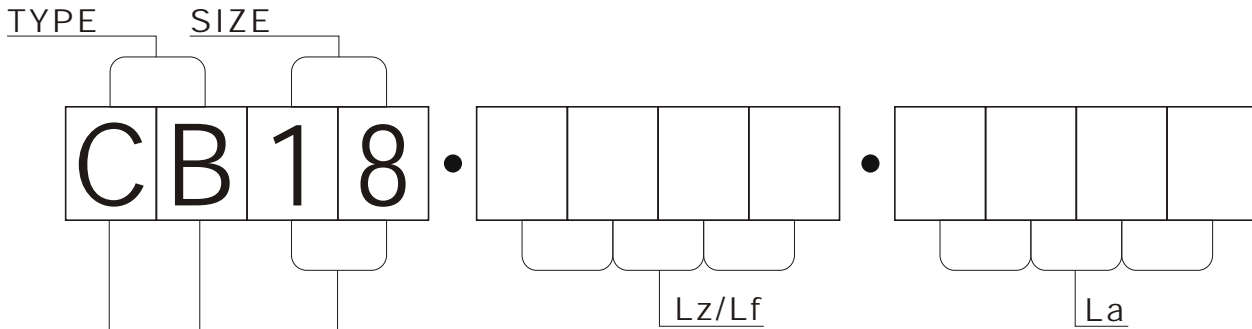

| SERIES | |
|--------|------------------------------|
| A | LIGHT |
| B | MEDIUM - STANDARD FLANGES |
| C | MEDIUM - LARGER FLANGES |
| S | HYSHAFT |
| D | HEAVY |
| E | VERTICAL - STANDARD FLANGES |
| F | EXTRA HEAVY |
| G | HEAVY - LARGER FLANGES |
| H | VERTICAL - LARGER FLANGES |
| J | EXTRA HEAVY - LARGER FLANGES |

| EXECUTION (SERIES A, B, C) | |
|----------------------------|---|
| A | Telescopic Shaft, medium length compensation |
| B | Telescopic Shaft, short design |
| C | Fix Length Shaft, tubular design |
| D | Fix Length Shaft, short design |
| E | Telescopic Shaft, long length compensation, or high torsional stiffness or special arrangement |
| F | Telescopic Shaft, medium length compensation (flange intermediate assembly) |
| G | Fix Length Shaft, flange tubular design |
| H | Fix Length Shaft, flange short design |
| J | Telescopic Shaft, long length compensation, or high torsional stiffness or special arrangement (flange intermediate assembly) |
| K | Flange Joint |

| EXECUTION (SERIES D, G, F, J) | |
|-------------------------------|---|
| A | Telescopic Shaft |
| C | Fix Length Shaft, tubular design |
| D | Fix Length Shaft, short design |
| F | Telescopic Shaft, flange intermediate design |
| G | Fix Length Shaft, flange tubular design |
| H | Fix Length Shaft, flange short design |
| K | Flange Joint |
| L | Fix Length Shaft, intermediate shaft design |
| M | Telescopic Shaft, intermediate tubular design |

| EXECUTION (SERIES S) | |
|----------------------|---|
| F | Telescopic Shaft, medium length compensation (flange intermediate assembly) |
| G | Fix Length Shaft, flange tubular design |
| H | Fix Length Shaft, flange short design |
| J | Telescopic Shaft, medium length compensation series S flange joint roll side series B weld joint pinion side, bigger rotation |
| K | Flange Joint |

EXAMPLE OF IDENTIFICATION:

UNIVERSAL SHAFT WITH LENGTH COMPENSATION
MEDIUM-LARGER FLANGES SHORT DESIGN, SIZE 18
COLLAPSED LENGTH Lz = 795, SLIDE La = 140

CODE: CB18.0795.0140

| EXECUTION (SERIES E, H) | |
|-------------------------|---|
| A | Telescopic Shaft, standard type (external flange) |
| B | Telescopic Shaft, standard type (internal flange) |
| C | Telescopic Shaft, reversed type (external flange) |
| D | Telescopic Shaft, reversed type (internal flange) |

| | | | | | | | | | | | | | | | | |
|--------------|------|----|----|----|----|----|----|----|----|-----|-----|-----|-----|-----|-----|--|
| SERIES A | SIZE | 18 | 22 | 25 | 28 | 31 | 35 | 39 | | | | | | | | |
| SERIES B - C | SIZE | 18 | 22 | 25 | 28 | 31 | 35 | 39 | 44 | 49 | 55 | 62 | | | | |
| SERIES S | SIZE | 35 | 39 | 44 | 49 | 55 | | | | | | | | | | |
| SERIES D - G | SIZE | 60 | 65 | 70 | 75 | 80 | 85 | 90 | 95 | 100 | 105 | 110 | 115 | 120 | 125 | |
| SERIES F - J | SIZE | 60 | 65 | 70 | 75 | 80 | 85 | 90 | 95 | 100 | 105 | 110 | 115 | 120 | 125 | |
| SERIES E - H | SIZE | 18 | 22 | 25 | 28 | 31 | 35 | 39 | 44 | 49 | 55 | | | | | |

COMPANION FLANGE IDENTIFICATION

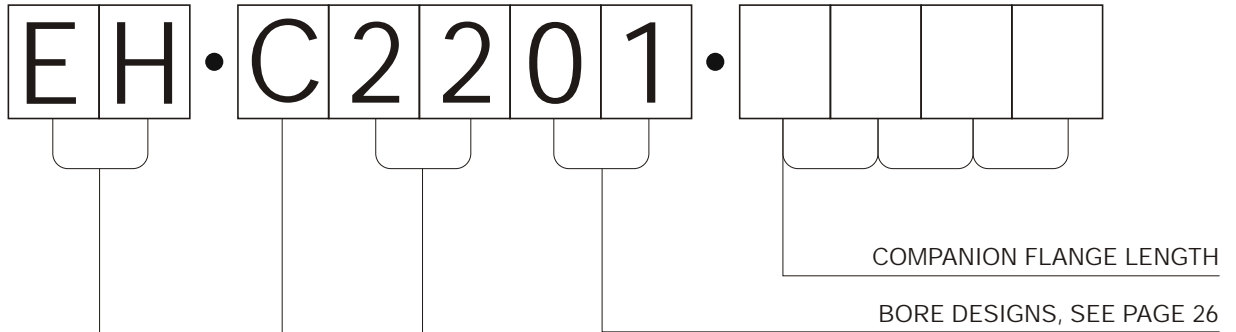

| | | | |
|---|---|--|---------|
| E | A | COMPANION FLANGE WITH INNER CENTERING, WITHOUT KEY | PAG. 18 |
| E | B | COMPANION FLANGE WITH INNER CENTERING, ACCORDING TO DIN 15452 | PAG. 18 |
| E | C | COMPANION FLANGE WITH INNER CENTERING, WITH KEY, STANDARD TYPE | PAG. 18 |
| E | D | COMPANION FLANGE WITH INNER CENTERING, WITH KEY, LARGER TYPE | PAG. 18 |
| E | E | COMPANION FLANGE WITH OUTER CENTERING, WITHOUT KEY | PAG. 20 |
| E | F | COMPANION FLANGE WITH OUTER CENTERING, ACCORDING TO DIN 15452 | PAG. 20 |
| E | G | COMPANION FLANGE WITH OUTER CENTERING, WITH KEY, STANDARD TYPE | PAG. 20 |
| E | H | COMPANION FLANGE WITH OUTER CENTERING, WITH KEY, LARGER TYPE | PAG. 20 |
| E | J | CYLINDRICAL COMPANION FLANGE WITH INNER CENTERING, WITHOUT KEY | PAG. 22 |
| E | K | CYLINDRICAL COMPANION FLANGE WITH INNER CENTERING, WITH KEY, STANDARD TYPE | PAG. 22 |
| E | L | CYLINDRICAL COMPANION FLANGE WITH INNER CENTERING, WITH KEY, LARGER TYPE | PAG. 22 |
| E | M | CYLINDRICAL COMPANION FLANGE WITH OUTER CENTERING, WITHOUT KEY | PAG. 24 |
| E | N | CYLINDRICAL COMPANION FLANGE WITH OUTER CENTERING, WITH KEY, STANDARD TYPE | PAG. 24 |
| E | P | CYLINDRICAL COMPANION FLANGE WITH OUTER CENTERING, WITH KEY, LARGER TYPE | PAG. 24 |

| SERIES | |
|--------|------------------------------|
| A | LIGHT |
| B | MEDIUM - STANDARD FLANGES |
| C | MEDIUM - LARGER FLANGES |
| S | HYSHAFT |
| D | HEAVY |
| E | VERTICAL - STANDARD FLANGES |
| F | EXTRA HEAVY |
| G | HEAVY - LARGER FLANGES |
| H | VERTICAL - LARGER FLANGES |
| J | EXTRA HEAVY - LARGER FLANGES |

EXAMPLE OF IDENTIFICATION:

COMPANION FLANGE WITH OUTER CENTERING, WITH KEY, LARGER TYPE
 UNIVERSAL SHAFT SERIES "C"
 SIZE 22, BORE DESIGN 01, LENGTH 295

CODE: EH.C2201.0295

| | | | | | | | | | | | | | | | |
|--------------|------|----|----|----|----|----|----|----|----|-----|-----|-----|-----|-----|-----|
| SERIES A | SIZE | 18 | 22 | 25 | 28 | 31 | 35 | 39 | | | | | | | |
| SERIES B - C | SIZE | 18 | 22 | 25 | 28 | 31 | 35 | 39 | 44 | 49 | 55 | 62 | | | |
| SERIES S | SIZE | 35 | 39 | 44 | 49 | 55 | | | | | | | | | |
| SERIES D - G | SIZE | 60 | 65 | 70 | 75 | 80 | 85 | 90 | 95 | 100 | 105 | 110 | 115 | 120 | 125 |
| SERIES F - J | SIZE | 60 | 65 | 70 | 75 | 80 | 85 | 90 | 95 | 100 | 105 | 110 | 115 | 120 | 125 |
| SERIES E - H | SIZE | 18 | 22 | 25 | 28 | 31 | 35 | 39 | 44 | 49 | 55 | | | | |

INSTALLATION, MAINTENANCE AND LUBRICATION

1) TRANSPORT AND STORAGE

- 1.1 MAINA universal shafts are generally supplied assembled (complete male and female assembly), balanced (if necessary) and, unless otherwise requested, painted (coat of primer + final color) according to MAINA specification PFB 1104.
- 1.2 A proper surface protection coat normally realizes protection against corrosion on the flange machined surfaces. Different anticorrosion treatments shall be required in the order.
Bearings and length compensator are pre-lubricated.
- 1.3 Lift horizontally, using suitable nylon ropes. If handling in a vertical plane, secure the shaft in order to prevent the splined parts from separating, before lifting.

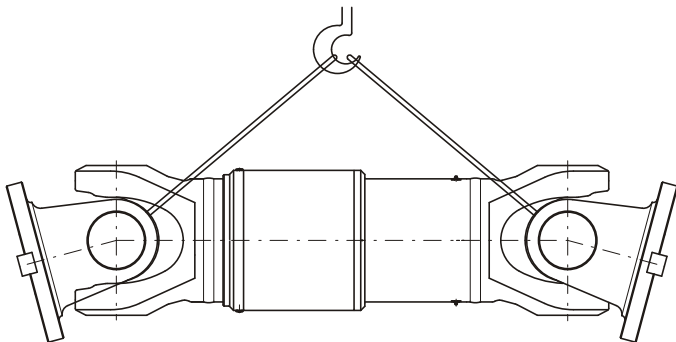

- 1.4 Transport and store in horizontal position.
The lifting equipment have to be selected according to the weights shown in our drawings or in our catalogue.
- 1.5 Do not hang or transport in vertical position.
For vertical transport it is necessary to require a special safeguard to keep the parts together.
- 1.6 Packings must be able to avoid any impact to the universal shafts and must protect them from any environmental event and from humidity and condensate.
- 1.7 Store preferably on suitable wooden frames. Avoid any kind of impact when handling and storing.
Shocks and impacts, during transport and storage, could damage bearings, splined parts and their protective caps.
- 1.8 For long period of storage, machined parts should be protected against corrosion.

- 1.9 On request MAINA can provide 2 types of antioxidant protection as follows:

- a) indoor storage, short period (max 1 month), with an oil based, transparent, amber film, which need not be removed before installation;
- b) indoor storage, medium period or shipment by sea (max 3 months) with a dry, wax based, transparent film, which must be removed with a solvent, before installation.

For longer storage it is necessary to check the surface conditions and eventually cover with a new protection film.

- 1.10 For long storage (exceeding three months) relubricate bearings and length compensator, before installation.

2) ASSEMBLY

- 2.1 Remove the universal shaft from the packaging and check its conservation state.
- 2.2 Before assembling, flanges and companion flanges must be thoroughly cleaned to guarantee a perfect contact between each surface.
- 2.3 Balance weights should never be removed.
- 2.4 Splined parts must never be disassembled, to avoid interchanging, with consequent misalignment and unbalance of the unit.
- 2.5 The universal shaft yokes must be aligned. Check the arrow markings.
- 2.6 In the companion flanges, the coaxial tolerance of centering and the perpendicular position must be in a restricted range.
- 2.7 Heat the companion flanges uniformly (100÷150 °C) for key fitting and (300÷350 °C) for shrink fitting before assembling onto the shafts. Wait for the complete cooling of companion flanges, before assembling the universal flanges.
Ask for MAINA specification PFB 1202 (in case of shrink fitting) and PFB 1100 (in case of key fitting).
- 2.8 The companion flanges must be firmly fix and centered onto the shaft.
Check that:
- no backlash is present,
 - no end float is present,
 - keys or splined shafts have no clearance on their flanks.

INSTALLATION, MAINTENANCE AND LUBRICATION

- 2.9 Check that the dimensions between shaft ends (minimum and maximum distances) are in accordance to MAINA drawings.

NOTE:

When installing fix length universal shafts, one of the units must be free to move, to compensate slight length variation, due to manufacturing tolerances or temperature changes.

- 2.10 WHEREVER PEOPLE OR MATERIAL COULD BE ENDANGERED BY OPERATING UNIVERSAL SHAFTS, SAFETY DEVICES MUST BE PROVIDED BY THE USER, FOLLOW APPLICABLE SAFETY CODES AND REGULATIONS.

- 2.11 Before fitting the joint flanges, their surfaces have to be accurately cleaned. They must be free from grease, coat or rust.

- 2.12 Complete flange bolting sets are available on request. MAINA normally provide:

- hexagon or cylindrical headed bolts (in accordance to DIN 931 - 12.9 or 10.9)

- self-locking nuts (according to DIN 980 - 10 or 8).

The bolts are to be tightened with a dynamometrical wrench or another similar device, in accordance to the torque table of page 30 or our drawings.

The self-locking nuts lose their features and must be replaced, after a certain period of operations (about 5 screwings and unscrewings).

Normally the bolts are inserted from the companion flange side, fitting the tightening nuts on the flanges of the universal shaft. In special cases it is also possible to insert the bolts from the joint side or to use stud bolts.

NOTE:

DO NOT LUBRICATE THE BOLTS OR NUTS WITH LUBRICANTS CONTAINING MoS₂.

- 2.13 Bearings and length compensator have been pre-lubricated at our workshop and do not require lubrication before installation in case of short period of storage. See section "LUBRICATION" for types of tube and intervals of lubrication.

- 2.14 If the setting at work takes place three months later than the assembly, check the conditions of universal shafts and relubricate.

3) LUBRICATION

- 3.1 The performance and working life of universal shafts greatly depend on a lubrication programme. Do not let the spline slide before lubricating it.

- 3.2 MAINA recommend the following lubrication intervals:

- FIRST YEAR

Every 200 ÷ 350 hours of actual operation time.

- AFTER FIRST YEAR

For normal applications every 2000 ÷ 3000 hours or every six months.

For heavy duty applications every 500 ÷ 1000 hours or every two or three months.

The intervals depend on: frequency of impacts, level of load, environmental conditions, rotating speed, reversing operation, operating angle, seal condition, frequency of shaft movements, length of stroke, movements under/no load. Particularly unfavourable working conditions may require shorter grease intervals.

- 3.3 The lubrication points of standard universal shafts are placed respectively:

- in the centre of journal cross or on each bearing bottom, to lubricate the bearings

- on the spacer and on the cover to lubricate the length compensator.

- 3.4 NOTE:

a) When regreasing, use a compatible lubricant.

b) Grease nipples must be cleaned before greasing.

c) Do not lubricate with too high pressure:
MAXIMUM PERMISSIBLE GREASE PRESSURE 6 BAR.

d) Pump the grease in the bearings until the old lubricant flows out of seals or relief valves.

e) Spacer side containing the splined shaft must be completely filled with grease. Lubricate in the minimum length compensation position.

Do not pump more grease than required in the drawing. After lubricating make the spline slide with opened plugs once or twice.

- 4) LUBRICANTS

- 4.1 For normal applications MAINA recommend mainly lithium thickened greases.

- 4.2 For temperature ranges from +90 to -30°C, use grease with Penetration 1 or 2, according to DIN 51804. Please contact MAINA if the temperature is outside this range.

INSTALLATION, MAINTENANCE AND LUBRICATION

4.3 For very important heavy duties MAINA recommend the following specification of lubricant:

| | |
|-------------------------|------------------------------|
| Thickener | lithium |
| Worked penetration | 315 ÷ 325 possible 265 ÷ 295 |
| Dropping point | 174 ÷ 193°C possible 165°C |
| Thickener percentage | 7% |
| Mineral oil | 75% |
| Oil viscosity at 40°C | 1000 ÷ 1500 cSt |
| Oil viscosity at 100°C | 60 ÷ 100 cSt |
| Addition agents EP type | 2% |
| MoS2 mineral addendum | 5 ÷ 10% |
| Timken EP OK load | 18 kg |
| Corrosion | negative |

MAINA recommend the following greases for universal shaft size equal to or bigger than size 39 and for heavy duty conditions (rolling stand):

| | |
|---------|-------------------------|
| CASTROL | CASTROL MOLUB-ALLOY 870 |
| WULKEN | MOLUBROL W/PA10 |
| OPTIMOL | LONGTIME PD2 |
| KLUBER | KLUBERLUB BE41-1501 |
| MOBIL | MOBILUX EP111 |
| SIGNAL | MOLYVIS GLA SPECIAL |

Greases must also:

- contain oxidation inhibitors
- be water-repellent
- be free of alkalis, acids, impurities
- have a good thermal stability.

4.4 For high operation speed (>500 rpm), the addition agents must have a good resistance to centrifugation.

4.5 For moderate industrial services MAINA recommend the following greases:

| | |
|--------|----------------|
| BP | ENERGREASE LS2 |
| ESSO | BEACON EP2 |
| SHELL | ALVANIA EP2 |
| MOBIL | MOBILUX 2 |
| TEXACO | MULTIFAK EP2 |

Synthetic greases may also be used.

4.6 The right type of grease to employ is shown in the drawing. For grease quantity see page 41.

5) MAINTENANCE

5.1 To ensure a trouble-free life of the universal shafts, a maintenance schedule and a lubrication programme are essential.

The following should be taken as a guide, the frequency of inspections depending on working conditions and type of equipment the universal shafts are installed on.

5.2 INITIAL INSPECTION

| | |
|-----|--------------------------------|
| 1st | check after approx 1 week |
| 2nd | check after approx 2 ÷ 3 weeks |
| 3rd | check after approx 4 ÷ 6 weeks |

5.3 REGULAR INSPECTION

Every 1000 ÷ 2000 working hours or, at least, once a year for light applications and every six months for heavy duty applications.

The periodical checks are to be carried out as follows:

- 1) Bolts
Tighten when necessary.
- 2) Wear
Check the following:
 - radial clearance of bearings
 - end float of the journal cross
 - radial clearance of the slip stub shaft
 - torsional clearance of the slip stub shaft
- 3) Noise/Vibration
Any unusual sound or excessive vibrations should be located and corrected immediately.
- 4) Temperature
Make sure that bearings do not exceed the ambient temperature by more than 35 ÷ 40°C.
- 5) Position of the companion flanges
Check that the supports have not yielded because of base settlements or deformations.
- 6) Lubrication
Check that no grease dripping is present, due to centrifugation or other causes, i.e. wear or breakage of seals, wear or loss of grease nipples, plugs or relief valves.

For any further information about installation, maintenance and lubrication, ask for MAINA specification PFB 1400 (series A-B-C-E-H) and PFB 1403 (series D-G-F-J).

SPARE PARTS IDENTIFICATION



FLANGE DIAMETER
FLANGE YOKE DESIGNS

- 01 WITH KEY
- 02 HIRTH
- 03 DOG TEETH

| | | |
|---|---|----------------------------|
| D | A | KEY |
| D | B | FLANGE YOKE |
| D | C | HEXAGONAL BOLT / STUD BOLT |

As for the flange yoke with larger flange than the corresponding of series C,G,J, it is necessary to add in the code the flange diameter

| SERIES | | |
|--------|------------------------------|-------------------------------|
| A | LIGHT | D HEAVY |
| B | MEDIUM - STANDARD FLANGES | E VERTICAL - STANDARD FLANGES |
| C | MEDIUM - LARGER FLANGES | F EXTRA HEAVY |
| G | HEAVY - LARGER FLANGES | H VERTICAL - LARGER FLANGES |
| J | EXTRA HEAVY - LARGER FLANGES | |

EXAMPLE OF IDENTIFICATION:
FLANGE YOKE WITH KEY
UNIVERSAL SHAFT SERIES "C"
SIZE 22 FLANGE DIAMETER = 285
CODE DB.C2201.285

EXAMPLE OF IDENTIFICATION:
FLANGE YOKE WITH KEY
UNIVERSAL SHAFT SERIES "B"
SIZE 22
CODE DB.B2201

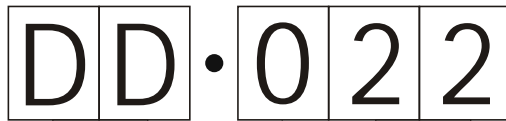

| | | |
|---|---|-----------------------------|
| D | D | JOURNAL CROSS WITH BEARINGS |
| D | E | JOURNAL CROSS |
| D | F | YOKE WITH SPLINED MALE |

| SERIES | |
|--------|----------------------------|
| 0 | SERIES A, B, C, D, F, G, J |
| 1 | SERIES E, H |

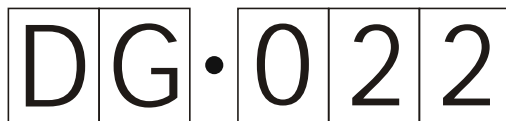

| | | | | | |
|---|---|--------------------------|---|---|------------------------------|
| D | G | BEARING SEAL | D | Q | HOLLOW EXTERNAL YOKE |
| D | H | BEARING | D | R | HOLLOW INTERNAL YOKE |
| D | J | YOKE WITH SPLINED FEMALE | D | S | BEARING COVER |
| D | K | TUBE YOKE | D | T | COVER CAP SCREW |
| D | L | SPLINED FEMALE | D | U | THRUST BEARING |
| D | M | SLIDING SEAL | D | V | SYNTHETIC DISC |
| D | N | SPLINED MALE | D | W | ANTI-PIERCING BEARING DEVICE |
| D | P | COVER | | | |

| SERIES | |
|--------|------------|
| 0 | ALL SERIES |

| | | | | | | | | | | | | | | | | |
|--------------|------|----|----|----|----|----|----|----|----|-----|-----|-----|-----|-----|-----|--|
| SERIES A | SIZE | 18 | 22 | 25 | 28 | 31 | 35 | 39 | | | | | | | | |
| SERIES B - C | SIZE | 18 | 22 | 25 | 28 | 31 | 35 | 39 | 44 | 49 | 55 | 62 | | | | |
| SERIES D - G | SIZE | 60 | 65 | 70 | 75 | 80 | 85 | 90 | 95 | 100 | 105 | 110 | 115 | 120 | 125 | |
| SERIES F - J | SIZE | 60 | 65 | 70 | 75 | 80 | 85 | 90 | 95 | 100 | 105 | 110 | 115 | 120 | 125 | |
| SERIES E - H | SIZE | 18 | 22 | 25 | 28 | 31 | 35 | 39 | 44 | 49 | 55 | | | | | |

SPARE PART IDENTIFICATION

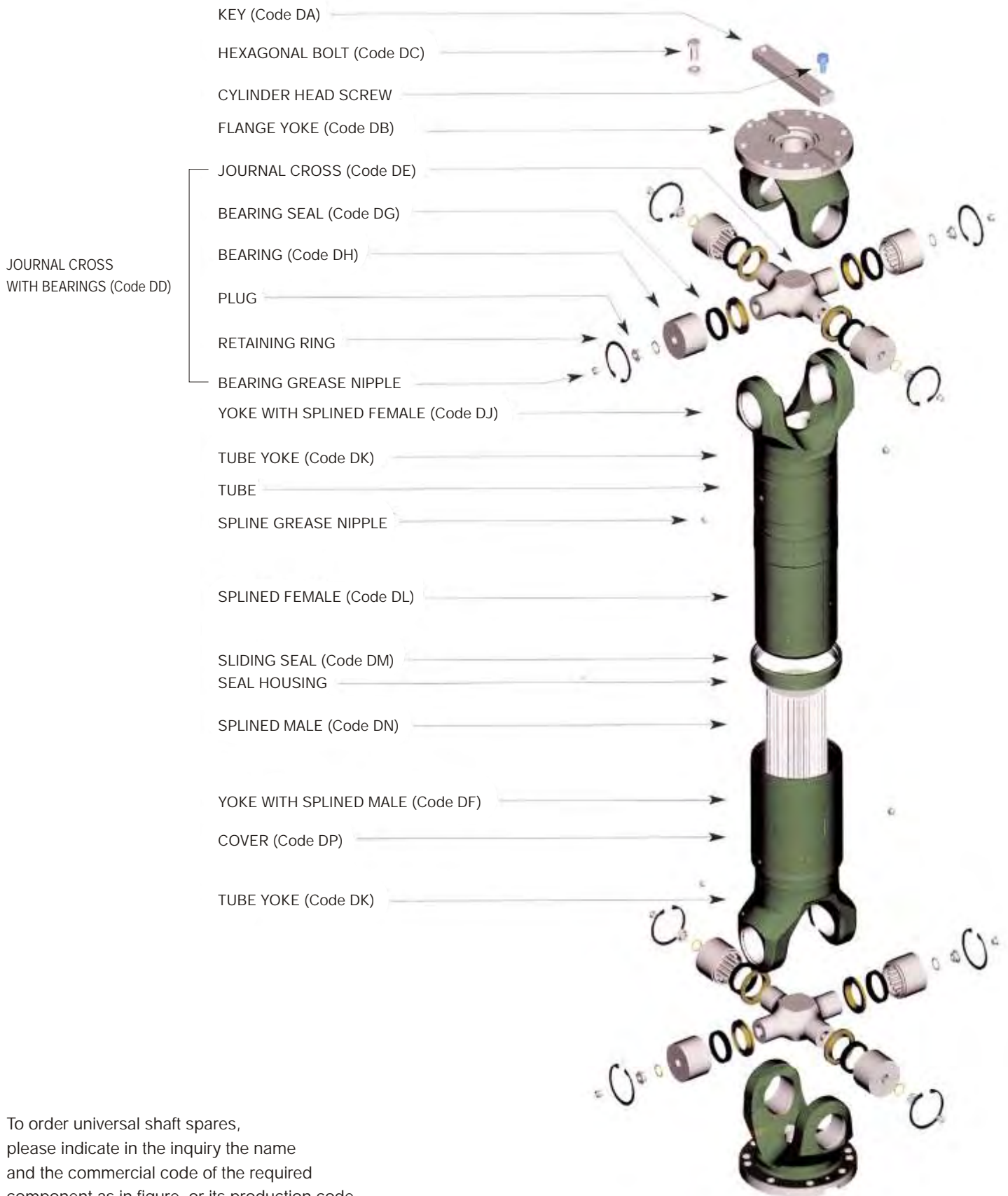

To order universal shaft spares, please indicate in the inquiry the name and the commercial code of the required component as in figure, or its production code indicated in the assembly drawing.

TORQUE MONITORING

Strength of Maina Company is the design and production of special torque monitoring devices, particularly for extremely severe applications as in plate mills, steckel mills and hot strip mills, always complying with the transmission dimensions. They base on the application of strain gauges on an external cylindrical surface, subject to torque flow, which deform by transmitting a signal to telemetric device through a rotor aerial. The signals, decoded by a special software, enable obtaining the time torque diagram.



GENERAL MEASUREMENT CONFIGURATION

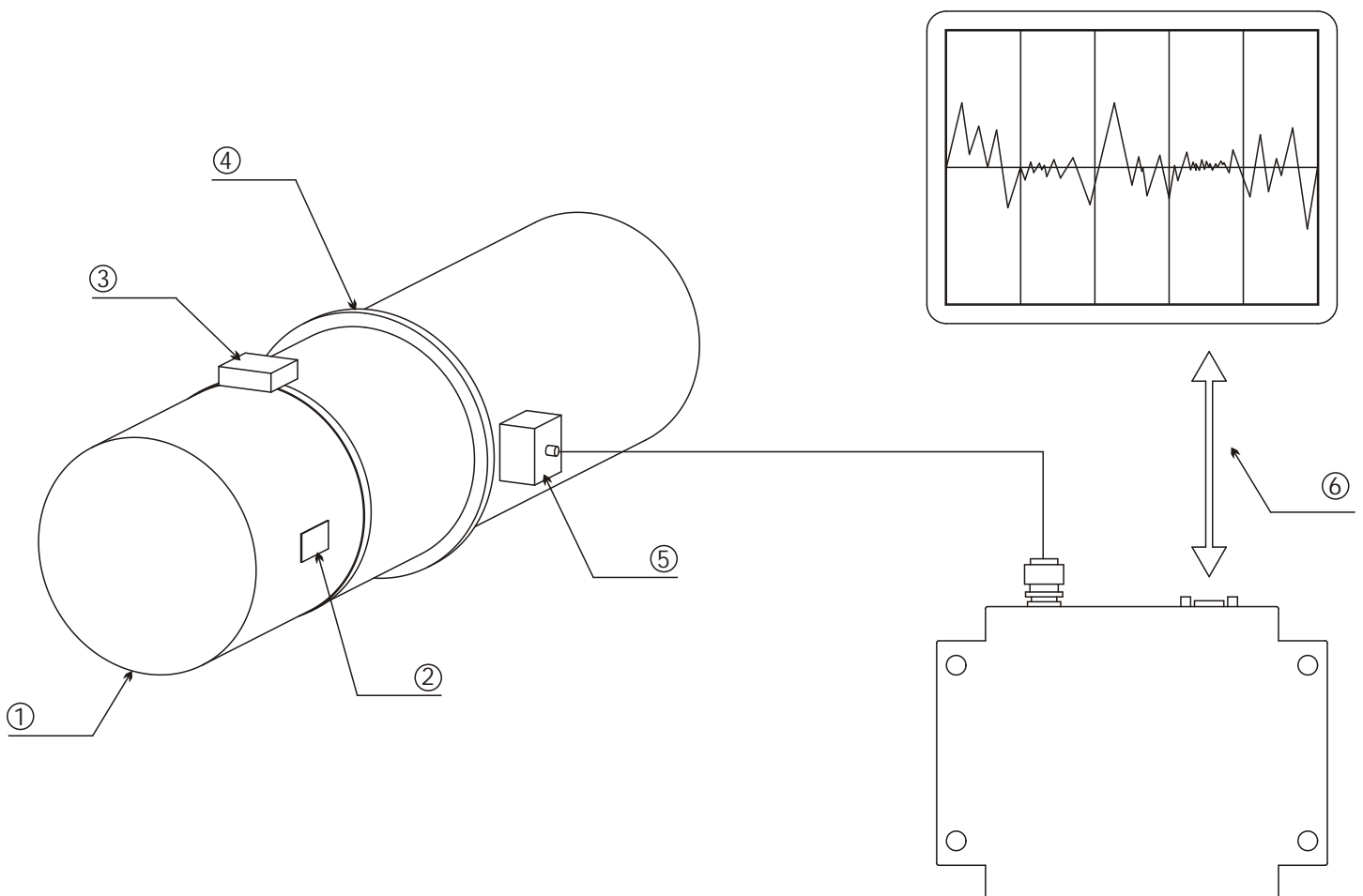

- ① Shaft
- ② Sensor
- ③ Sensor signal amplifier
- ④ Rotor antenna
- ⑤ Stator antenna
- ⑥ Power supply and torque signal

TECHNICAL DATA FOR SELECTION

UNIVERSAL SHAFTS FOR GENERAL MACHINERY APPLICATION

Installation

Type of installation.....
 Type of operation.....
 Shocks.....
 Reversing service.....
 Intermitted service.....
 Ambient conditions.....
 Ambient temperature.....



Motor

Type.....
 Torque..... kNm
 Speed..... rpm
 Power range..... kW
 Speed range..... rpm
 Max continuous torque..... kNm
 Cut out torque..... kNm
 Shaft end diameter..... mm - length..... mm

Intermediate gear

Type of clutch/flexible coupling.....
 Ratio.....
 Number of inputs.....
 Number of outputs.....
 Input shaft end diameter..... mm - length..... mm
 Output shaft end diameter..... mm - length..... mm
 Max. perm. input universal shaft diameter..... mm
 Max. perm. output universal shaft diameter..... mm

Universal shaft

Position of universal shaft.....
 Normal working torque..... kNm
 Max working torque..... kNm
 Impact torque..... kNm
 Cut out torque..... kNm
 Speed range..... rpm
 Working length min/max..... mm
 Max. movement..... mm
 Working deflection angle - horizontal  - vertical 
 Universal shaft connection - flange - hub
 Input shaft end diameter..... mm - length..... mm
 Required universal shaft size.....

TECHNICAL DATA FOR SELECTION

UNIVERSAL SHAFTS FOR ROLLING MILL DRIVES

Installation

Type of installation.....
 Type of operation.....
 New equipment/overhaul.....
 Ambient conditions.....
 Ambient temperature.....

Motor

Type/adjustment.....
 Power..... kW
 Speed..... rpm
 Nominal torque..... kNm
 Max continuous torque..... kNm
 Cut out torque..... kNm



Intermediate gear / Pinion stand

Type of high speed flexible coupling.....
 Ratio.....
 Number of outputs.....
 Output shaft end diameter..... mm - length..... mm
 Output max. perm. universal shaft diameter..... mm

Driven unit

Normal working torque..... kNm
 Max working torque..... kNm
 Impact torque..... kNm
 Cut out torque..... kNm
 Torque distribution - top..... % - middle..... % - bottom..... %
 Roll speed range..... rpm
 Roll diameter max/min..... mm
 Roll end diameter..... mm - length..... mm
 Shape of roll end.....
 Roll change horizontal/vertical.....

Universal shaft

Working deflection angle - min.....  - max..... 
 Working length min/max..... / mm
 Roll movement max..... mm
 Quick release device requested - yes - no
 Universal shaft connection - flange - hub
 Required universal shaft size.....



HEAD OFFICE: MAINA ORGANI DI TRASMISSIONE S.p.A. - CORSO ALESSANDRIA 160 - 14100 ASTI
PHONE: +39.0141.492811 - FAX +39.0141.492860 - E-mail: info@maina.it
