

Fenner®

SMSR

The Fenner® SMSR PowerPLUS offers a rugged design and a 50% increase in the power to weight ratio over older versions. The powerPLUS range is more compact for easier handling and features an increased range of bore sizes.

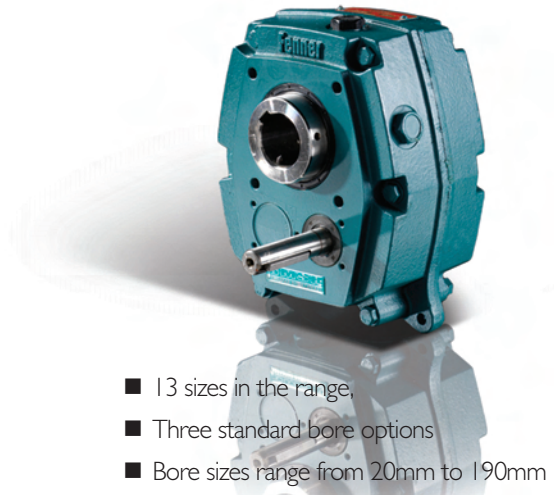

- 13 sizes in the range
- Three standard bore options
- Bore sizes range from 20mm to 190mm
- Torque capacity up to 45,000Nm
- Taper-Grip bush for easy removal and fitting
- Ratios up to 200:1 with a simple belt drive

Geared Drives Design Data Required

- **Motorised (integral motor) or non-motorised?** electrical supply available
- **If motorised:** any special motor features required (brake, clutch, flameproof etc.)
- **If non-motorised:** type of prime mover
rotational speed of prime mover
power rating of prime mover
is an input shaft coupling required?
if so, prime mover shaft dia.
- **Shaft mounting or foot mounted?**
if shaft mounted, machine shaft diameter/length
if foot mounted, is an output shaft coupling required?
- **Orientation of input/output**
parallel or right angle?
- **Type of driven machine**
- **Rotational speed of driven machine**
constant or variable over what range?
- **Power absorbed by driven machine**
(or required output torque)
- **Hours/day duty & start/stop frequency**

SMSR	Page
Selection	377
Power Ratings	378
Output Hub Dimensions	379
SMSR Power Plus Dimensions	380
Exact Ratios	381
Taper Grip	382
Ordering Instructions	383
Belt Drives	384
Installation	388
Spare Parts	389
Lubrication	391
SPIRAL - T	
Selection	392
Power Ratings	393
Dimensions	393



GEARBOX SELECTION PROCEDURE

(a) Service Factor

From Table 1 select the service factor applicable to the drive.

(b) Design Power

Multiply the absorbed power (or motor power if absorbed power not known) by the service factor chosen in step (a).

NOTE:

Gear units are momentarily capable of transmitting twice (2x) the rated capacity on start or during operation.

(c) Unit Selection

Using the value from step (b) refer to the power rating tables on page 276 and select the correct size of unit.

The choice of single or double reduction gearbox will be determined by the output speed required. The normal operating speeds for each of the gearboxes may be observed in the power rating and belt drive tables.

For other speeds consult your local Authorised Distributor.

BELT DRIVE SELECTION

Selection of associated belt drive for 1440 rev/min. electric motors

(d1) Output Speed

Refer to the Drive Selection Tables (pages 283 to 286 and under the appropriate gearbox size and ratio read down the column headed 'Output Speed' until an Output Speed equal or

near to that required is found.

The suggested ratio is given in the first column.

(e1) Pulley Diameters

Read across from the chosen output speed to obtain both driving and driven pulley pitch diameters, groove section and the appropriate number of belts.

NOTE:

In many instances one belt is recommended, being adequate for power transmission purposes; where customer preference is for multi-belt drives consult your local Authorised Distributor.

(f1) Centre Distance

Belt length and centre distance can be found by referring to pages 40-51.

(g1) Hub Bore Size

Refer to the output hub dimensions table on page 277 for the range of bore sizes available.

Selection of associated belt drive for driving speeds other than 1440 rev/min.

(d2) Gearbox Input Shaft Speed

Multiply the gearbox output speed by the exact gear ratio (found in the table on page 279) to obtain the gearbox input shaft speed.

(e2) Selection of 'V'-Drive

The correct belt drive can now be selected by referring to page 38.

NOTE:

Wedge belt drives shown on pages 283 to 286 have been selected to give the most economical total drive package for the

speed required. If it is necessary to design a special drive it is advisable to consult your local Authorised Distributor.

Torque arm should preferably be in tension when unit is in operation. See page 287.

If in any doubt consult your local Authorised Distributor.

EXAMPLE

A Shaft Mounted Speed Reducer is required for a uniformly loaded elevator which absorbs 3.6 kW at 50 rev/min. The prime mover is a 4 kW 1440 rev/min. direct on line start electric motor. A belt drive is required between the motor and gearbox at approximately 700 mm centres running for up to 24 hours/day.

SOLUTION

Selection Procedure

(a) Service factor

From Table 1 the service factor is 1.25.

(b) Design Power

Using the elevator absorbed power of 3.6 kW.

Design Power = 1.25 x 3.6 = 4.5 kW.

(c) Unit Selection

Using 4.5 kW as the basis for selection reference to the power rating tables (page 276) indicates that an E13 or E20 gear unit will transmit 6.48 kW at 50 rev/min.

Selection of associated belt drive

(d) Output Speed

A more economic belt drive will be obtained if the 20:1 ratio gearbox is selected, and by reference to page 284 in the gearbox drive tables 50 rev/min. is obtainable.

(e) Pulley Diameters

On the line giving the output speed of 50 rev/min read across and note the driving and driven pulley pitch diameters together with the numbers of belts required, which for this case is 106 mm and 150 mm, using 2 XPA Wedge Belts.

(f) Belt Selection

By reference to page 44 it can be seen that XPA 1800 belts give 699 mm centres.

(e) Available Bores

By referring to the output hub bore dimensions table on page 277, it can be seen that the size E is available with a range of bore sizes in both parallel bore and Taper Grip bush.

Parallel bore sizes are 55, 50 and 65mm whilst Taper Grip is available in 42mm and 55mm.

TABLE 1—SERVICE FACTORS

Types of Driven Machine	Operational Hours Per Day		
	Under 10	10 to 16	Over 16
Uniform Agitators and Mixers - liquid or semi-liquid Blowers – centrifugal Bottling Machines Conveyors and Elevators – uniformly loaded Cookers Laundry Washing Machines – non-reversing Line Shafts Pumps – centrifugal and gear Wire Drawing Machines	1.00	1.12	1.25
Moderate Shock Agitators and Mixers – variable density Conveyors – not uniformly loaded Cranes, travel motion and hoisting Drawbench Feeders – pulsating load Hoists Kilns Laundry Tumblers Lifts Piston Pumps – with 3 or more cylinders Pulp and Paper making machines Rubber Mixers and Calenders Rotary Screens Textile Machinery	1.25	1.40	1.60
Heavy Shock Brick presses Briquetting Machines Conveyors – reciprocating and shaker Crushers Feeders – reciprocating Hammer Mills Piston Pumps – 1 or 2 cylinders Rubber Masticators Vibrating Machines	1.60	1.80	2.00

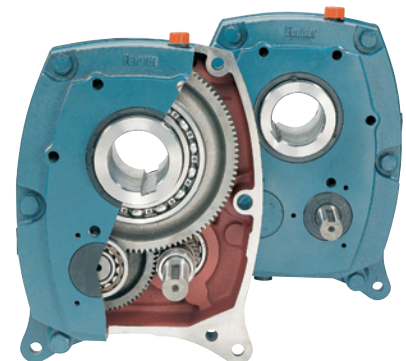

Power Ratings

POWER RATINGS (KW) 5:1 UNITS (SINGLE REDUCTION)

Output rev/min	B	C	D	E	F	G	H	J	S	T
100	2.68	4.62	7.24	11.36	16.64	28.80	41.3	63.5	86.4	113.7
110	2.87	4.84	7.58	11.89	17.42	30.14	43.3	66.5	90.4	119.0
120	3.13	5.05	7.91	12.42	18.20	31.48	45.2	69.5	94.5	124.3
130	3.36	5.27	8.25	12.95	18.97	32.83	47.1	72.4	98.5	129.7
140	3.56	5.49	8.59	13.48	19.75	34.17	49.1	75.4	102.5	135.0
150	3.62	5.70	8.93	14.01	20.53	35.52	51.0	78.4	106.5	140.3
160	3.73	5.92	9.27	14.54	21.30	36.86	52.9	81.3	110.6	145.6
170	3.83	6.13	9.60	15.07	22.08	38.20	54.9	84.3	114.6	150.9
180	3.94	6.35	9.94	15.60	22.86	39.55	56.8	87.3	118.6	156.2
190	4.04	6.57	10.28	16.13	23.63	40.89	58.7	90.2	122.7	161.5
200	4.20	6.78	10.62	16.66	24.41	42.24	60.6	93.2	126.7	166.8
210	4.31	7.00	10.95	17.19	25.19	43.58	62.6	96.2	130.7	172.1
220	4.41	7.21	11.29	17.72	25.96	44.92	64.5	99.1	134.8	177.4
230	4.53	7.43	11.63	18.25	26.74	46.27	66.4	102.1	138.8	182.7
240	4.66	7.64	11.97	18.78	27.52	47.61	68.4	105.0	142.8	188.0
250	4.78	7.86	12.31	19.31	28.29	48.95	70.3	108.0	146.9	193.3
260	4.89	8.08	12.64	19.84	29.07	50.30	72.2	111.0	150.9	195.5
270	5.04	8.29	12.98	20.37	29.85	51.64	74.1	113.9	154.9	
280	5.20	8.51	13.32	20.90	30.62	52.99	76.1	115.9	159.0	
290	5.36	8.72	13.66	21.43	31.40	54.33	78.0		160.2	
300	5.46	8.94	13.99	21.96	32.18	55.67	79.9			
310	5.62	9.15	14.33	22.49	32.95	57.02	81.9			
320	5.78	9.37	14.67	23.02	33.73	58.36	83.8			
330	5.88	9.59	15.01	23.55	34.51	59.70				
340	6.09	9.80	15.35	24.08	35.29	61.05				
350	6.30	10.02	15.68	24.61	36.06	62.39				
360	6.41	10.23	16.02	25.14	36.84	63.74				
370	6.62	10.45	16.36	25.67	37.62	65.08				
380	6.72	10.66	16.70	26.20	38.39					
390	6.93	10.88	17.04	26.73	39.17					
400	7.14	11.10	17.37	27.26	39.95					
Torque at 100 rev/min Nm	256	442	691	1085	1589	2750	3949	6068	8250	10862

CONSULT YOUR LOCAL
AUTHORISED DISTRIBUTOR

POWER RATINGS (KW) 13:1, 20:1 AND 25:1 UNITS (DOUBLE REDUCTION)

Output rev/min	B	C	D	E	F	G	H	J	S	T	K	L	M
10	0.29	0.54	0.85	1.34	1.96	3.39	4.86	7.5	10.2	13.4	19.0	26.4	46.1
12	0.36	0.67	1.04	1.64	2.40	4.16	5.97	9.2	12.5	16.4	22.5	31.4	54.9
14	0.42	0.79	1.24	1.94	2.84	4.92	7.07	10.9	14.8	19.4	25.9	36.3	63.5
16	0.47	0.91	1.43	2.24	3.29	5.69	8.17	12.6	17.1	22.5	29.3	41.3	72.1
18	0.53	1.04	1.62	2.55	3.73	6.46	9.27	14.2	19.4	25.5	32.6	46.1	80.5
20	0.59	1.16	1.82	2.85	4.18	7.22	10.37	15.9	21.7	28.5	35.9	51.0	88.9
22	0.63	1.28	2.01	3.15	4.62	7.99	11.47	17.6	24.0	31.6	39.2	55.7	97.1
24	0.69	1.41	2.20	3.46	5.06	8.76	12.57	19.3	26.3	34.6	42.3	60.4	105.3
26	0.75	1.53	2.39	3.76	5.51	9.53	13.68	21.0	28.6	37.6	45.6	65.1	113.0
28	0.81	1.65	2.59	4.06	5.95	10.29	14.78	22.7	30.9	40.7	48.7	69.7	120.6
30	0.86	1.78	2.78	4.36	6.39	11.06	15.88	24.4	33.2	43.7	51.7	74.4	128.0
32	0.92	1.90	2.97	4.67	6.84	11.83	16.98	26.1	35.5	46.7	54.9	78.8	135.2
34	0.98	2.02	3.17	4.97	7.28	12.59	18.08	27.8	37.8	49.7	57.9	83.4	142.5
38	1.10	2.15	3.36	5.27	7.72	13.36	19.18	29.5	40.1	52.8	63.7	92.5	157.0
40	1.16	2.27	3.55	5.57	8.17	14.13	20.29	31.2	42.4	55.8	66.6	96.8	164.2
42	1.20	2.39	3.74	5.88	8.61	14.90	21.39	32.9	44.7	58.8	69.2	101.1	171.5
46	1.30	2.51	3.94	6.18	9.05	15.66	22.49	34.6	47.0	61.9	74.3	109.4	186.0
50	1.42	2.64	4.13	6.48	9.50	16.43	23.59	36.3	49.3	64.9	79.0	117.5	199.2
52	1.47	2.76	4.32	6.78	9.94	17.20	24.69	37.9	51.6	67.9	81.5	120.8	206.5
54	1.52	2.88	4.52	7.09	10.38	17.96	25.79	39.6	53.9	71.0	83.8	125.6	213.7
58	1.64	3.01	4.71	7.39	10.83	18.73	26.89	41.3	56.2	74.0	88.5	132.8	225.8
62	1.76	3.13	4.90	7.69	11.27	19.50	28.00	43.0	58.5	77.0	93.0	140.1	237.9
66	1.86	3.25	5.09	7.99	11.71	20.27	29.10	44.7	60.8	80.0	97.5	147.3	248.7
70	1.96	3.38	5.29	8.30	12.16	21.03	30.20	46.4	63.1	83.1	102.0	154.6	259.6
74	2.06	3.50	5.48	8.60	12.60	21.80	31.30	48.1	65.4	86.1	104.1	157.0	270.5
78	2.15	3.72	5.83	9.15	13.41	23.20	33.31	51.2	69.6	91.6	110.4	167.8	280.1
80	2.23	3.95	6.18	9.70	14.22	24.60	35.32	54.3	73.8	97.2	112.6		
85	2.34	4.17	6.54	10.26	15.03	26.00	37.33	57.4	78.0	102.7			
90	2.48	4.40	6.89	10.81	15.84	27.40	39.34	60.5	82.2	108.2			
95	2.61	4.62	7.24	11.36	16.64	28.80	41.35	63.5	86.4	113.6			
100	2.73	4.62	7.24	11.36	16.64	28.80	41.35		86.4				
Torque at 10 rpm (Nm)	277	519	812	1276	1870	3235	4645	7139	9706	12778	18120	25254	44051

CONSULT YOUR LOCAL
AUTHORISED DISTRIBUTOR

The dotted line shows the limit of recommended output speed for reducers with 20:1 and 25:1 ratios.
For higher speeds use a 13:1 or 5:1 reducer.

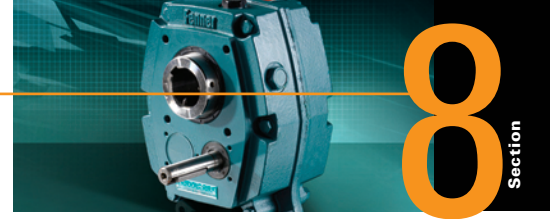

Output Hubs

OUTPUT HUB DIMENSIONS ('B' SEE PAGE 284)

Reducer Size	Standard Hub Bore (1)	Standard Hub Bush bores	Alternative Hub Bore †	Alternative Hub Bush Bores	Taper-Grip Standard Hub Bore	Taper-Grip Alternative Hub Bore
B	30	25 1" 20 3/4"	40	35 1 1/4" 32	30	25
C	40	35 1 1/4" 32 30	50	42 45 1 3/4" 38	40	30
D	50	45 1 3/4" 42 1 1/2" 40 1 1/4" 38	55	2"	50	38
E	55	50 2" 45 1 3/4" 42 1 1/2"	65	60 2 1/4"	55	42
F	65	60 2 1/4" 55 2" 50	75	70 2 3/4" 2 1/2"	65	50
G	75	70 2 3/4" 65 2 1/2" 60 2 1/4"	85	80 3"	75	60
H	85	80 3" 75 2 3/4" 70 2 1/2"	100	85 95 3 1/2" 90	85	65
J	100	95 3 1/2" 90	120	110 4 1/2" 4"	100	80
S	120	110 4 1/2" 100 4" 90 3 1/2"	125	110 4 1/2" 100 4" 90 3 1/2"	120	90
T	125	110 4 1/2" 100 4" 90 3 1/2"	135		125	100
K	125	110 4 1/2" 100 4" 90 3 1/2"	-		125	100
L	150	130 5 1/2" 125 5" 100 4 1/2"	-		150	130
M	190*		-		190	130

All dimensions in millimetres unless otherwise stated.

(1) STANDARD HUB BORES

Metric hubs are bored to F7 limits, Inch hubs are bored to H7 limits.

A shaft tolerance grade h7 is recommended.

Shaft keyways must be appropriate standard dimensions, i.e. to BS 4235 for "metric" shafts and BS 46 for "inch" shafts.

* Max Hub bore size M reducer is 190mm, smaller bores are available to customer requirements — consult your local Authorised Distributor

† The alternative hub bore is the maximum bore available in each unit size.

(2) TAPER-GRIP™ HUB BORES

Shaft with tolerances up to h11 can be accommodated.

AGMA output hubs conforming to North American standards are available. Consult your local Authorised Distributor.

STANDARD HUB KEYWAYS

Keyways for the standard Output Hubs and Bushes are machined in accordance with BS 4235 for metric shafts and BS 46 for "inch" shafts.

Keys are supplied with reduction bushes, but not where the output hub directly fits the shaft.

Reduction bushes may be supplied with two separate keys for hub and shaft or a single stepped key, depending on the bush wall thickness.

The shaft keyway should be machined to suit the standard key size shown below, regardless of the hub bore diameter.

Shaft Diameter (mm)	Key size
20	6 x 6
25	8 x 7
30	8 x 7
32	10 x 8
35	10 x 8
38	10 x 8
40	12 x 8
42	12 x 8
45	14 x 9
50	14 x 9
55	16 x 10
60	18 x 11
65	18 x 11
70	20 x 12
75	20 x 12
80	22 x 14
85	22 x 14
90	25 x 14
95	25 x 14
100	28 x 16
110	28 x 16
120	32 x 18
125	32 x 18
130	32 x 18
140	36 x 20
150	36 x 20
190	45 x 25

Shaft Diameter (inches)	Key size
3/4"	3/16" x 3/16"
1"	1/4" x 1/4"
1 1/4"	5/16" x 1/4"
1 1/2"	3/8" x 1/4"
1 3/4"	7/16" x 5/16"
2"	1/2" x 5/16"
2 1/4"	5/8" x 7/16"
2 1/2"	5/8" x 7/16"
2 3/4"	3/4" x 1/2"
3"	3/4" x 1/2"
3 1/2"	7/8" x 5/8"
4"	1 x 3/4"
4 1/2"	1 1/4" x 7/8"
5"	1 1/4" x 7/8"
5 1/2"	1 1/2" x 1"

DIMENSIONS—SHAFT AND FLANGE MOUNTING

B - T

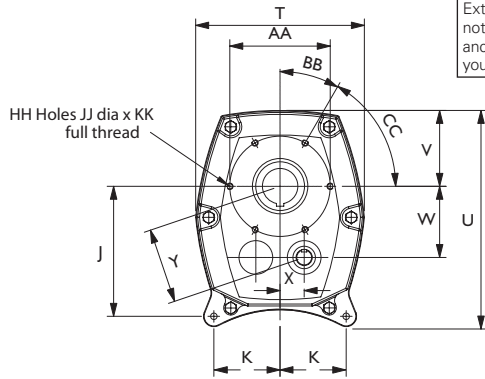

FLANGE MOUNTED

Extra case bolts are present on sizes J, S + T but are not detailed on these drawings, however Torque Arm anchorage points are as dimensioned. If in doubt consult your local Authorised Distributor

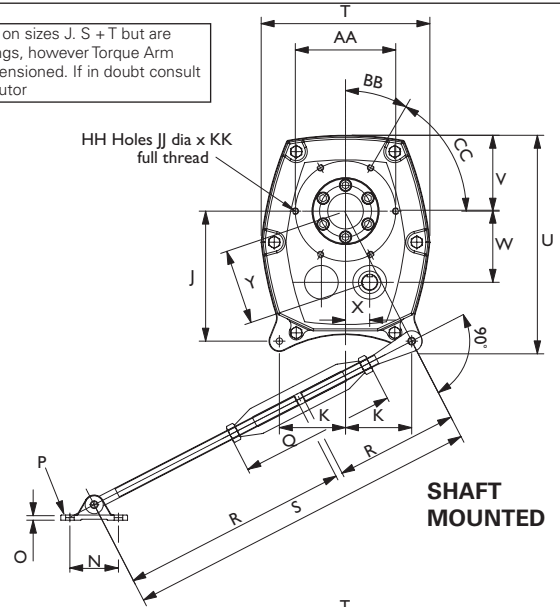

SHAFT MOUNTED

K - L - M

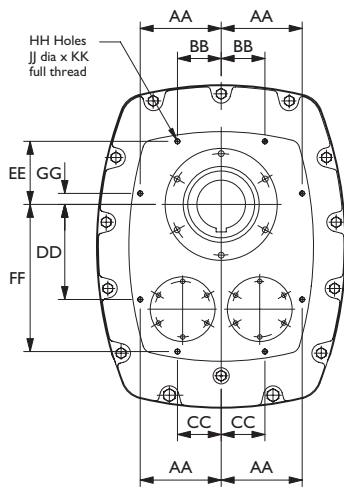

FLANGE MOUNTED

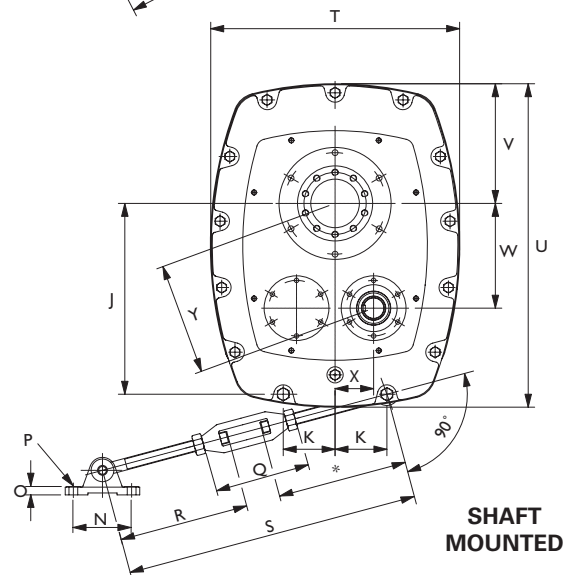

SHAFT MOUNTED

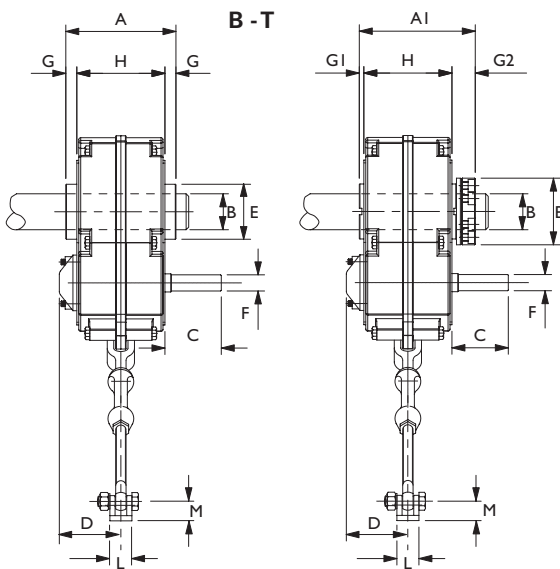

STANDARD HUB

TAPER-GRIP™ HUB

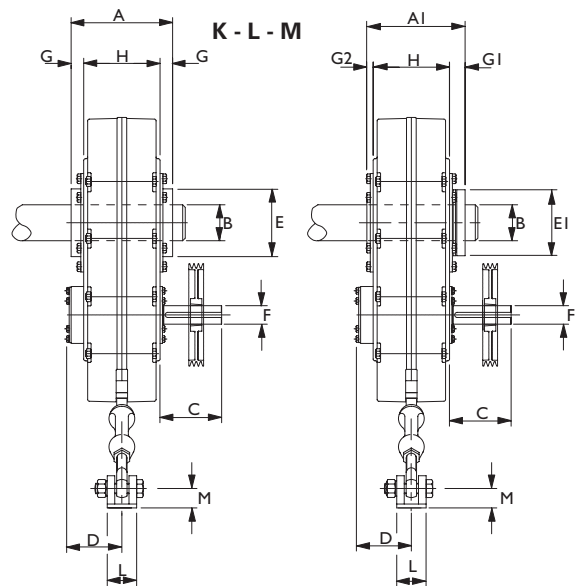

STANDARD HUB

TAPER-GRIP™ HUB

* On size L only this dimension is 375mm



DIMENSIONS – SHAFT AND FLANGE MOUNTING

Dimension	SMSR Size												
	B	C	D	E	F	G	H	J	S	T	K	L	M
A	117	152	161	173	195	214	255	275	290	312	310	356	406
A1	138	162	170	184	201	231	261	272	278	290	297	345	395
B	See Output Hub Dimensions Table on Page 277												
C	61	73	82	87	95	100	115	126	145	180	186	216	241
D	65	82	93	95	108	114	127	132	123	132	196	203	225
E	74	82	92	104	114	138	152	170	186	207	218	238	278
E1	55	65	75	85	100	110	130	150	160	180	207	232	276
F	19	19	22	25	28	32	42	48	55	60	60	65	85
G	11	17	17	19	20	20	26	30	35	44	44	44	44
G1	7	7	7	7	7	7	7	7	7	7	21	22	22
G2	36	37	36	42	39	50	51	50	51	59	54	55	55
H	95	118	127	135	155	174	203	215	220	224	222	268	318
J	144	137	169	201	238	261	294	353	456	519	513	590	677
K	63	75	84	102	121	133	152	145	157	160	102	160	190
L	24	24	28	28	34	34	70	70	70	70	70	110	110
M	20	20	24	24	30	30	50	50	50	50	51	76	76
N	65	65	75	75	100	100	120	120	120	120	120	180	180
O	5	5	8	8	12	12	18	18	18	18	18	26	26
P	10	10	13	13	17	17	16	16	16	16	M16	M24	M24
Q	200	200	216	216	216	216	222	222	222	222	222	265	265
R	300	300	350	350	375	375	375	375	375	375	375	400	400
S†	Max.	600	600	700	700	750	750	750	750	750	750	775	800
	Min.	750	750	850	850	900	900	900	900	900	900	925	950
T	160	186	218	258	278	317	365	434	542	568	643	770	880
U	208	234	282	330	385	421	477	570	734	814	841	1000	1140
V	72	81	96	117	129	143	162	195	254	281	298	370	410
W	66	75	90	110	125	141	156	189	255	267	280	324	373
X	24	25	31	37	43	50	56	62	75	92	100	119	133
Y	70	79	95	116	133	150	166	200	266	282	297	345	396
AA	106	120	135	155	175	212	255	280	280	320	208	250	315
BB	45°	45°	45°	30°	30°	30°	0°	0°	22.5°	22.5°	60	135	130
CC	90°	90°	90°	60°	60°	60°	60°	45°	45°	45°	60	135	130
DD	-	-	-	-	-	-	-	-	-	-	227	294	280
EE	-	-	-	-	-	-	-	-	-	-	176	195	215
FF	-	-	-	-	-	-	-	-	-	-	413	455	535
GG*	-	-	-	-	-	-	-	-	-	-	-19	34	-40
JJ	M8	M10	M10	M10	M12	M16	M20	M20	M20	M20	M16	M16	M16
HH	4	4	4	6	6	6	5	7	8	8	8	8	8
KK	15	15	15	15	18	24	30	30	30	30	27	27	27
Weight (kg)	single	10	14	19	29	41	64	84	122	179	242		
	double	11	15	21	31	45	69	92	133	197	268	385	545

All dimensions are in millimetres. Keyways are British Standard metric.

* Measured in the direction of DD.

† Permits 150mm adjustment to tighten V-Belts. By cutting off threaded end of rods dimension 'S' may be reduced by up to 300mm sizes B & C, 350mm on sizes D & E, 395mm on sizes F, G, H, J & S, 300mm on size K, 330mm on size L, 335mm on size M.

EXACT GEAR RATIOS

Nominal ratio	B	C	D	E	F	G	H	J	S	T	K	L	M
5:1	5.091	4.941	5.300	5.047	5.047	5.047	5.047	5.047	5.047	4.684	-	-	-
13:1	13.315	13.410	14.268	13.587	13.587	13.395	13.587	13.587	13.587	13.644	13.270	13.260	12.850
20:1	20.095	20.421	21.481	20.455	20.455	20.455	20.455	20.455	20.455	20.113	19.970	19.580	19.330
25:1	-	23.544	25.600	25.235	25.235	25.235	25.235	25.235	25.235	23.654	24.000	24.733	22.601

NEW UP-RATED TAPER-GRIP™ LOCKING SYSTEM

Fenner Shaft Mounted Speed Reducers can be secured to the driven shaft by a unique bush locking system which overcomes the difficulties experienced with other methods of mounting, particularly in corrosive environments.

The new design includes cap head screws for higher tightening torques and a hardened steel thrust plate. These two new features are responsible for part of the significant torque increase.

UP-RATED TAPER-GRIP

- Transmits 300% more torque
- Accommodates shaft tolerances to h11
- Standard bores require no key
- Accessible locking arrangement
- Reversible bush assembly
- Resistant to fretting corrosion
- Even easier removal of gear unit

Assembly

After the bush is screwed into the hub the reducer can be conveniently positioned on the driven shaft. Locking is effected by sequential tightening of the screws which draw the bush axially against the opposing tapers in the hub thus generating the clamping force along the whole length of the bush in contact with the shaft.

Removal

The Taper-Grip system offers significant advantages when removing the reducer from the shaft.

There is a tendency for Shaft Mounted Reducers, subject to atmospheric or fretting corrosion, to seize solidly onto the shaft, making removal difficult and time-consuming.

The Taper-Grip system eliminates this problem, the bush is manufactured from spheroidal graphite iron which not only has similar mechanical properties to steel but has a natural resistance to corrosion and a degree of self-lubricity.

This combination of dissimilar materials in contact alleviates fretting corrosion and when the bush screws are loosened and the tapers released there is sufficient clearance within the assembly to permit easy removal.

Because the bush is screwed into the hub it is inherently safe. Even if the locking screws are completely removed it cannot inadvertently fall out during reducer handling.

Use of smaller than standard bores on Taper-Grip bushes

For applications where it is desirable to fit Taper-Grip bushes with bores smaller than the standard catalogue sizes, depending on the size, the torque capacity of the bush may be below the quoted catalogue ratings. In these situations it is preferable to fit a key to the bush/shaft interface. In these cases please consult your local Authorised Distributor.

TRANSMITS 300% MORE TORQUE

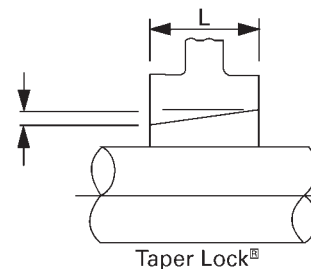

Taper Lock®

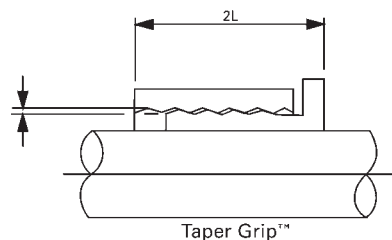

Taper Grip™

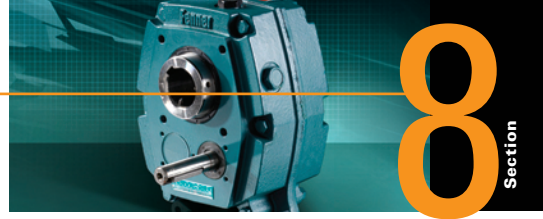

Ordering Instructions

GEARBOX CODING

The required unit is identified by an eight digit code as under:

First Three Digits:	Product Prefix	Constant 116
Fourth Digit:	Unit Size	B C D E F G H J S T K L M
Fifth and Sixth Digits:	Ratio Code	05. 13. 20 & 25
Seventh Digit:	Indicates Assembly	0 Shaft Mounted Speed Reducer
Eighth Digit:	Indicates Output Hub bore required	1 Standard Metric bore † 2 Upper Alternative Metric bore † 5 Taper-Grip Hub

† The hub bushes in the table opposite can be used in all three parallel hub bore options.

Example

Size G Unit 20:1 nominal Gear Ratio. shaft mounted with standard Metric Hub Bore (75mm) 116G2001.
If Backstop or Output Bushes are required, these should be ordered separately.
e.g. 116G2001 complete with Backstop and 60 mm Output Hub Bushes.

TAPER-GRIP CODING

Taper-Grip units are supplied without the Taper-Grip Bush. These should be ordered separately, see table below.

First Three Digits:	Product Prefix	012 Metric bores	013 Inch bores
Fourth Digit:	Unit Size	B C D E F G H J S T K L M	
Fifth Digits:	Constant	1	
Sixth, Seventh and Eighth Digit:	Indicates Taper-Grip bore size in millimetres or inches	Metric Bore	Bore Code
		Inch Bore	Bore Code
		25	025
		30	030
		35	035
		40	040
		45	045
		50	050
		55	055
		60	060
		65	065
		75	075
		85	085
		90	090
		100	100
		120	120
		125	125
		130	130
		150	150
		190	190

Example

Size G Unit 20:1 nominal Gear Ratio. shaft mounted with Metric Taper-Grip Bore (75 mm). SMSR code is 116G2005.
Taper-Grip bush code is 012G1075.

BACKSTOP CODING

The required backstop size is identified by an eight digit code:

First Three Digits:	Product Prefix	044
Fourth Digit:	Unit Size	B, C, D, E, F, G, H, J, S, T, K, L, M
Fifth, Sixth, Seventh & Eight Digit:	Product Suffix	0003

Example: 044G0003 - Size G PowerPlus backstop

OPTIONAL EXTRAS

Backstops

Incorporated to prevent reversal of rotation. Quickly installed within the reducer, by simply removing a cover plate.

Flange Mounting

All gear cases now have drilled and tapped holes in the input drive face for bolting direct to a supporting framework. This flange mounting use of the reducer eliminates a bearing or pillow block. However the belt adjustment feature of shaft mounting is also lost, see page 287.

Reversing Duty

Shaft Mounted Speed Reducers suitable for reversing duty can be supplied to order.

Vertical Shafts

Units suitable for mounting on vertical shafts can be supplied at extra charge. When ordering, please specify whether input shaft is above or below.

AGMA Output Hubs

Bores conforming to North American standards are available.

Screw Conveyors

Screw conveyor adaptors conforming to CEMA mounting specifications are available.

SMSR PARALLEL HUB BUSHES

HUB. DIA mm	SMSR SIZE		SHAFT DIA.		BUSH CODE
	Alt.	Std.	inch	mm	
30	-	B	0.75	-	016A9106
30	-	B	-	20	016A9220
30	-	B	-	25	016A9225
30	-	B	1.00	-	016A9110
40	-	C	-	30	016C9230
40	B	C	1.25	-	016B9112
50	-	D	1.25	-	016D9112
40	B	C	-	32	016B9232
40	B	C	-	35	016B9235
50	C	D	-	38	016C9238
50	C	D	1.50	-	016C9114
55	-	E	1.50	-	016E9114
50	-	D	-	40	016D9240
50	C	D	-	42	016C9242
55	-	E	-	42	016E9242
50	C	D	1.75	-	016C9116
55	-	E	1.75	-	016E9116
50	C	D	-	45	016C9245
55	-	E	-	45	016E9245
55	-	E	-	50	016E9250
65	-	F	-	50	016F9250
55	D	E	2.00	-	016D9120
65	-	F	2.00	-	016F9120
65	-	F	-	55	016F9255
65	E	F	2.25	-	016E9122
75	-	G	2.25	-	016G9122
65	E	F	-	60	016E9260
75	-	G	-	60	016G9260
75	F	G	2.50	-	016F9124
85	-	H	2.50	-	016H9124
75	-	G	-	65	016G9265
75	F	G	2.75	-	016F9126
85	-	H	2.75	-	016H9126
75	F	G	-	70	016F9270
85	-	H	-	70	016H9270
85	-	H	-	75	016H9275
85	G	H	3.00	-	016G9130
85	G	H	-	80	016G9280
100	H	J	-	85	016H9285
100	H	J	3.50	-	016H9134
120	-	S	3.50	-	016S9134
125	-	T/K	3.50	-	016K9134
100	H	J	-	90	016H9290
120	-	S	-	90	016S9290
125	S	T/K	-	90	016K9290
100	H	J	-	95	016H9295
120	-	S	-	100	016S9200
125	S	T/K	-	100	016K9200
150	-	L	-	100	016L9200
120	J	S	4.00	-	016J9140
125	S	T/K	4.00	-	016K9140
120	J	S	-	110	016J9210
125	S	T/K	-	110	016K9210
120	J	S	4.50	-	016J9144
125	S	T/K	4.50	-	016K9144
150	-	L	4.50	-	016L9144
150	-	L	-	125	016L9225
150	-	L	5.00	-	016L9150
150	-	L	-	130	016L9230
150	-	L	5.50	-	016L9154

BELT DRIVES – 1440 REV/MIN MOTORS

UNIT SIZE B						
	Nominal Output Speed	Pulley Ratio	Pulley Pitch diameters		Number of belts	
			Motor	Gearbox		
20:1	10	7.14	56	400	1XPZ	
	12	5.97	67	400	1SPZ	
	14	5.00	63	315	1SPZ	
	16	4.44	71	315	1SPZ	
	18	3.94	80	315	1SPZ	
	20	3.57	56	200	1XPZ	
	22	3.21	56	180	1XPZ	
	24	2.86	63	180	1XPZ	
	26	2.78	90	250	1SPZ	
	28	2.54	63	160	1SPZ	
	30	2.36	56	132	1XPZ	
	32	2.22	63	140	1SPZ	
	34	2.10	63	132	1SPZ	
	38	1.87	67	125	1SPZ	
	40	1.78	63	112	1XPZ	
	42	1.70	56	95	2XPZ	
	46	1.56	90	140	1SPZ	
	50	1.43	112	160	1SPZ	
52	1.39	90	125	1SPZ		
54	1.33	75	100	1SPZ		
58	1.24	95	118	1SPZ		
62	1.16	140	160	1SPZ		
66	1.64	63	67	2SPZ		
13:1	66	1.64	85	140	1SPZ	
	70	1.55	85	132	1SPZ	
	74	1.46	90	132	1SPZ	
	78	1.39	90	125	1SPZ	
	80	1.35	63	85	2XPZ	
	85	1.28	125	160	1SPZ	
	90	1.20	75	90	2SPZ	
	100	1.08	90	100	1QXPA	
	5:1	100	2.83	112	315	1SPZ
		110	2.57	95	250	1XPA
120		2.36	106	250	1XPZ	
130		2.18	112	250	1XPZ	
140		2.02	125	250	1SPZ	
150		1.88	85	160	2SPZ	
160		1.76	85	150	2XPA	
170		1.67	75	125	3SPZ	
180		1.57	75	118	3SPZ	
190		1.49	95	140	2SPZ	
200		1.42	106	150	1QXPA	
210		1.35	112	150	1QXPA	
220		1.29	140	180	1SPA	
230		1.23	132	160	1SPA	
240		1.18	95	112	2SPZ	
250		1.13	160	180	1XPZ	
260		1.09	140	150	1SPA	
270		1.05	95	100	2SPA	
280		1.01	112	112	2SPZ	
300		1.06	140	132	1XPA	
310		1.11	200	180	1XPZ	
320		1.14	150	132	1XPA	
330		1.18	100	85	3SPZ	
340		1.20	150	125	1QXPA	
350	1.24	118	95	2XPA		
360	1.27	400	315	1XPZ		
370	1.31	236*	180*	1SPB		
380	1.36	160	118	1QXPA		
390	1.39	250	180	1SPZ		
400	1.41	315	224	1SPA		

UNIT SIZE C					
	Nominal Output Speed	Pulley Ratio	Pulley Pitch diameters		Number of belts
			Motor	Gearbox	
20:1	10	7.04	71	500*	1SPZ
	12	5.63	71	400	1SPZ
	14	5.00	80	400	1SPZ
	15	4.44	71	315	1SPZ
	17	3.94	80	315	1SPZ
	20	3.50	90	315	1SPZ
	22	3.13	80	250	1SPZ
	24	2.94	85	250	1SPZ
	26	2.69	67	180	1SPZ
	28	2.40	75	180	1XPZ
	30	2.25	71	160	1XPZ
	32	2.13	75	160	1XPZ
	34	2.00	80	160	1XPZ
	38	1.80	100	180	1SPA
	40	1.70	106	180	1SPZ
	42	1.65	85	140	1XPZ
	46	1.50	100	150	1SPA
	50	1.36	118	160	1XPZ
52	1.32	106	140	1XPZ	
54	1.29	140	180	1XPZ	
58	1.18	100	118	1XPA	
62	1.11	90	100	2SPZ	
13:1	66	1.56	90	140	2SPZ
	70	1.47	85	125	2SPZ
	74	1.39	95	132	2SPZ
	78	1.32	106	140	1XPA
	80	1.28	125	160	1SPZ
	85	1.21	140	170	1XPZ
	90	1.14	140	160	2SPZ
	95	1.07	75	80	3XPZ
	100	1.00	100	100	2SPZ
	5:1	101	2.86	140	400
114		2.52	125	315	1XPA
121		2.39	132	315	1XPA
129		2.23	112	250	2SPZ
144		2.00	140	280	1XPA
152		1.90	118	224	2SPA
161		1.79	140	250	1XPA
171		1.68	95	160	3SPZ
183		1.58	200	315	1XPZ
193		1.49	150	224	2SPA
202		1.43	112	160	2SPZ
211		1.36	132	180	2SPZ
224		1.29	140	180	2SPZ
230		1.25	160	200	2XPZ
244		1.18	100	118	3XPZ
252		1.14	140	160	2SPZ
259		1.11	180	200	1SPA
273		1.06	125	132	2SPZ
288		1.00	140	140	2SPA
303		1.05	100	95	2SPA
310		1.08	140	130	3SPZ
324		1.13	180	160	2SPZ
329		1.14	140	160	3SPA
339		1.18	200	170	2SPA
349	1.21	160	132	2SPA	
360	1.25	140	112	3SPZ	
369	1.28	180	140	2XPZ	
380	1.32	150	112	2XPA	
391	1.36	180	132	2XPA	
400	1.39	140	100	3XPA	

UNIT SIZE D					
	Nominal Output Speed	Pulley Ratio	Pulley Pitch diameters		Number of belts
			Motor	Gearbox	
20:1	10	1.04	71	500	1XPZ
	12	5.63	71	400	1SPZ
	14	4.70	67	315	1SPZ
	16	4.20	75	315	1SPZ
	18	3.71	85	315	1SPZ
	20	3.29	85	280	1SPZ
	22	3.11	90	280	1SPA
	24	2.78	90	250	1SPZ
	26	2.54	63	160	2XPZ
	28	2.39	67	160	2SPZ
	30	2.24	100	224	1XPA
	32	2.11	95	200	1XPA
	34	1.97	160	315	1SPZ
	38	1.76	75	132	2XPZ
	40	1.68	95	160	2SPZ
	42	1.60	125	200	1XPZ
	46	1.47	90	132	2SPZ
	50	1.34	112	150	2SPA
52	1.29	140	180	1XPZ	
54	1.24	95	118	2SPZ	
58	1.14	140	160	1SPA	
62	1.07	140	150	1XPA	
13:1	66	1.52	132	200	1SPA
	71	1.43	112	160	2XPZ
	74	1.36	118	160	2SPZ
	78	1.29	140	180	1XPA
	80	1.25	112	140	2XPZ
	85	1.19	118	140	2SPZ
	90	1.12	125	140	2SPZ
	95	1.06	132	140	2SPZ
	100	1.00	125	125	2XPZ
	5:1	108	2.52	125	315
114		2.39	132	315	2SPZ
120		2.25	140	315	2SPZ
130		2.11	112	236	2XPB
140		1.90	118	224	2XPA
150		1.80	118	212	2XPB
160		1.69	118	200	3XPZ
170		1.60	125	200	3SPZ
180		1.52	132	200	3SPZ
190		1.43	140	200	3SPZ
200		1.36	132	180	2XPA
210		1.29	140	180	2SPA
220		1.21	132	160	3SPZ
230		1.18	112	132	4XPZ
240		1.12	112	125	4XPZ
250		1.07	140	150	3SPA
260		1.05	112	118	4XPZ
270		1.00	140	140	3XPZ
285		1.05	100	95	4QXPA
290		1.07	160	150	2XPA
300		1.11	200	180	2QXPZ
310		1.14	160	140	3SPZ
320		1.18	132	112	4XPZ
330		1.21	160	132	3SPA
340	1.25	250	200	2XPZ	
350	1.29	180	140	3XPZ	
360	1.32	140	106	5SPZ	
370	1.36	190	140	2XPB	
380	1.40	140	100	4XPA	
390	1.44	180	125	3XPA	
400	1.47	250	170	2XPB	

* Pulley only available in 2 groove.

For 25:1 reduction SMSR belt drives consult your local Authorised Distributor



BELT DRIVES – 1440 REV/MIN MOTORS

UNIT SIZE E					
	Nominal Output Speed	Pulley Ratio	Pulley Pitch diameters		Number of belts
			Motor	Gearbox	
20:1	10	7.04	71	500	2SPZ
	12	5.97	67	400	2SPZ
	14	5.00	80	400	2SPZ
	16	4.44	90	400	1XPZ
	18	4.00	100	400	2SPZ
	20	3.50	90	315	2SPZ
	22	3.15	100	315	2SPZ
	24	2.94	85	250	2XPZ
	26	2.67	75	200	2XPZ
	28	2.50	80	200	3SPZ
	30	2.35	85	200	2SPZ
	32	2.22	90	200	2XPZ
	34	2.09	67	140	4XPZ
	38	1.87	150	280	1SPA
	40	1.75	80	140	3XPZ
	42	1.68	95	160	3SPZ
46	1.52	132	200	2SPZ	
50	1.42	106	150	2XPA	
52	1.36	118	160	3SPZ	
54	1.29	140	180	2XPZ	
58	1.21	132	160	2XPZ	
62	1.14	132	150	2SPA	
13:1	66	1.61	112	180	3SPZ
	70	1.52	132	200	3XPZ
	74	1.43	112	160	3XPZ
	78	1.36	118	160	3SPZ
	80	1.32	100	132	3XPA
	85	1.25	100	125	4XPZ
	90	1.18	106	125	4XPZ
	95	1.11	106	118	4XPZ
	100	1.06	132	140	3XPZ
	101	2.86	140	400	3SPZ
114	2.52	125	315	4SPZ	
121	2.39	132	315	3XPZ	
129	2.23	112	250	5XPA	
144	2.00	125	250	3SPA	
152	1.90	118	224	4SPA	
161	1.79	140	250	3SPA	
171	1.69	140	236	2QXPB	
183	1.58	200	315	3XPZ	
193	1.49	150	224	3SPA	
202	1.43	112	160	4XPA	
211	1.36	132	180	4SPA	
224	1.29	140	180	3XPA	
230	1.25	200	250	2XPA	
244	1.18	190	224	2XPB	
252	1.14	140	160	4SPA	
259	1.11	180	200	2XPB	
273	1.06	125	132	5SPA	
288	1.00	160	160	3XPA	
303	1.05	200	190	2XPB	
310	1.08	140	132	4XPA	
324	1.13	180	160	3XPA	
329	1.14	160	140	4XPA	
342	1.19	140	118	5XPA	
349	1.21	160	132	4XPA	
360	1.25	140	112	6XPA	
370	1.29	180	140	4XPA	
386	1.34	150	112	6XPA	
393	1.36	180	132	5XPA	
403	1.40	224	160	3XPA	

UNIT SIZE F					
	Nominal Output Speed	Pulley Ratio	Pulley Pitch diameters		Number of belts
			Motor	Gearbox	
20:1	10	7.00	90	630*	1SPA
	12	5.97	67	400	2SPZ
	14	5.00	100	500*	1SPA
	16	4.44	90	400	2SPZ
	18	3.94	80	315	2SPZ
	20	3.57	112	400	1XPA
	22	3.20	125	400	1SPA
	24	2.94	85	250	3SPZ
	26	2.67	150	400	1SPA
	28	2.50	160	400	1SPA
	30	2.35	85	200	3XPZ
	32	2.22	90	200	3SPZ
	33	2.11	95	200	3SPZ
	37	1.88	85	160	4SPZ
	40	1.75	180	315	1XPA
	42	1.67	150	250	2SPA
46	1.53	118	180	3SPZ	
48	1.47	95	140	4XPZ	
50	1.40	100	140	4SPZ	
52	1.36	118	160	3XPZ	
55	1.29	140	180	3SPZ	
63	1.12	112	125	4SPZ	
66	1.07	150	160	2XPA	
13:1	70	1.52	132	200	4SPZ
	74	1.43	140	200	2XPB
	78	1.36	118	160	4SPA
	80	1.32	170	224	2SPB
	85	1.24	180	224	2SPA
	90	1.18	170	200	2SPB
	95	1.11	180	200	3SPZ
	100	1.06	132	140	5SPZ
	102	2.81	160	450	2SPB
	109	2.63	190	500	2SPB
121	2.39	132	315	5SPZ	
128	2.25	140	315	4SPA	
144	2.00	125	250	4SPA	
152	1.89	132	250	5XPZ	
161	1.79	140	250	5SPZ	
172	1.67	212	355	2SPB	
183	1.58	200	315	4SPZ	
193	1.49	150	224	4SPA	
202	1.43	140	200	4XPA	
212	1.36	140	190	4SPB	
224	1.29	140	180	4SPB	
231	1.24	180	224	3XPA	
243	1.19	236	280	2XPB	
252	1.14	140	160	5XPA	
259	1.11	180	200	3SPB	
272	1.06	236	250	2XPB	
288	1.00	315	315	2XPA	
303	1.05	200	190	3XPB	
309	1.07	150	140	5XPA	
323	1.12	224	200	3XPA	
329	1.14	160	140	5XPA	
342	1.19	280	236	2XPB	
358	1.24	236	190	3SPB	
365	1.27	355	280	2XPB	
384	1.33	315	236	2XPB	
405	1.41	315	224	3XPA	

UNIT SIZE G					
	Nominal Output Speed	Pulley Ratio	Pulley Pitch diameters		Number of belts
			Motor	Gearbox	
20:1	10	7.00	90	630	2SPA
	12	5.94	106	630	2SPA
	14	5.00	100	500	2SPA
	16	4.44	90	400	3SPZ
	18	4.00	100	400	2XPA
	20	3.57	112	400	2SPA
	22	3.20	125	400	2SPA
	24	2.94	85	250	4XPZ
	26	2.67	118	315	3SPZ
	28	2.50	160	400	2XPZ
	30	2.36	106	250	3XPA
	32	2.23	112	250	3SPA
	34	2.10	150	315	2SPA
	38	1.87	150	280	2XPA
	40	1.75	160	280	2XPA
	42	1.67	150	250	3SPA
46	1.52	132	200	4XPZ	
48	1.48	160	236	2XPB	
50	1.40	200	280	2XPA	
52	1.36	118	160	4XPA	
55	1.29	140	180	4SPA	
63	1.11	180	200	4XPZ	
66	1.07	150	160	4XPA	
13:1	70	1.52	132	200	5SPA
	74	1.43	140	200	4SPA
	78	1.36	140	190	4SPB
	80	1.32	212	280	2SPB
	85	1.24	180	224	3SPB
	90	1.18	180	212	3XPB
	95	1.11	180	200	3XPB
	100	1.06	200	212	3XPB
	102	2.81	160	450	4SPB
	109	2.63	190	500	3SPB
122	2.37	190	450	3SPB	
130	2.22	160	355	4SPB	
144	2.00	200	400	5XPZ	
153	1.89	212	400	3SPB	
162	1.78	200	355	3XPB	
172	1.67	212	355	3SPB	
183	1.58	200	315	4SPA	
191	1.50	236	355	3XPB	
202	1.43	280	400	3XPA	
212	1.36	140	190	6XPB	
220	1.31	180	236	5SPB	
230	1.25	224	280	4XPA	
243	1.19	236	280	3XPB	
256	1.13	280	315	3XPB	
259	1.11	450	500	2XPB	
273	1.06	212	224	4XPB	
288	1.00	315	315	3XPA	
303	1.05	236	224	4XPB	
309	1.07	300	280	2QXPC	
323	1.12	224	200	4XPB	
326	1.13	300	265	3QXPC	
340	1.18	236	200	4XPB	
358	1.24	236	190	5SPB	

* Pulley only available in 2 groove.

For 25:1 reduction SMSR belt drives consult your local Authorised Distributor

BELT DRIVES – 1440 REV/MIN MOTORS

UNIT SIZE H						
	Nominal Output Speed	Pulley Ratio	Pulley Pitch diameters		Number of belts	
			Motor	Gearbox		
20:1	10	7.00	90	630	3SPA	
	12	5.94	106	630	3SPA	
	14	5.04	125	630	2SPA	
	16	4.44	90	400	4SPZ	
	18	4.00	100	400	3SPA	
	20	3.57	140	500	2XPA	
	22	3.20	125	400	2XPB	
	24	2.97	106	315	4SPA	
	26	2.67	150	400	2XPA	
	28	2.50	160	400	2XPA	
	30	2.35	170	400	2SPB	
	32	2.23	112	250	4XPA	
	34	2.10	150	315	3SPA	
	38	1.85	170	315	2XPB	
	40	1.75	160	280	3SPA	
	42	1.67	150	250	4SPA	
	46	1.52	132	200	5SPA	
	48	1.48	160	236	3SPB	
50	1.40	200	280	3XPA		
52	1.36	118	160	6XPA		
55	1.29	140	180	5SPA		
60	1.18	180	212	3XPB		
63	1.12	200	224	3XPA		
66	1.06	200	212	3XPB		
13:1	70	1.50	236	355	2XPB	
	74	1.43	280	400	3XPA	
	78	1.36	140	190	6SPB	
	80	1.32	212	280	3SPB	
	85	1.24	180	224	5SPA	
	90	1.18	190	224	4SPB	
	95	1.11	212	236	3XPB	
	100	1.06	200	212	4XPB	
	5:1	101	2.81	224	630	3SPB
		108	2.63	190	500	4SPB
120		2.37	190	450	4XPB	
128		2.23	224	500	4XPA	
143		2.00	200	400	5SPA	
151		1.89	212	400	4SPB	
160		1.79	224	400	5SPA	
172		1.66	190	315	5SPB	
180		1.58	224	355	4SPB	
190		1.50	236	355	4XPB	
200		1.43	280	400	3XPB	
213		1.34	224	300	4SPC	
218		1.31	180	236	6SPB	
228		1.25	224	280	6SPA	
240		1.19	236	280	5XPB	
253		1.13	315	355	3XPB	
257		1.11	450	500	3XPB	
269		1.06	236	250	5XPB	
285	1.00	280	280	4XPB		
301	1.05	236	224	6XPB		
306	1.07	300	280	3QXPC		
321	1.13	315	280	4XPB		
323	1.13	425	375	3QXPC		
339	1.19	280	236	5XPB		

For 25:1 reduction SMSR belt drives consult your local Authorised Distributor

UNIT SIZE J					
	Nominal Output Speed	Pulley Ratio	Pulley Pitch diameters		Number of belts
			Motor	Gearbox	
20:1	10	7.00	90	630	4SPA
	12	5.94	106	630	3SPA
	14	5.00	100	500	4SPA
	16	4.50	140	630	2SPB
	18	3.94	160	630	2SPA
	20	3.57	140	500	3SPA
	22	3.20	125	400	4SPA
	24	2.95	190	560	2SPB
	26	2.67	150	400	3XPA
	28	2.50	160	400	3XPA
	30	2.36	212	500	2SPB
	32	2.22	180	400	3SPA
	34	2.10	150	315	4XPA
	38	1.87	190	355	3SPB
	40	1.75	180	315	4SPA
	42	1.66	190	315	3SPB
	46	1.50	200	300	3SPC
	50	1.41	224	315	3XPA
52	1.33	236	315	3SPB	
54	1.31	180	236	4SPB	
58	1.21	140	170	6XPB	
62	1.13	315	355	2SPB	
67	1.06	212	224	4SPB	
13:1	67	1.58	200	315	5SPA
	70	1.50	236	355	3SPB
	74	1.43	280	400	3XPA
	78	1.35	315	425	3SPC
	80	1.32	212	280	4SPB
	85	1.24	190	236	6SPB
	90	1.18	212	250	4XPB
	95	1.12	224	250	5XPA
	100	1.06	236	250	4SPB
	5:1	100	2.86	280	800
110		2.63	190	500	6SPB
120		2.38	265	630	3SPC
130		2.22	450	1000	2QXPB
140		2.01	236	475	4SPC
150		1.91	236	450	5SPB
160		1.79	280	500	5SPA
170		1.68	315	530	3SPC
180		1.59	315	500	5SPA
190		1.50	250	375	5SPC
200		1.43	280	400	6SPA
210		1.35	315	425	3SPC
220		1.32	190	250	8XPB
230		1.24	190	236	8XPB
240		1.19	315	375	4SPC
250		1.13	375	425	3SPC
260		1.11	180	200	8QXPB
270		1.06	212	224	8XPB
290	1.00	400	400	5SPA	
300	1.05	236	224	8XPB	
310	1.07	300	280	5SPC	
320	1.12	265	236	6SPC	
330	1.18	212	180	8XPB	
340	1.19	315	265	4SPC	
350	1.24	236	190	8SPB	
360	1.26	315	250	6SPA	
370	1.31	236	180	8SPB	
380	1.33	315	236	5SPB	
390	1.39	250	180	6XPB	
400	1.41	315	224	6XPA	

UNIT SIZE S					
	Nominal Output Speed	Pulley Ratio	Pulley Pitch diameters		Number of belts
			Motor	Gearbox	
20:1	10	7.14	112	800	3XPB
	12	5.94	106	630	4SPA
	14	5.00	160	800	3SPB
	16	4.50	140	630	3SPA
	18	3.94	160	630	3SPA
	20	3.57	140	500	3XPB
	22	3.20	125	400	5SPA
	24	2.97	212	630	2SPB
	26	2.67	150	400	4XPA
	28	2.50	160	400	4SPB
	30	2.36	212	500	3SPB
	32	2.22	180	400	4SPA
	34	2.09	170	355	5SPB
	38	1.87	190	355	4SPB
	40	1.75	180	315	5SPA
	42	1.67	212	355	4SPB
	46	1.50	236	355	3SPC
	50	1.41	224	315	4XPA
52	1.32	212	280	4XPB	
54	1.31	180	236	5XPB	
58	1.20	250	300	3SPC	
63	1.13	265	300	3SPC	
67	1.06	212	224	5SPB	
13:1	67	1.58	200	315	5SPB
	70	1.50	236	355	4XPB
	74	1.43	280	400	5XPA
	78	1.35	315	425	3SPC
	80	1.32	212	280	5XPB
	85	1.24	190	236	8SPB
	90	1.19	236	280	5SPB
	95	1.12	250	280	6XPA
	100	1.06	236	250	5XPB
	5:1	100	2.86	280	800
110		2.63	190	500	8SPB
120		2.38	265	630	4SPC
130		2.22	450	1000	3SPB
140		2.01	236	475	4QXPC
150		1.91	236	450	6XPB
160		1.79	280	500	6SPB
170		1.68	375	630	3SPC
180		1.59	315	500	5SPB
190		1.50	300	450	5SPC
200		1.43	280	400	6XPB
210		1.35	315	425	5SPC
220		1.32	425	560	3SPC
230		1.25	425	530	3SPC
240		1.19	315	375	5SPC
250		1.13	375	425	4SPC
260		1.11	450	500	4QXPB
270		1.06	265	280	8SPC
290	1.00	355	355	6XPB	
300	1.06	375	355	4QXPC	
310	1.07	400	375	4SPC	
320	1.12	375	335	5SPC	
330	1.18	500	425	3QXPC	
340	1.19	375	315	5SPC	
350	1.24	236	190	8QXPB	
360	1.26	315	250	6SPC	
370	1.31	236	180	8QXPB	
380	1.33	315	236	6XPB	
390	1.35	425	315	3QXPC	
400	1.40	280	200	8SPB	

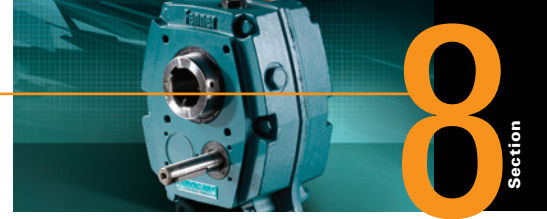

BELT DRIVES – 1440 REV/MIN MOTORS

UNIT SIZE T					
	Nominal Output Speed	Pulley Ratio	Pulley Pitch diameters		Number of belts
			Motor	Gearbox	
20:1	10	7.14	140	1000	3SPB
	12	5.71	140	800	3SPB
	14	5.04	125	630	4SPA
	16	4.50	140	630	4SPA
	18	3.94	160	630	3SPB
	20	3.50	180	630	3SPB
	22	3.15	200	630	4SPA
	24	2.97	212	630	3SPB
	26	2.67	236	630	3SPB
	28	2.50	200	500	3XPB
	30	2.36	212	500	3XPB
	32	2.22	180	400	5SPA
	34	2.09	170	355	6SPB
	38	1.87	190	355	5SPB
	40	1.79	224	400	5SPA
	42	1.67	212	355	4XPB
	46	1.52	280	425	3SPC
	50	1.41	224	315	6SPA
52	1.33	236	315	5XPB	
54	1.31	180	236	6QXPB	
58	1.24	190	236	6XPB	
63	1.13	265	300	4SPC	
67	1.06	236	250	5XPB	
13:1	67	1.58	200	315	6XPB
	70	1.50	236	355	5XPB
	74	1.43	280	400	6XA
	78	1.35	315	425	3QXPC
	80	1.32	425	560	3SPC
	84	1.25	400	500	5SPA
	90	1.18	425	500	3SPC
	95	1.11	212	236	8XPB
	100	1.06	355	375	3SPC
	5:1	100	3.11	180	560
110		2.81	224	630	8SPB
120		2.54	315	800	5QXPB
130		2.37	236	560	8SPB
140		2.22	450	1000	4QXPB
150		2.01	236	475	5QXPC
160		1.91	236	450	8QXPB
170		1.78	450	800	5SPB
180		1.68	375	630	4SPC
190		1.61	280	450	8SPB
200		1.51	315	475	4QXPC
210		1.48	425	630	4SPC
220		1.42	335	475	5SPC
230		1.33	375	500	5SPC
240		1.27	315	400	8SPB
250		1.24	450	560	5QXPB
260		1.18	475	560	3QXPC
270		1.13	375	425	5SPC
280		1.11	450	500	3QXPC
290		1.06	335	355	6SPC
310		1.00	355	355	6XPB
320		1.05	315	300	6SPC
330		1.07	400	375	4SPC
340		1.11	500	450	4QXPB
350		1.13	425	375	3QXPC
360		1.18	250	212	8QXPB
370		1.20	450	375	3QXPC
380		1.24	236	190	8QXPB
390	1.27	355	280	6XPB	
400	1.32	250	190	8QXPB	

For 25:1 reduction SMSR belt drives consult your local Authorised Distributor

UNIT SIZE K					
	Nominal Output Speed	Pulley Ratio	Pulley Pitch diameters		Number of belts
			Motor	Gearbox	
20:1	10	7.14	140	1000	4SPB
	12	6.06	132	800	4XPB
	14	5.00	160	800	3SPB
	16	4.44	180	800	3SPB
	18	3.94	160	630	4SPB
	20	3.57	224	800	3SPB
	22	3.29	170	560	4SPB
	24	2.94	170	500	4XPB
	26	2.81	224	630	3SPB
	28	2.52	250	630	3SPB
	30	2.36	212	500	4SPB
	32	2.23	224	500	5SPA
	34	2.12	236	500	4SPB
	38	1.89	212	400	5SPB
	40	1.79	224	400	6SPA
	42	1.69	236	400	4XPB
	46	1.58	300	475	3SPC
	50	1.50	250	375	4SPC
52	1.40	400	560	3SPB	
54	1.33	236	315	5XPB	
58	1.25	400	500	3SPB	
13:1	62	1.75	180	315	8SPB
	65	1.67	300	500	4SPC
	70	1.56	180	280	8QXPB
	74	1.47	190	280	8SPB
	78	1.40	400	560	4SPB
	80	1.35	315	425	4SPC
	85	1.27	236	300	6SPC
	90	1.20	250	300	5SPC
	95	1.13	265	300	4SPC
	100	1.07	280	300	4SPC

UNIT SIZE L					
	Nominal Output Speed	Pulley Ratio	Pulley Pitch diameters		Number of belts
			Motor	Gearbox	
20:1	10	7.14	140	1000	5SPB
	12	6.25	160	1000	4SPB
	14	5.26	190	1000	4SPB
	16	4.46	224	1000	3SPB
	18	4.00	200	800	4SPB
	20	3.77	212	800	4SPB
	22	3.32	190	630	5SPB
	24	3.02	265	800	3SPC
	26	2.81	224	630	6SPA
	28	2.64	212	560	5SPB
	30	2.50	224	560	5SPB
	32	2.25	355	800	3SPB
	34	2.13	375	800	3SPC
	38	1.91	236	450	5SPC
	40	1.87	300	560	4SPC
	42	1.77	300	530	4SPC
	46	1.60	250	400	6SPB
	50	1.48	425	630	3SPC
52	1.42	265	375	4QXPC	
54	1.35	315	425	4SPC	
13:1	58	1.87	300	560	5SPC
	62	1.77	300	530	5SPC
	65	1.67	300	500	5SPC
	70	1.58	400	630	5SPB
	74	1.48	425	630	3QXPC
	78	1.40	450	630	5SPB
	80	1.35	315	425	5SPC
	85	1.27	315	400	6SPB
	90	1.20	250	300	6SPC
	95	1.13	375	425	3SPC
100	1.07	280	300	5SPC	

UNIT SIZE M					
	Nominal Output Speed	Pulley Ratio	Pulley Pitch diameters		Number of belts
			Motor	Gearbox	
20:1	10	7.14	140	1000	6QXPB
	12	6.25	200	1250	5SPC
	14	5.30	236	1250	4SPC
	16	4.72	212	1000	6SPB
	18	4.24	236	1000	6SPB
	20	3.77	265	1000	4SPC
	22	3.39	236	800	6SPC
	24	3.17	315	1000	5SPB
	26	2.86	280	800	6SPB
	28	2.54	315	800	6SPB
	30	2.52	250	630	6SPC
	32	2.35	425	1000	3SPC
	34	2.25	280	630	4QXPC
	38	2.00	315	630	5SPC
	40	1.88	335	630	5SPC
	42	1.78	450	800	5SPB
	46	1.60	500	800	5SPB
	50	1.49	335	500	6SPC
52	1.42	335	475	6SPC	
13:1	54	2.11	475	1000	4SPC
	58	1.91	250	475	8QXPC
	62	1.79	265	475	8QXPC
	65	1.68	475	800	5SPC
	70	1.60	500	800	5SPC
	74	1.51	530	800	4QXPC
	78	1.42	335	475	8SPC
	80	1.40	400	560	8SPB
	85	1.27	355	450	8SPB
	90	1.24	450	560	4SPC
95	1.18	475	560	4SPC	
100	1.12	500	560	5SPB	

FOR INSTALLATION AND OPERATION OF BELT DRIVES SEE PAGE 74 OF THIS CATALOGUE

GEARBOX INSTALLATION

Satisfactory performance depends on proper installation, lubrication and maintenance. Therefore it is important that the instructions in the Installation and Maintenance leaflet, supplied with each gearbox, are followed carefully. Some of the important aspects of belt and torque-arm installation are listed below.

1. Install pulley on gearbox input shaft as close to the reducer as possible. See fig. 1. Failure to do this will cause excess loads in the input shaft bearings and could cause their premature failure.
2. Install motor and wedge belt drive with the belt pull at approximately 90° to the centre line between driven and input shafts. See fig. 2. This will permit tensioning of the wedge belt drive with the torque-arm which should preferably be in tension. If output hub runs anti-clockwise the torque arm should be positioned to the right. See fig. 3.
3. Install torque-arm fulcrum on a rigid support so that the torque-arm will be at approximately right angles to the centre line through the driven shaft and the torque arm case bolt. See fig. 4. Make sure there is sufficient take up in the turn-buckle for belt tension adjustment.

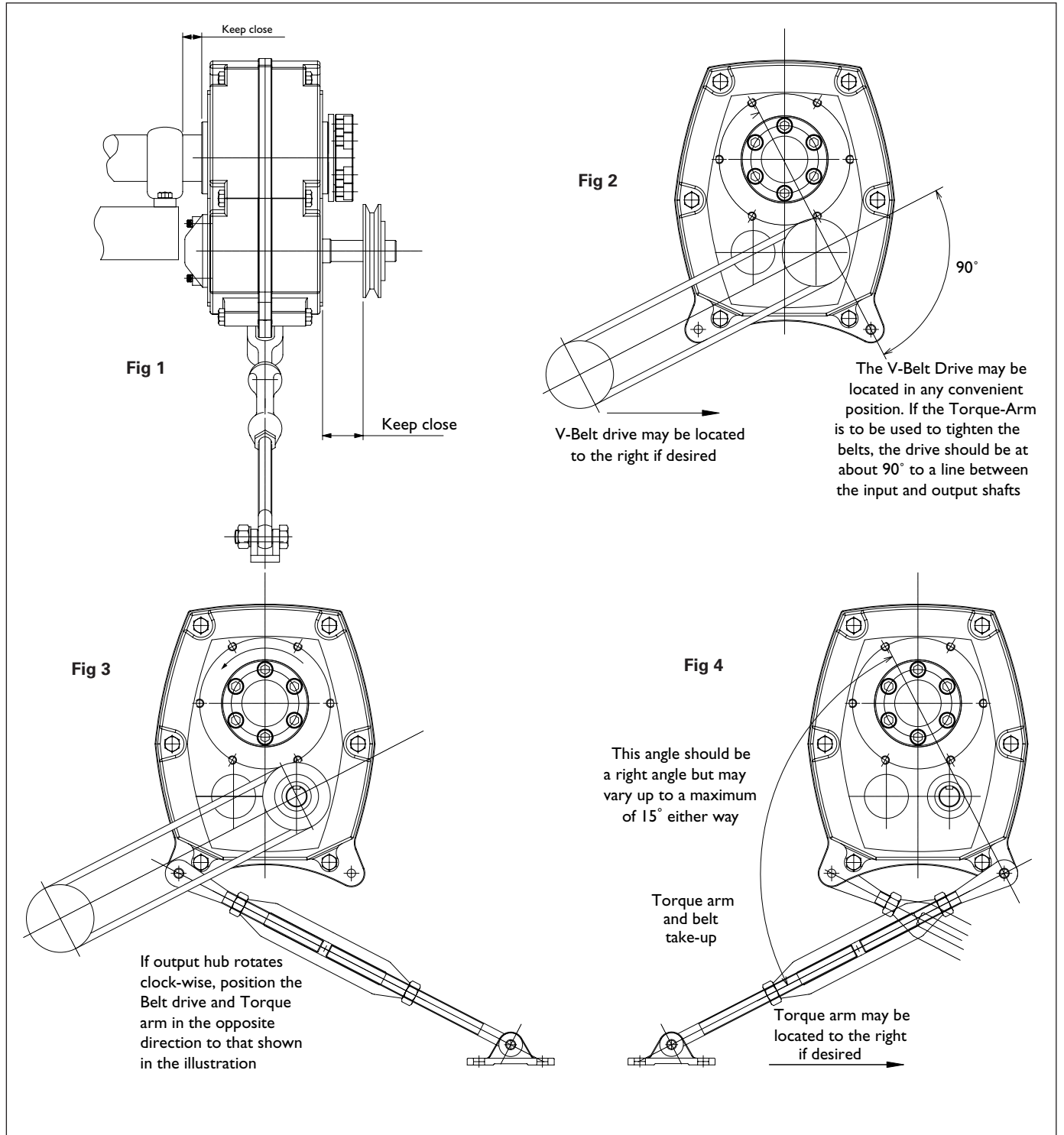

FOR INSTALLATION AND OPERATION OF BELT DRIVES SEE PAGE 74 OF THIS CATALOGUE

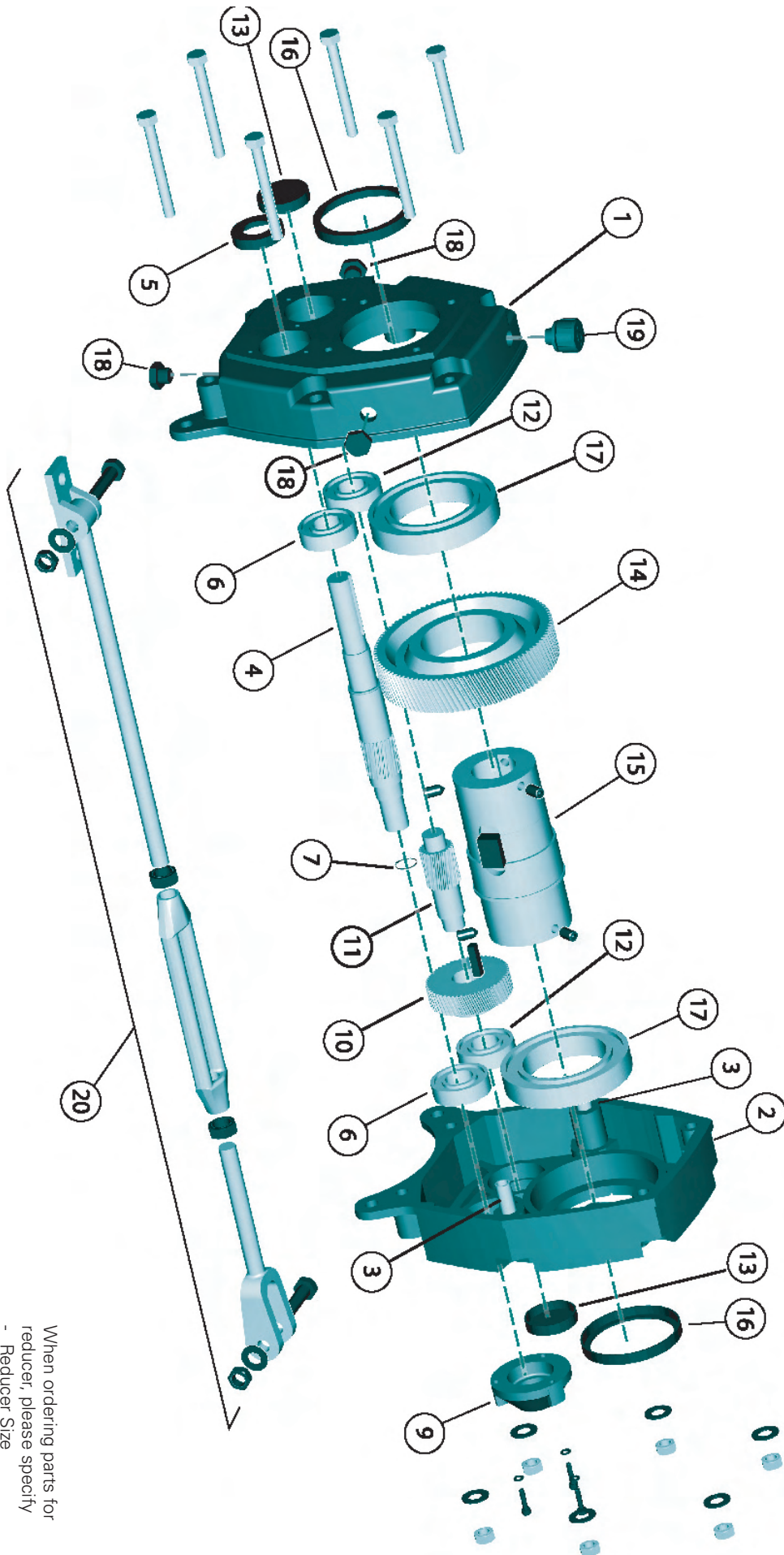

When ordering parts for reducer, please specify

- Reducer Size
- Reducer Serial No.
- Part Name
- Code number
- Quantity required

REPLACEMENT PARTS CODE LIST

Part No.	Description	No. Req'd	Unit Size									
			B	C	D	E	F	G	H	J	S	T
1	Case IPS	1	116B6001	116C6001	116D6001	116E6001	116F6001	116G6001	116H6001	116J6001	116S6001	116T6001
2	Case BSS	1	116B6002	116C6002	116D6002	116E6002	116F6002	116G6002	116H6002	116J6002	116S6002	116T6002
3	Hollow dowel	2	016A7004	016A7004	016C7004	016C7004	016E7004	016F7004	016F7004	016H7004	016H7004	016K7004
4	Input shaft 5:1	1	116B6005	116C6005	116D6005	116E6005	116F6005	116G6005	116H6005	116J6005	116S6005	116T6005
	Input shaft 13:1		116B6013	116C6013	116D6013	116E6013	116F6013	116G6013	116H6013	116J6013	116S6013	116T6013
	Input shaft 20:1		116B6020	116C6020	116D6020	116E6020	116F6020	116G6020	116H6020	116J6020	116S6020	116T6020
	Input shaft 25:1		116B6025	116C6025	116D6025	116E6025	116F6025	116G6025	116H6025	116J6025	116S6025	116T6025
5	Input shaft oilseal	1	G946040	G946030	G946031	G946032	G946033	G946034	G946035	G946036	G946037	G946038
6	Input shaft bearing	2	G941000	G941801	G941802	G941803	G941804	G941805	G941806	G941807	G941808	G941809
7	Input shaft retaining ring (20:1)	1	116X4180	116X4180	116X4181	116X4196	-	-	116X4184	116X4185	116X4186	-
	Input shaft retaining ring (25:1)	1	-	116X4180	-	-	116X4196	116X4182	116H6004	116J6004	116S6004	116X4188
9	Backstop cover	1	116B6600	116C6600	116D6600	116E6600	116F6600	116G6600	116H6600	116J6600	116S6600	116T6600
10	1st. Reduction 13:1	1	116B6113	116C6113	116D6113	116E6113	116F6113	116G6113	116H6113	116J6113	116S6113	116T6113
	1st. Reduction Gear 20:1	1	116B6120	116C6120	116D6120	116E6120	116F6120	116G6120	116H6120	116J6120	116S6120	116T6120
	1st. Reduction Gear 25:1	1	116B6125	116C6125	116D6125	116E6125	116F6125	116G6125	116H6125	116J6125	116S6125	116T6125
11	Intermediate pinion	1	116B6205	116C6205	116D6205	116E6205	116F6205	116G6205	116H6205	116J6205	116S6205	116T6205
12	Intermediate bearing	2	G941000	G941801	G941802	G941803	G941804	G941805	G941806	G941807	G941808	G941809
13	Intermediate cover	2	016A7025	016B7025	016C7025	016D7025	016E7025	016F7025	116H6285	116J6285	016J7025	016T7025
14	2nd. Reduction gear	1	116B6305	116C6305	116D6305	116E6305	116F6305	116G6305	116H6305	116J6305	116S6305	116T6305
15	Output hub (Standard Bore)	1	116B6030	116C6040	116D6050	116E6055	116F6065	116G6075	116H6085	116J6100	116S7120	116T6125
	Output hub (Upper Alt Bore)		116B6040	116C6050	116D6055	116DE065	116F6075	116G6085	116H6100	116J7120	116S6125	116T6135
	Output hub (Lower Alt Bore)		-	116C6030	116D6040	116E6050	116F6055	116G6065	116H6075	116J6085	116S6100	116T7120
	Output hub (Taper Grip)		116B6000	116C6000	116D6000	116E6000	116F6000	116G6000	116H6000	116J6000	116S6000	116T6000
16	Output hub oilseal	2	G946041	G946023	G946024	G946025	G946026	G946016	G946027	G946028	G946029	G946315
17	Output hub Bearing	2	G941350	G941351	G941352	G941353	G941354	G941355	G941356	G941357	G941358	G941050
18	Pipe plug	3	016X2395	016X2395	016X2395	016X2395	016X2392	016X2392	016X2392	016X2392	016X2392	016X2392
19	Breather plug	1	016X6097	016X6097	016X6097	016X6097	016X6098	016X6098	016X6098	016X6098	016X6098	016X6098
20	Torque arm assembly	1	116C0101	116C0101	116E0101	116E0101	116G0101	116G0101	116T0101	116T0101	116T0101	116T0101



FIG. 1 MOUNTING POSITIONS

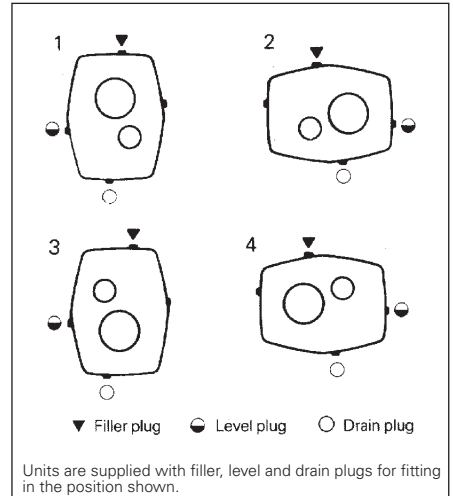

LUBRICATION – QUANTITIES & RECOMMENDED GRADES

Fenner Power Plus Shaft Mounted Speed Reducers are dispatched without oil. Before running they should be filled with an appropriate amount of lubricant as shown in the tables, dependent on the mounting position. Fill to level plug when reducer is not running. Drain, flush and refill as directed in the installation leaflet supplied with every gearbox, check oil level regularly.

Positions of filler, breather and drain plug for different mounting positions are shown in fig. 1. **CAUTION.** Too much oil will cause over-heating. Too little oil will cause gear and bearing failure.

Normal operating positions are shown in fig 1. Note that the reducer is supplied with four plugs. After the reducer has been mounted in its running position the plugs must be located as shown in fig 1 for the appropriate mounting position.

If the reducer is not within 20 degrees of one of the positions shown, the oil level plug cannot be safely used to check the oil level. This can be overcome by disconnecting the torque-arm and swinging the reducer around to one of the positions shown. Because of the many positions of fitting the reducer it may be necessary or desirable to make special adaptations using the plug holes in the reducer with standard pipe fittings standpipes or oil level gauges, consult your local Authorised Distributor.

OIL QUANTITIES (LITRES)

Unit Size	Approximate Capacity - Litres							
	5:1				13:1, 20:1 and 25:1			
	1	2	3	4	1	2	3	4
B	0.3	0.3	0.3	0.4	0.25	0.4	0.3	0.4
C	0.5	0.5	0.5	0.6	0.4	0.6	0.5	0.6
D	0.8	0.9	0.8	1.0	0.7	0.9	0.8	0.9
E	1.2	1.7	1.4	1.8	1.0	1.8	1.4	1.6
F	2.5	2.6	2.4	2.5	2.3	2.6	2.4	2.2
G	3.3	3.2	3.2	3.3	3.0	3.2	3.2	3.2
H	4.1	5.3	4.1	5.8	3.8	5.5	4.2	5.1
J	5.7	8.6	5.9	8.6	5.4	8.5	5.9	8.3
S	10.9	18.4	13.6	18.4	9.1	16.4	12.6	15.4
T	15.2	21.7	25.2	20.7	12.7	21.7	15.7	19.2
K					12.5	13.5	24.0	11.5
L					22.5	34.0	52.0	27.0
M					36.0	50.0	79.0	45.0

MINERAL OIL

	Ambient Temp °C	5:1 RATIO GEARBOX				13:1 AND 35:1 RATIO GEARBOXES						
		0-100 rev/min	101-200 rev/min	201-400 rev/min		0-20 rev/min	21-50 rev/min	51-120 rev/min		0 to 50 rev/min	51 to 80 rev/min	
		BCDEFGHJST	BCDEFGHJST	BCD	EFGHJST	BCDEFGHJST	BCDE	FGHJST	BCDE	FGHJST	KLM	
I.S.O.	-10 to +5	100	100	100	68	150	150	150	100	100	100	100
Viscosity Grade	6 to 25	460	320	320	220	680	680	460	460	320	320	220
	26 to 40	800	680	680	460	800	800	800	680	460	460	320

MANUFACTURERS AND TYPES

B.P ENERGOL GR-XP	CASTROL ALPHA ZN OR SP	MOBIL MOBILGEAR & SHC	SHELL OMALA	TEXACO MEROPA
-------------------------	------------------------------	-----------------------------	----------------	------------------

NOTE: Do not use E.P. mineral oils other than those recommended when using a backstop.