

# Stainlesssteel

# Gears

## Worm gearboxes and Coaxial gearboxes

Riduttori a vite senza fine e coassiali

Cat.: CT-SSM-I-HM010

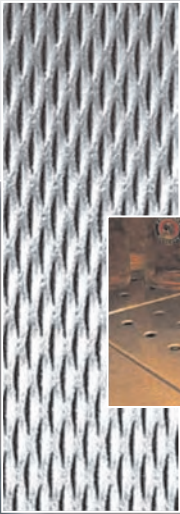

Made in Italy



### Worm gearboxes



### Coaxial gearboxes



*Patented*

### Stainless steel motors



# HYDRO • MEC



## Full Stainless steel - Worm gearboxes



**Full stainless steel Wormgear boxes.**  
Vite senza fine completamente in acciaio inox.

**See technical data table.**  
*Vedi tabelle dati tecnici.*

**Paragraph 8**

## Full Stainless steel - Coaxial gearboxes



**Full stainless steel Coaxial gearboxes.**  
Riduttori coassiali completamente in acciaio inox.

**See technical data table.**  
*Vedi tabelle dati tecnici.*

**Paragraph 9**

## Full Stainless steel electric motors



**Full stainless steel IEC motors.**  
Motori IEC completamente in acciaio inox.

**See technical data table.**  
*Vedi tabelle dati tecnici.*

**Pag. M-3**

# Stainless Steel Gears 130 ÷ 185

## STANDARD FEATURES



Special housing designed to keep adequate lubrication with low Oil q.ty to avoid internal pressures.



Full Stainless Steel Housing.



Output seals (FPM-fkm) with external dust protection lips.



Stainless Steel Hollow shaft.

O-rings on all closing covers.



Life lubricated fully synthetic oil

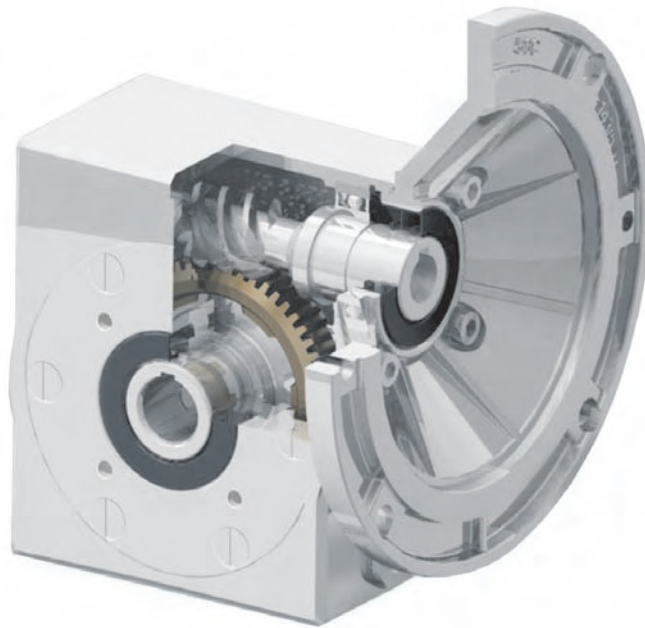

Optional interchangeable right or left hand output shafts available.

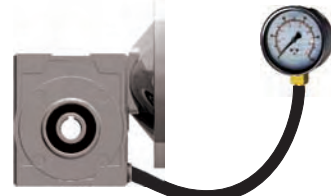

100 % Factory pressure leak test.

## OPTIONS

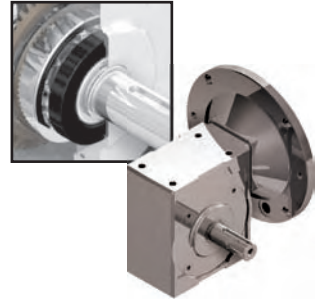

Protective seals cup to stand high pressure cleaning for hollow or extended shaft version.

Second Bearing

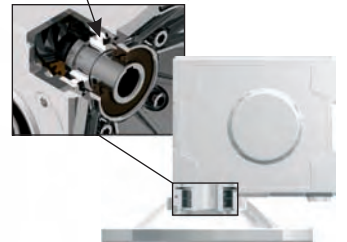

Standard second bearing on motor flange side and two oil seals with vertical motor position.

TORQUE ARM



On page / A pagina / Auf Seite / En la página



Types / Tipi /  
Arten / Tipos →

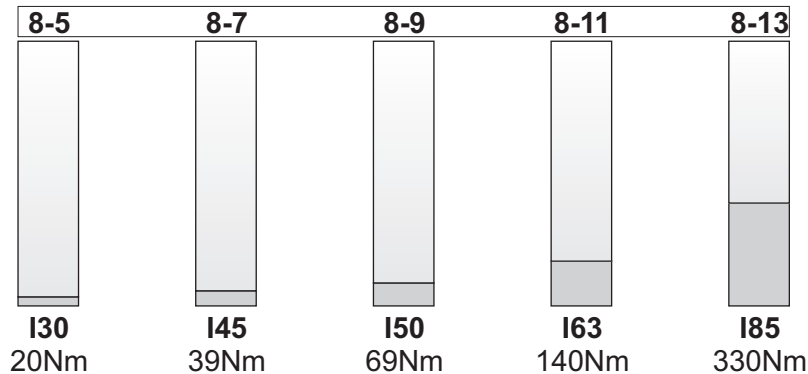

On page / A pagina / Auf Seite / En la página



Types / Tipi /  
Arten / Tipos →

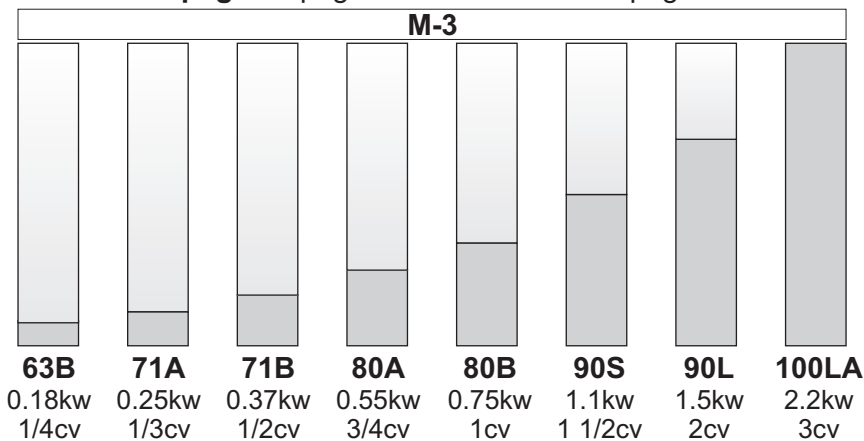

For : / Per : / Für : / Para :

**Selection guide - fs**  
Guida alla selezione

**Mounting pos. - Lubrication**  
Pos. di montaggio - lubrificazione

**2 - 6 poles selection**  
Selezione 2 - 6 poli

**Radial - axial loads**  
Carichi radiali e assiali

**Reversibility**  
Reversibilità

**Thermal limit**  
Limite termico

**Atex certification**  
Certificazione Atex

**Accessories**  
Accessori

**Download 3D drawings**  
Download disegni 3D

**Interchangeability**  
Intercambiabilità

**Installation and maintenance**  
Installazione, uso e manutenzione

**Spare parts list**  
Liste parti di ricambio

Use our web database to  
get detailed informations,  
always updated on  
each type/size.

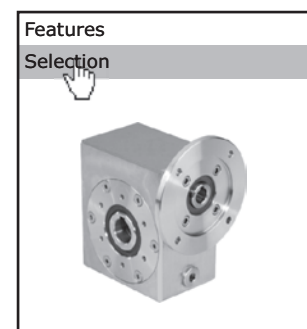

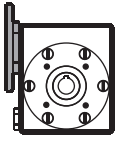
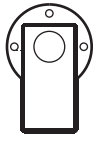
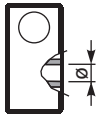
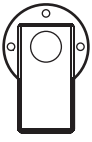
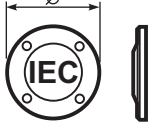
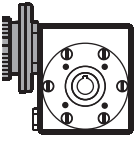
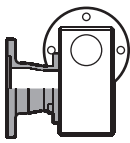
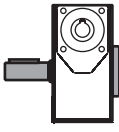
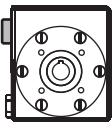
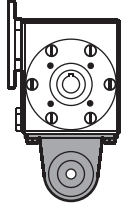
Type - Tipo Typ - Tipo	Size - Grandezza Grösse - Tamaño	Mounting - Montaggio Montage Tipo de montaje	Ratio - Rapporto Untersetzung Relación	Hub - Mozzo corona Hohlwelle Nucleo corona	Output shaft Albero lento Abtriebswelle Eje solida	Motor size Grandezza motore Motor Grösse Tamaño motor																								
<b>P</b>	<b>I45</b>	<b>UN</b>	<b>10</b>	<b>I</b>	<b>S</b>	<b>Q</b>																								
 <b>P</b>	<b>I30</b> <b>I45</b> <b>I50</b> <b>I63</b> <b>I85</b>	 <b>UN</b>	See technical data table  Vedi tabelle dati tecnici.  Ver tabla datos técnicos	 <b>I</b>	 <b>Ø</b>																									
 <b>M</b>		 <b>FL</b>		STANDARD I30 ⇨ ø14 I45 ⇨ ø18 I50 ⇨ ø25 I63 ⇨ ø25 I85 ⇨ ø35	 <b>S</b>																									
 <b>B</b>		 <b>BR</b> Full stainless steel Torque arm		<b>Z</b> INCH I45 ⇨ ø0.750" I50 ⇨ ø1.000" I63 ⇨ ø1.125" I85 ⇨ ø1.500"																										
						<table border="1"> <tr> <td><b>I30</b> 56B14 (ø80)</td> <td><b>P</b> 63B14 (ø90)</td> <td><b>W</b> 56C (ø6.5")</td> </tr> <tr> <td><b>I45</b> 63B14 (ø90)</td> <td><b>Q</b> 71B14 (ø105)</td> <td><b>W</b> 56C (ø6.5")</td> </tr> <tr> <td><b>I50</b> 63B14 (ø90)</td> <td><b>Q</b> 71B14 (ø105)</td> <td><b>R</b> 80B14 (ø120)</td> </tr> <tr> <td></td> <td><b>W</b> 56C (ø6.5")</td> <td></td> </tr> <tr> <td><b>I63</b> 71B14 (ø105)</td> <td><b>R</b> 80B14 (ø120)</td> <td><b>T</b> 90B14 (ø140)</td> </tr> <tr> <td></td> <td><b>W</b> 56C (ø6.5")</td> <td><b>X</b> 143/5TC (ø6.5")</td> </tr> <tr> <td><b>I85</b> 80B5 (ø200)</td> <td><b>E</b> 90B5 (ø200)</td> <td><b>U</b> 100-112B14 (ø160)</td> </tr> <tr> <td></td> <td><b>W</b> 56C (ø6.5")</td> <td><b>Y</b> 182/4TC (ø8.88")</td> </tr> </table>	<b>I30</b> 56B14 (ø80)	<b>P</b> 63B14 (ø90)	<b>W</b> 56C (ø6.5")	<b>I45</b> 63B14 (ø90)	<b>Q</b> 71B14 (ø105)	<b>W</b> 56C (ø6.5")	<b>I50</b> 63B14 (ø90)	<b>Q</b> 71B14 (ø105)	<b>R</b> 80B14 (ø120)		<b>W</b> 56C (ø6.5")		<b>I63</b> 71B14 (ø105)	<b>R</b> 80B14 (ø120)	<b>T</b> 90B14 (ø140)		<b>W</b> 56C (ø6.5")	<b>X</b> 143/5TC (ø6.5")	<b>I85</b> 80B5 (ø200)	<b>E</b> 90B5 (ø200)	<b>U</b> 100-112B14 (ø160)		<b>W</b> 56C (ø6.5")	<b>Y</b> 182/4TC (ø8.88")
<b>I30</b> 56B14 (ø80)	<b>P</b> 63B14 (ø90)	<b>W</b> 56C (ø6.5")																												
<b>I45</b> 63B14 (ø90)	<b>Q</b> 71B14 (ø105)	<b>W</b> 56C (ø6.5")																												
<b>I50</b> 63B14 (ø90)	<b>Q</b> 71B14 (ø105)	<b>R</b> 80B14 (ø120)																												
	<b>W</b> 56C (ø6.5")																													
<b>I63</b> 71B14 (ø105)	<b>R</b> 80B14 (ø120)	<b>T</b> 90B14 (ø140)																												
	<b>W</b> 56C (ø6.5")	<b>X</b> 143/5TC (ø6.5")																												
<b>I85</b> 80B5 (ø200)	<b>E</b> 90B5 (ø200)	<b>U</b> 100-112B14 (ø160)																												
	<b>W</b> 56C (ø6.5")	<b>Y</b> 182/4TC (ø8.88")																												

## On request

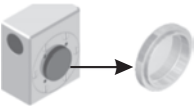
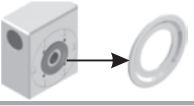
<b>A</b>	<b>Protective seals cup</b> CLOSE TYPE	
<b>B</b>	<b>Protective seals cup</b> OPEN TYPE	
<b>C</b>	<b>Food lube</b>	
<b>D</b>	<b>Nema input flanges</b>	

**M**  
without flange  
Senza flangia

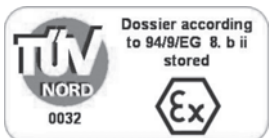

A richiesta possiamo fornire i nostri prodotti secondo le normative ATEX

On request we can deliver our products according to the ATEX

Auf Anfrage können wir unsere Produkte den Richtlinien ATEX entsprechend liefern

A pedido, se pueden enviar nuestros productos de acuerdo con las normas ATEX.



REQUIRED POWER / POTENZA RICHIESTA / ERFORDERLICHE LEISTUNG / POTENCIA NECESARIA

Lifting / sollevamento / hubantriebe / elevación

$$P \text{ [KW]} = \frac{M \text{ [Kg]} \cdot g \text{ [9.81]} \cdot v \text{ [m / s]}}{1000}$$

Rotation / rotazione / drehung / rotation

$$P \text{ [KW]} = \frac{M \text{ [Nm]} \cdot n \text{ [rpm]}}{9550}$$

Linear movement / traslazione / linearbewegung / translacion

$$P \text{ [KW]} = \frac{F \text{ [N]} \cdot v \text{ [m / s]}}{1000}$$

TORQUE / COPPIA / DREHMOMENT / PAR

$$M \text{ [Nm]} = \frac{9550 \cdot P \text{ [KW]}}{n \text{ [rpm]}}$$

$$M \text{ [lb in]} = \frac{63030 \cdot P \text{ [HP]}}{n \text{ [rpm]}}$$

RADIAL LOADS / CARICHI RADIALI / RADIALE - UND AXIALLASTEN / CARGA RADIAL Y AXIAL

- Radial load generated by external transmissions keyed onto input and/or output shafts.
- Forza radiale generata da organi di trasmissione calettati sugli alberi di ingresso e/o uscita.
- Belastungen der Antriebs- bzw. Abtriebswellen durch von aussen eingebrachte Radiallasten.
- Cargas radiales, generada por transmisiones externas, aplicadas sobre los ejes de entrada y/o salida

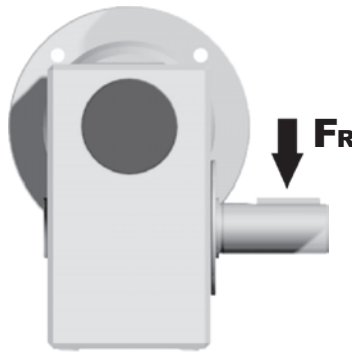

	$F_R \text{ [N]} = \frac{M \text{ [Nm]} \cdot 2000}{d \text{ [mm]}} \cdot f_k$	$F_R \text{ [N]} = \frac{M \text{ [lb in]} \cdot 8.9}{d \text{ [in]}} \cdot f_k$
<b>M</b>	Output torque / Momento torcente / Abtriebsdrehmoment / Par torsion	
<b>d</b>	Diam. of driving element / Diametro primitivo / Durchmesser der Abtriebseinheit / Diámetro primitivo	
<b>f<sub>k</sub></b>	Factor / Coefficiente di trasformazione / Faktor / Coefficiente de transmisión <b>1.15</b> Gearwheels / Ingranaggi / Zahnrad / Engranaje <b>1.25</b> Chain sprochets / Catena / Antriebskette / Cadena <b>1.75</b> Narrow v-belt pulley / Cinghia Trapezoidale / Keilriemen / Correa trapezoidal <b>2.50</b> Flat-belt pulley / Cinghia piatta / Flachzahnriem. / Correa plana	

- If your application requires higher radial loads, contact our technical office. Higher load may be possible.
- Nel caso la vostra applicazione richieda carichi radiali superiori consultare il nostro ufficio tecnico, valori maggiori possono essere accettati.
- Wenn Ihre Anwendung höhere Radialbelastungen erfordert, so wenden Sie sich bitte an unser technischen Büro.
- En el caso en que una aplicación exija una carga radial superior a la especificada en el catálogo, consultar a nuestra oficinas técnica.

How to select a gearbox / Come selezionare un riduttore  
Wie wählt man ein Getriebe / Cómo seleccionar un reductor

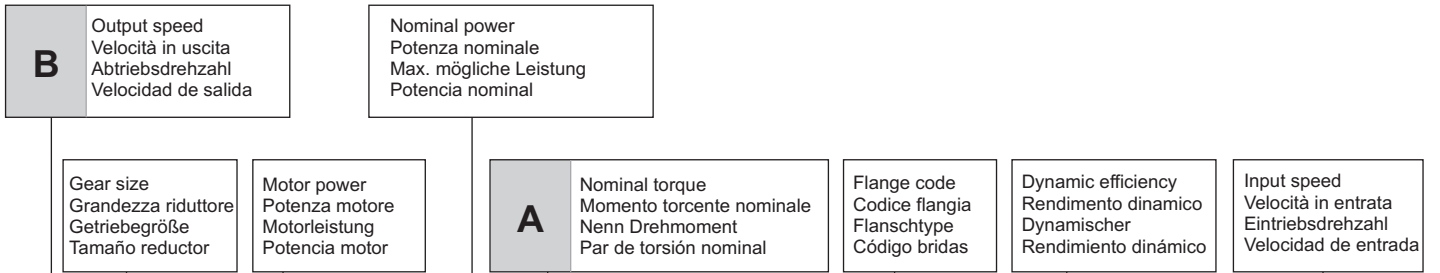

**145** Rightangle - Gear  
**39Nm** Rating - Stainlesssteel WORM GEARBOXES

QUICK SELECTION / Selezione veloce

Output Speed $n_2$ [min <sup>-1</sup> ]	Ratio $i$	Motor power $P_{1M}$ [kW]	Output torque $M_{2M}$ [Nm]	Service factor f.s.	Nominal power $P_{1R}$ [kW]	Nominal torque $M_{2R}$ [Nm]	Available B5 motor flanges		Available B14 motor flanges			Dynamic efficiency RD	Tooth Module Mn	Ratios code
							B	C	O	P	Q			
							63	71	56	63	71			
200	7	0.37	14	2.1	0.76	29	B		B-C	B-C		80	2.2	01
140	10	0.37	20	1.5	0.54	29	B		B-C	B-C		79	2.2	02
100	14	0.37	27	1.1	0.39	29	B		B-C	B-C		77	2.4	03

input speed (n<sub>1</sub>) = 1400 min<sup>-1</sup>



fs		Oper. hours per day Ore di funz. giorn.			
Type of load and starts per hour Tipo di carico e avviamenti per ora		<2 h	2 - 8 h	8 - 16 h	
Continuous or intermittent appl. with start / hour Applicazione cont. o interm. con n.ro operazioni/ora	≤ 10	Uniform / Uniforme	0.9	1	1.25
		Moderate / Moderato	1	1.25	1.5
		Heavy / Forte	1.25	1.5	1.75
Intermittent application with start / hour Applicazione intermittente con n.ro operazioni/ora	> 10	Uniform / Uniforme	1.25	1.5	1.75
		Moderate / Moderato	1.5	1.75	2
		Heavy / Forte	1.75	2	2.25

D	Motor flange available Flange disponibili Erhältliche Motorflansche Bridas disponibles
B)	Mounting with reduction ring Montaggio con boccola di riduzione Reduzierhülsen Montaje con casquillo de reducción
C)	Motor flangeholes position/terminal box position Posizione fori flangia/basetta motore Bohrungsposition am Motorflansch/-sockel Posición agujeros brida / base motor
B)	Available without reduction bushes Disponibile anche senza boccola Auch ohne Reduzierbuchse verfügbar Disponible tambien sin casquillo

<b>A</b>	Select required torque (according to service factor)	Seleziona la coppia desiderata (comprensiva del fattore di servizio)	Max. Drehmoment in Bezug zum Betriebsfaktor	Seleccionar el par deseado (incluyendo el factor de servicio)
<b>B</b>	Select output speed	Seleziona la velocità in uscita	Ausgewählte Abtriebsdrehzahl	Seleccionar la velocidad de salida
<b>C</b>	On the same line of selected geared motor, you can find the gear ratio	Sulla riga corrispondente alla motorizzazione prescelta si può rilevare il rapporto di riduzione	Auf der gleichen Linie wie die ausgewählte Motorleistung steht auch die Getriebeuntersetzung	En la línea correspondiente al motor preseleccionado es posible encontrar la relación de reducción
<b>D</b>	Select motor flange available (if requested)	Scegli la flangia disponibile (se richiesta)	Erhältliche Motorflansche (auf Anfrage)	Seleccionar la brida disponible (sobre pedido)



#### QUICK SELECTION / Selezione veloce

input speed ( $n_1$ ) = 1400 min<sup>-1</sup>

Output Speed $n_2$ [min <sup>-1</sup> ]	Ratio $i$	Motor power $P_{1M}$ [kW]	Output torque $M_{2M}$ [Nm]	Service factor f.s.	Nominal power $P_{1R}$ [kW]	Nominal torque $M_{2R}$ [Nm]	B5 motor flanges not available		Available B14 motor flanges		Dynamic efficiency <b>RD</b>	Tooth Module  Mn[mm]	 Ratios code
							-	-	O	P			
280	<b>5</b>	0.18	5	3.2	<b>0.57</b>	<b>16</b>	-	-	B-C	63	82	1.26	09
200	<b>7</b>	0.18	7	2.3	<b>0.42</b>	<b>16</b>	-	-	B-C	63	80	1.44	01
140	<b>10</b>	0.18	10	1.7	<b>0.30</b>	<b>16</b>	-	-	B-C	63	78	1.44	02
93	<b>15</b>	0.18	13	1.3	<b>0.24</b>	<b>18</b>	-	-	B-C	63	73	1.44	03
70	<b>20</b>	0.18	17	1.0	<b>0.19</b>	<b>18</b>	-	-	B-C	63	70	1.09	04
47	<b>30</b>	0.12	15	1.3	<b>0.16</b>	<b>20</b>	-	-	B-C	63	62	1.44	05
35	<b>40</b>	0.12	19	1.0	<b>0.12</b>	<b>19</b>	-	-	B-C	63	57	1.09	06
23	<b>61</b>	0.09	19	1.0	<b>0.09</b>	<b>19</b>	-	-	B-C	63	50	0.72	07
17.5	<b>80</b>	0.09	16	1.0	<b>0.06</b>	<b>15</b>	-	-	B-C	63	48	0.56	08

**A** Motor Flanges Available  
Flange Motore Disponibili

**B** Supplied with Reduction Bushing  
Fornito con Bussola di Riduzione

**B** Available on Request without reduction bushing  
Disponibile a Richiesta senza Bussola di Riduzione

**C** Motor Flange Holes Position  
Posizione Fori Flangia Motore

**EN** Unit I30 is supplied with synthetic oil, providing "long life" lubrication. For mounting position V5-V6 please contact us. See table 1 for lubrication and recommended quantity. In table 2 please see possible radial loads and axial loads on the gearbox. For complete documentation please visit our web site.

**I** Il riduttore tipo I30 viene fornito lubrificato a vita con olio sintetico. Per posizioni V5-V6 contattare il ns. servizio tecnico. Vedi tab.1 per oli e quantità consigliati. In tab.2 sono presenti i carichi radiali e assiali applicabili al riduttore. Per la documentazione completa consulta il nostro sito.

**D** Für die Lebensdauerschmierung ist das Getriebe der Größe I30 mit synthetischem Öl befüllt. Bei Einbaulage V5 oder V6 bitten wir um Rücksprache. In Tabelle 1 ist die Schmiermenge und das empfohlene Schmiermittel angegeben. In Tabelle 2 sind die zulässigen Radial- und Axialbelastungen des Getriebes aufgeführt. Die komplette Dokumentation, Wartungs- und Inbetriebnahmeanleitungen finden Sie unter.

**E** El reductor tamaño I30 se suministra, lubricado de por vida con aceite sintético. Para las posiciones V5 y V6 contactar con nuestro servicio técnico. Ver tabla 1, para cantidades y aceites recomendados. En la tabla 2, se encuentran las cargas radiales y axiales admitidas por el reductor. Para documentación completa, consultar nuestra Web.

#### LUBRICATION I30 Oil Quantity 0.10 Lt.

AGIP	KLUBER	SHELL	MOBIL
Telium VSF 320	Syntheso D220 EP	Tivela Oil WB	Glygoyl 30 SHC 630

tab. 1

#### RADIAL AND AXIAL LOADS

##### Output shaft

Albero di uscita

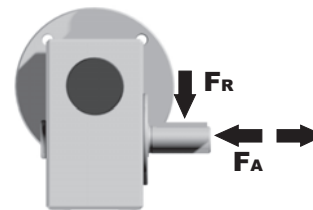

$n_2$ [min <sup>-1</sup> ]	FA [N]	FR [N]
<b>200</b>	120	600
<b>150</b>	140	700
<b>100</b>	160	800
<b>75</b>	180	900
<b>50</b>	200	1000
<b>25</b>	250	1250
<b>15</b>	280	1400

tab. 2

**SELECT THIS TYPE AND THIS SPECIFIC SIZE ON THE WEB PAGES TO GET COMPLETE TECHNICAL DATA.**  
Selezionare tipo e grandezza specifica nel sito web per la documentazione completa.

Wormbox weight peso riduttore **2.5 kg**

PI30**UN**... Basic wormbox  
Riduttore base

M. flanges	Kit code	øF	A
<b>56B14</b>	KI30.4.046	80	61.5
<b>63B14</b>	KI30.4.045	90	62.5

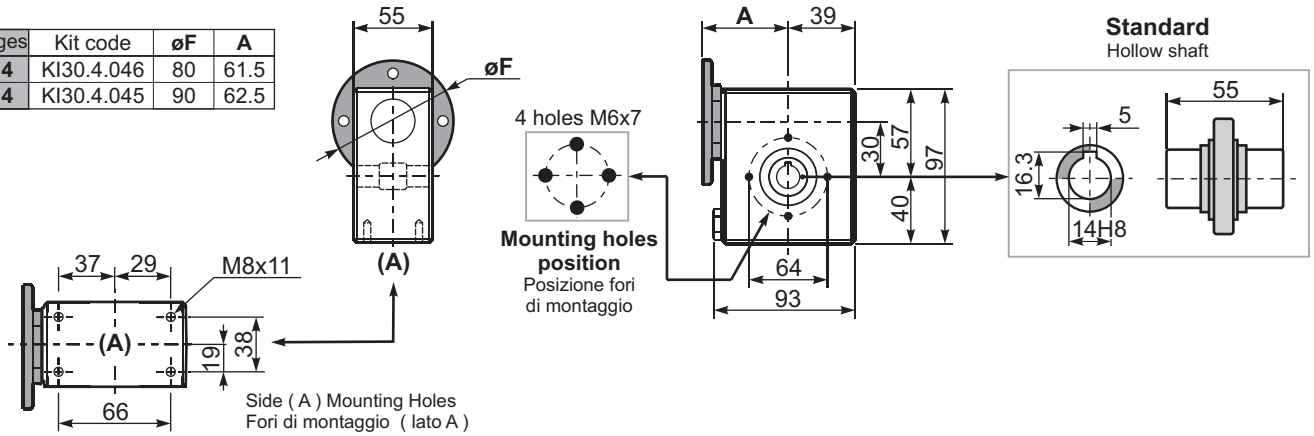

PI30**UN**... Modular base  
Base modulare

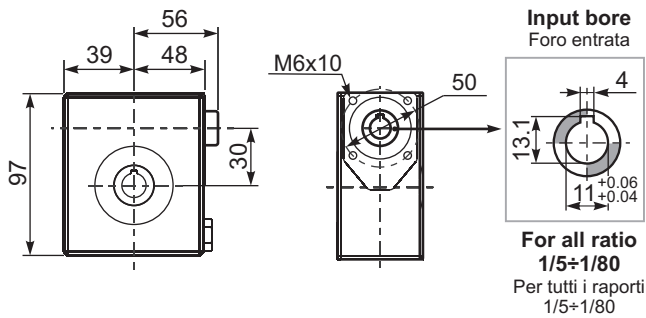

PI30**FL**... Output flange  
Flangia uscita

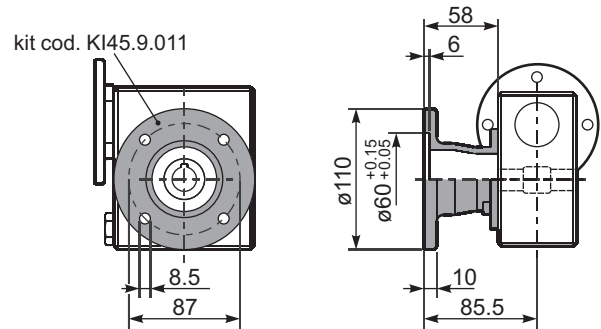

PI30**BR**... Reaction arm  
Braccio di reazione

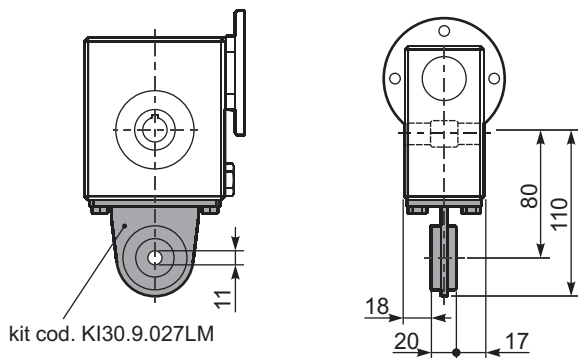

PI30.....**S**... Single Shaft  
Albero lento semplice

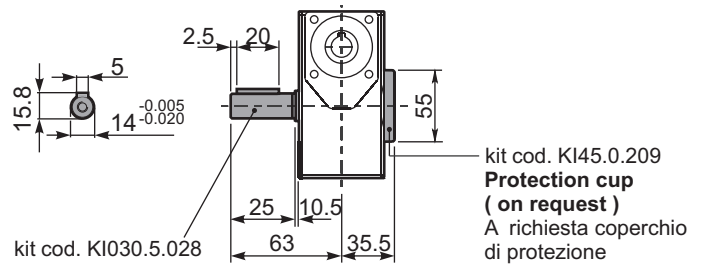



QUICK SELECTION / Selezione veloce							input speed (n <sub>1</sub> ) = 1400 min <sup>-1</sup>						
Output Speed n <sub>2</sub> [min <sup>-1</sup> ]	Ratio i	Motor power P <sub>1M</sub> [kW]	Output torque M <sub>2M</sub> [Nm]	Service factor f.s.	Nominal power P <sub>1R</sub> [kW]	Nominal torque M <sub>2R</sub> [Nm]	B5 motor flanges not available		Available B14 motor flanges		Dynamic efficiency RD	Tooth Module Mn[mm]	Ratios code
							-	-	P	Q			
200	7	0.37	14	2.1	0.76	29	-	-	B-C	71	80	2.2	01
140	10	0.37	20	1.5	0.54	29	-	-	B-C	71	79	2.2	02
100	14	0.37	27	1.1	0.39	29	-	-	B-C	71	77	2.4	03
67	21	0.37	36	1.1	0.41	39	-	-	B-C	71	67	1.6	04
50	28	0.25	31	1.3	0.31	39	-	-	B-C	71	65	2.5	05
38	37	0.25	40	1.0	0.25	39	-	-	B-C	71	63	1.8	06
30	46	0.25	46	0.8	0.21	39	-	-	B-C	71	59	1.5	07
23	60	0.18	41	0.9	0.17	39	-	-	B-C	71	56	1.2	08
20	70	0.12	31	0.9	0.11	29	-	-	B-C	71	54	1.0	09
13.7	102	0.09*	28	<0.8	0.08	28	-	-	B-C	71	49	0.72	10

Motor Flanges Available Flange Motore Disponibili    
 B) Supplied with Reduction Bushing Fornito con Bussola di Riduzione    
 B) Available on Request without reduction bushing Disponibile a Richiesta senza Bussola di Riduzione    
 C) Motor Flange Holes Position Posizione Fori Flangia Motore

\* Power higher than the maximum one which can be supported by the gearbox. Select according to the torque M<sub>2R</sub>  
 Potenza superiore a quella massima sopportabile dal riduttore. Selezionare in base al momento torcente M<sub>2R</sub>

**EN** Unit I45 is supplied with synthetic oil, providing "long life" lubrication. For mounting position V5-V6 please contact us. See table 1 for lubrication and recommended quantity. In table 2 please see possible radial loads and axial loads on the gearbox. For complete documentation please visit our web site.

**I** Il riduttore tipo I45 viene fornito lubrificato a vita con olio sintetico. Per posizioni V5-V6 contattare il ns. servizio tecnico. Vedi tab.1 per oli e quantità consigliati. In tab.2 sono presenti i carichi radiali e assiali applicabili al riduttore. Per la documentazione completa consulta il nostro sito.

**D** Für die Lebensdauerschmierung ist das Getriebe der Größe I45 mit synthetischem Öl befüllt. Bei Einbaulage V5 oder V6 bitten wir um Rücksprache. In Tabelle 1 ist die Schmiermenge und das empfohlene Schmiermittel angegeben. In Tabelle 2 sind die zulässigen Radial - und Axialbelastungen des Getriebes aufgeführt. Die komplette Dokumentation, Wartungs - und Inbetriebnahmeanleitungen finden Sie unter.

**E** El reductor tamaño I45 se suministra, lubricado de por vida con aceite sintético. Para las posiciones V5 y V6 contactar con nuestro servicio técnico. Ver tabla 1, para cantidades y aceites recomendados. En la tabla 2, se encuentran las cargas radiales y axiales admitidas por el reductor. Para documentación completa, consultar nuestra Web.

### ■ LUBRICATION I45 Oil Quantity 0.24 Lt.

AGIP	KLUBER	SHELL	MOBIL
Telium VSF 320	Syntheso D220 EP	Tivela Oil WB	Glygoyl 30 SHC 630

tab. 1

### ■ RADIAL AND AXIAL LOADS

Output shaft  
Albero di uscita

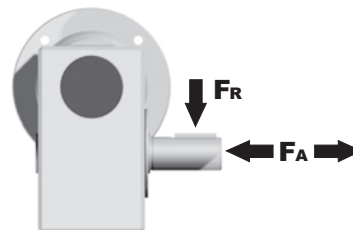

n <sub>2</sub> [min <sup>-1</sup> ]	FA [N]	FR [N]
200	180	900
150	200	1000
100	220	1100
75	240	1200
50	260	1400
25	300	1800
15	400	2000

tab. 2

■ **SELECT THIS TYPE AND THIS SPECIFIC SIZE ON THE WEB PAGES TO GET COMPLETE TECHNICAL DATA.**  
 Selezionare tipo e gandezza specifica nel sito web per la documentazione completa.

Wormbox weight  
peso riduttore **5.0 kg**

PI45**UN**... Basic wormbox  
Riduttore base

M. flanges	Kit code	øF	A
63B14	KI50.4.047	90	73.5
71B14	KI50.4.045	105	71

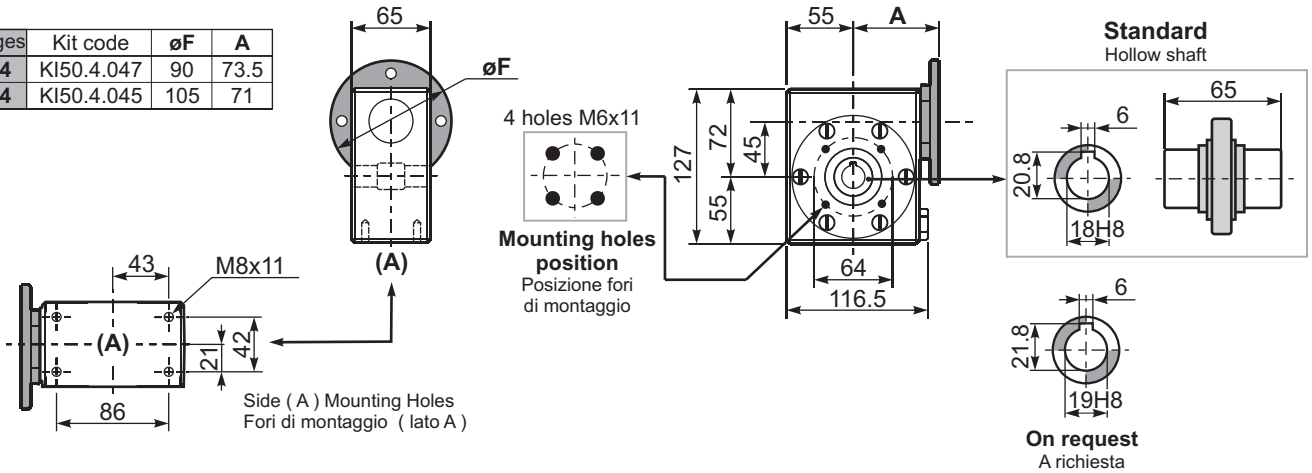

BI45UN... Modular base  
Base modulare

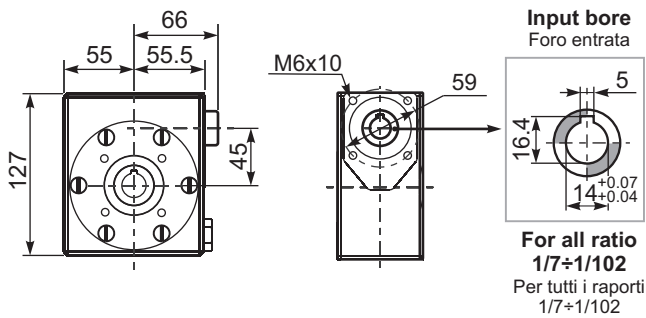

PI45FL... Output flange  
Flangia uscita

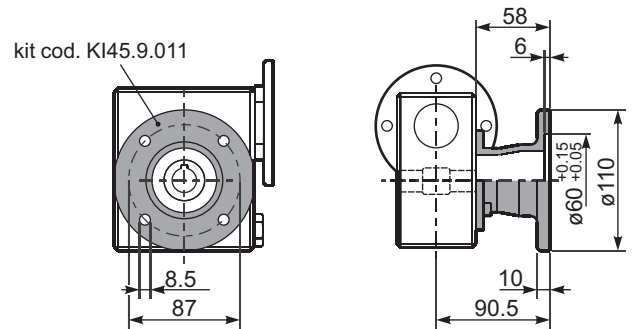

PI45BR... Reaction arm  
Braccio di reazione

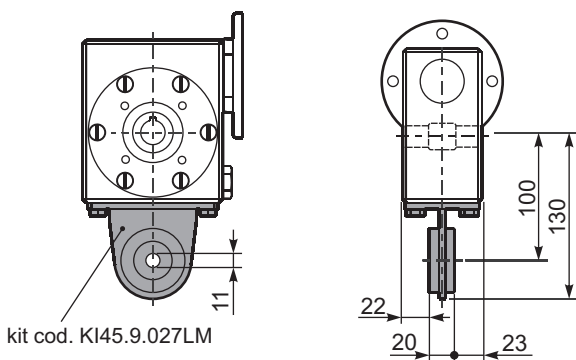

PI45....S... Single Shaft  
Albero lento semplice

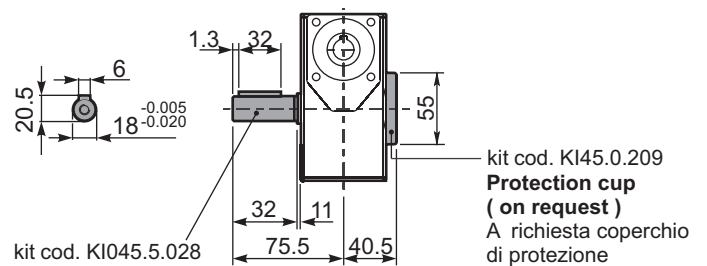



▪ **QUICK SELECTION** / Selezione veloce

input speed ( $n_1$ ) = 1400 min<sup>-1</sup>

Output Speed $n_2$ [min <sup>-1</sup> ]	Ratio i	Motor power $P_{1M}$ [kW]	Output torque $M_{2M}$ [Nm]	Service factor f.s.	Nominal power $P_{1R}$ [kW]	Nominal torque $M_{2R}$ [Nm]	B5 motor flanges not available		Available B14 motor flanges			Dynamic efficiency RD	Tooth Module Mn[mm]	Ratios code
							-	-	P	Q	R			
200	7	0.75	29	1.8	1.4	54			B-C	B		82	2.5	01
140	10	0.75	41	1.4	1.1	59			B-C	B		80	2.4	02
100	14	0.75	57	1.1	0.86	65			B-C	B		79	2.6	03
78	18	0.55	51	1.2	0.64	59			B-C	B		75	2.0	04
54	26	0.55	67	0.9	0.51	63			B-C	B		69	2.7	05
39	36	0.37	63	1.1	0.41	69			B-C			69	2.1	06
33	43	0.37	72	0.9	0.34	65			B-C			66	1.8	07
23	60	0.25	59	1.0	0.25	59			B-C			58	1.3	08
21	68	0.25	66	0.8	0.21	55			B-C			57	1.2	09
17.5	80	0.18	53	1.0	0.18	54			B-C			54	1.0	10
14	100	0.12	41	1.2	0.14	49			B-C			50	0.8	11

Motor Flanges Available  
Flange Motore Disponibili

B) Supplied with Reduction Bushing  
Fornito con Bussola di Riduzione

B) Available on Request without reduction bushing  
Disponibile a Richiesta senza Bussola di Riduzione

C) Motor Flange Holes Position  
Posizione Fori Flangia Motore

**EN** Unit I50 is supplied with synthetic oil, providing "long life" lubrication. For mounting position V5-V6 please contact us. See table 1 for lubrication and recommended quantity. In table 2 please see possible radial loads and axial loads on the gearbox.  
For complete documentation please visit our web site.

▪ **LUBRICATION I50 Oil Quantity 0.38 Lt**

AGIP	KLUBER	SHELL	MOBIL
Telium VSF 320	Syntheso D220 EP	Tivela Oil WB	Glygoyl 30 SHC 630

tab. 1

**I** Il riduttore tipo I50 viene fornito lubrificato a vita con olio sintetico. Per posizioni V5-V6 contattare il ns. servizio tecnico. Vedi tab.1 per oli e quantità consigliati. In tab.2 sono presenti i carichi radiali e assiali applicabili al riduttore.  
Per la documentazione completa consulta il nostro sito.

▪ **RADIAL AND AXIAL LOADS**

Output shaft  
Albero di uscita

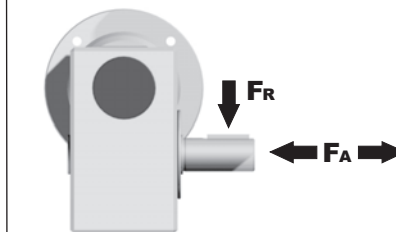

$n_2$ [min <sup>-1</sup> ]	FA [N]	FR [N]
200	240	1200
150	280	1400
100	300	1500
75	340	1700
50	380	1900
25	480	2500
15	560	2800

tab. 2

**D** Für die Lebensdauerschmierung ist das Getriebe der Größe I50 mit synthetischem Öl befüllt. Bei Einbaulage V5 oder V6 bitten wir um Rücksprache. In Tabelle 1 ist die Schmiermenge und das empfohlene Schmiermittel angegeben. In Tabelle 2 sind die zulässigen Radial- und Axialbelastungen des Getriebes aufgeführt. Die komplette Dokumentation, Wartungs- und Inbetriebnahmeanleitungen finden Sie unter.

**E** El reductor tamaño I50 se suministra, lubricado de por vida con aceite sintético. Para las posiciones V5 y V6 contactar con nuestro servicio técnico. Ver tabla 1, para cantidades y aceites recomendados. En la tabla 2, se encuentran las cargas radiales y axiales admitidas por el reductor.  
Para documentación completa, consultar nuestra Web.

▪ **SELECT THIS TYPE AND THIS SPECIFIC SIZE ON THE WEB PAGES TO GET COMPLETE TECHNICAL DATA.**  
Selezionare tipo e gandezza specifica nel sito web per la documentazione completa.

Wormbox weight  
peso riduttore **7.3 kg**

PI50**UN**... Basic wormbox  
Riduttore base

M. flanges	Kit code	øF	A
<b>63B14</b>	KI50.4.047	90	78
<b>71B14</b>	KI50.4.045	105	78
<b>80B14</b>	KI50.4.046	120	76

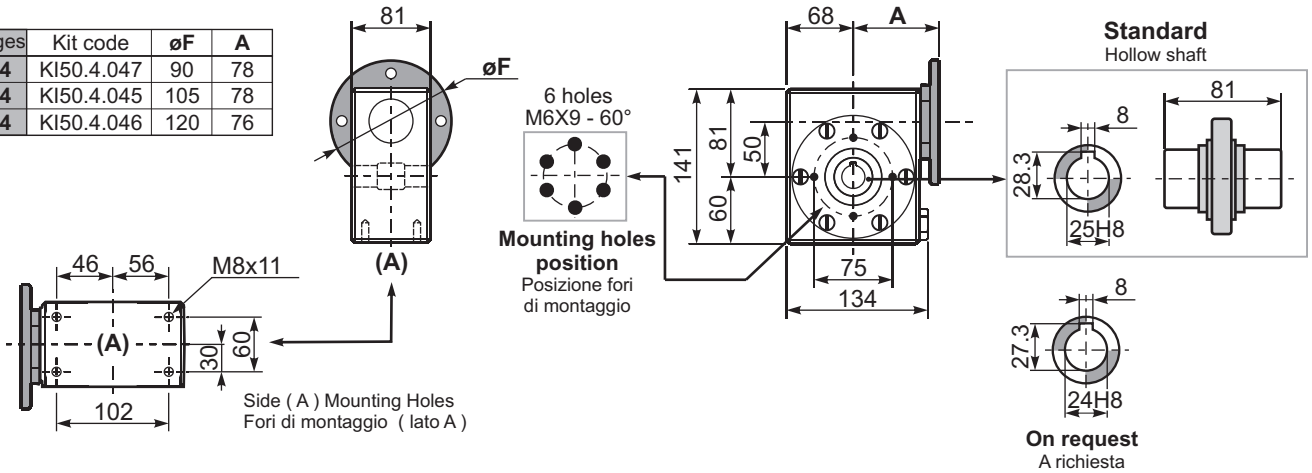

PI50**UN**... Modular base  
Base modulare

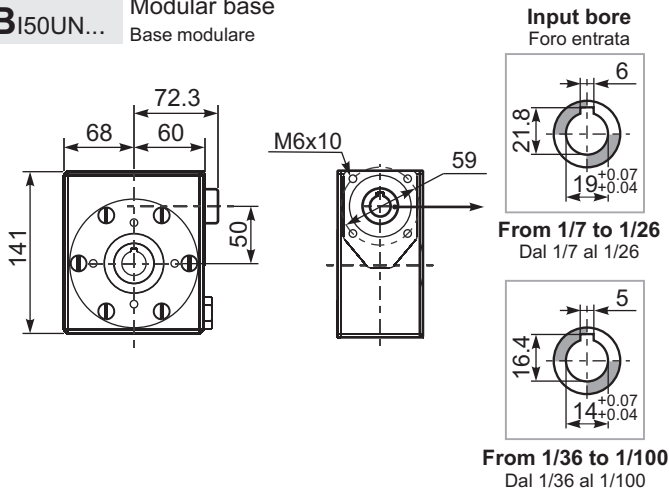

PI50**FL**... Output flange  
Flangia uscita

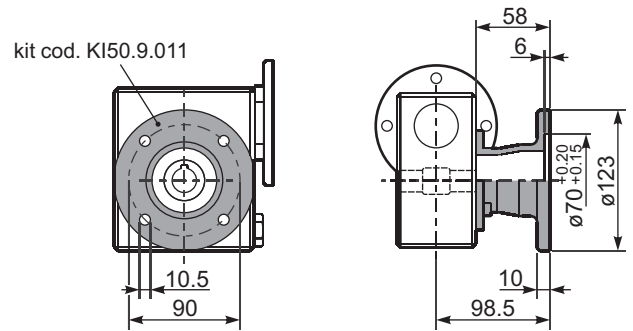

PI50**BR**... Reaction arm  
Braccio di reazione

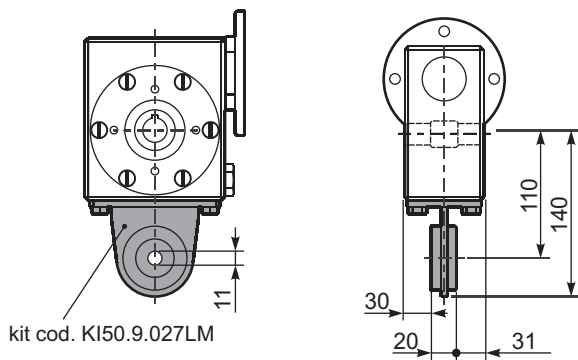

PI50.....**S**... Single Shaft  
Albero lento semplice

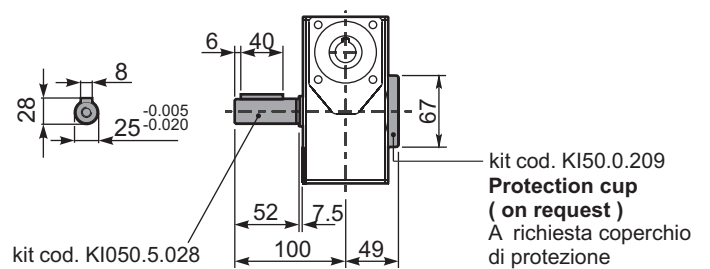



▪ **QUICK SELECTION** / Selezione veloce

input speed ( $n_1$ ) = 1400 min<sup>-1</sup>

Output Speed $n_2$ [min <sup>-1</sup> ]	Ratio $i$	Motor power $P_{1M}$ [kW]	Output torque $M_{2M}$ [Nm]	Service factor f.s.	Nominal power $P_{1R}$ [kW]	Nominal torque $M_{2R}$ [Nm]	B5 motor flanges not available		Available B14 motor flanges			Dynamic efficiency RD	Tooth Module Mn [mm]	Ratios code
							-	-	Q	R	T			
200	7	1.8	71	1.7	3.0	119			B-C	B-C		83	3.1	01
140	10	1.8	99	1.3	2.3	128			B-C	B-C		81	3.1	02
93	15	1.5	121	1.1	1.6	131			B-C	B-C		79	3.1	03
74	19	1.1	111	1.2	1.3	131			B-C	B-C		78	2.6	04
58	24	1.1	135	1.0	1.1	135			B-C	B-C		75	2.0	05
47	30	1.1	167	0.8	0.92	139			B-C	B-C		74	3.2	06
39	36	0.75	125	1.1	0.84	140			B-C	B-C		68	2.7	07
31	45	0.55	111	1.2	0.63	129			B-C	C		66	2.1	08
21	67	0.55	151	0.8	0.43	118			B-C	C		60	1.5	09
17.5	80	0.37	115	1.0	0.36	113			B-C	C		57	1.3	10
14.9	94	0.37	123	0.9	0.34	113			B-C	C		52	1.1	11

Motor Flanges Available  
Flange Motore Disponibili

B) Supplied with Reduction Bushing  
Fornito con Bussola di Riduzione

B) Available on Request without reduction bushing  
Disponibile a Richiesta senza Bussola di Riduzione

C) Motor Flange Holes Position  
Posizione Fori Flangia Motore

**EN** Unit I63 is supplied with synthetic oil, providing "long life" lubrication. For mounting position V5-V6 please contact us. See table 1 for lubrication and recommended quantity. In table 2 please see possible radial loads and axial loads on the gearbox. For complete documentation please visit our web site.

**I** Il riduttore tipo I63 viene fornito lubrificato a vita con olio sintetico. Per posizioni V5-V6 contattare il ns. servizio tecnico. Vedi tab.1 per oli e quantità consigliati. In tab.2 sono presenti i carichi radiali e assiali applicabili al riduttore. Per la documentazione completa consulta il nostro sito.

**D** Für die Lebensdauerschmierung ist das Getriebe der Größe I63 mit synthetischem Öl befüllt. Bei Einbaulage V5 oder V6 bitten wir um Rücksprache. In Tabelle 1 ist die Schmiermenge und das empfohlene Schmiermittel angegeben. In Tabelle 2 sind die zulässigen Radial- und Axialbelastungen des Getriebes aufgeführt. Die komplette Dokumentation, Wartungs- und Inbetriebnahmeanleitungen finden Sie unter.

**E** El reductor tamaño I63 se suministra, lubricado de por vida con aceite sintético. Para las posiciones V5 y V6 contactar con nuestro servicio técnico. Ver tabla 1, para cantidades y aceites recomendados. En la tabla 2, se encuentran las cargas radiales y axiales admitidas por el reductor. Para documentación completa, consultar nuestra Web.

Standard	On request				
0.98 LT	0.69 LT	0.69 LT	0.98 LT	0.98 LT	0.98 LT
<b>AGIP</b>	<b>KLUBER</b>		<b>SHELL</b>	<b>MOBIL</b>	
Telium VSF 320	Syntheso D220 EP		Tivela Oil WB	Glygoyl 30 SHC 630	

tab. 1

▪ RADIAL AND AXIAL LOADS			
Output shaft Albero di uscita	$n_2$	FA	FR
	200	360	1800
	150	400	2000
	100	460	2300
	75	500	2500
	50	600	3000
	25	700	3800
	15	800	4000

tab. 2

▪ **SELECT THIS TYPE AND THIS SPECIFIC SIZE ON THE WEB PAGES TO GET COMPLETE TECHNICAL DATA.**  
Selezionare tipo e gandezza specifica nel sito web per la documentazione completa.

Wormbox weight **14.6 kg**  
peso riduttore

PI63**UN**... Basic wormbox  
Riduttore base

M. flanges	Kit code	øF	A
71B14	KI63.4.047	105	97
80B14	KI63.4.046	120	98
90B14	KI63.4.041	140	99

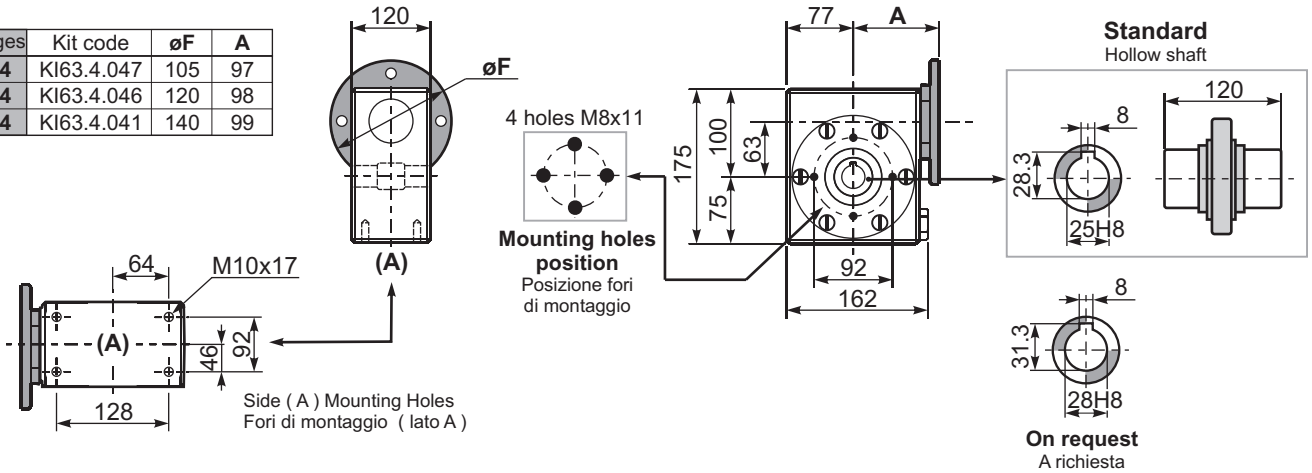

BI63**UN**... Modular base  
Base modulare

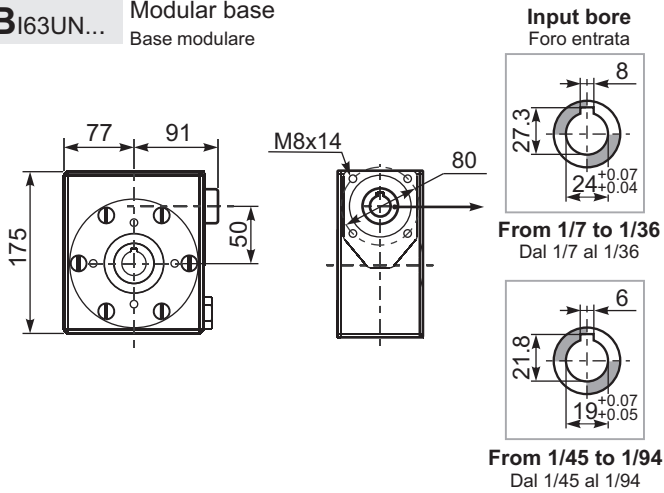

PI63**FL**... Output flange  
Flangia uscita

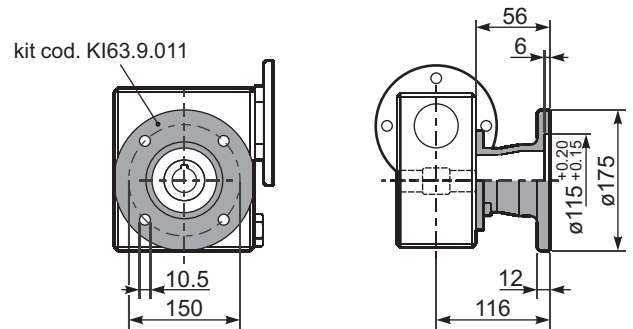

PI63**BR**... Reaction arm  
Braccio di reazione

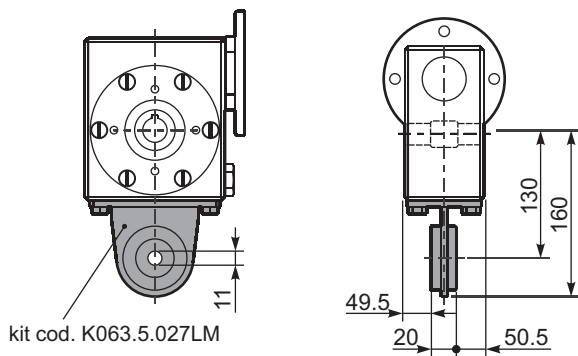

PI63.....**S**... Single Shaft  
Albero lento semplice

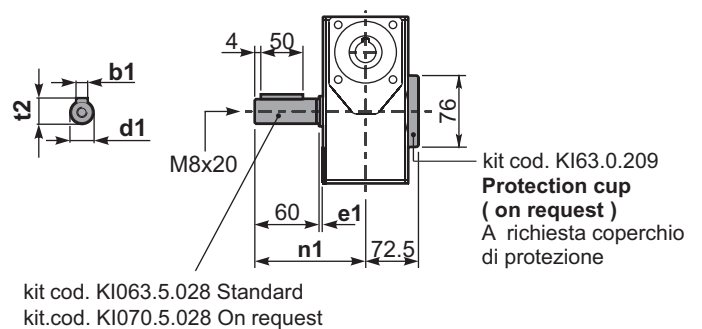

	b1	e1	d1	n1	t2
Standard	8	3.2	25 <sup>-0.005</sup> <sub>-0.020</sub>	121.9	28
On request	8	3.5	28 <sup>-0.005</sup> <sub>-0.020</sub>	122.2	31



#### QUICK SELECTION / Selezione veloce

input speed ( $n_1$ ) = 1400 min<sup>-1</sup>

Output Speed $n_2$ [min <sup>-1</sup> ]	Ratio $i$	Motor power $P_{1M}$ [kW]	Output torque $M_{2M}$ [Nm]	Service factor f.s.	Nominal power $P_{1R}$ [kW]	Nominal torque $M_{2R}$ [Nm]	Available B5 motor flanges		Available B14 motor flanges	Dynamic efficiency	Tooth Module $Mn$ [mm]	Ratios code
							D	E	U			
							80	90	100-112			
200	7	4.0	168	1.5	5.8	245	B	B		88	4.23	01
140	10	4.0	218	1.2	4.9	270	B	B		80	4.2	02
100	14	3.0	223	1.3	3.9	290	B	B		78	4.5	03
70	20	2.2	237	1.2	2.6	280	B	B		79	3.4	04
64	22	2.2	258	1.1	2.4	280	B	B		78	3.1	05
50	28	2.2	315	1.0	2.3	330	B	B		75	4.7	06
37	38	1.5	276	1.2	1.7	320	B	B		71	3.5	07
30	46	1.5	320	1.0	1.4	310	B	B		68	3.1	08
27	52	1.1	258	1.1	1.2	275	B	B		66	2.7	09
21	67	1.1	327	0.8	0.93	275	B	B		65	2.1	10
18.9	74	0.75	220	1.2	0.87	255	B	B		58	1.9	11
14.6	96	0.55	191	1.2	0.66	230	B	B		53	1.5	12

Motor Flanges Available Flange Motore Disponibili    
 B) Supplied with Reduction Bushing Fornito con Bussola di Riduzione    
 B) Available on Request without reduction bushing Disponibile a Richiesta senza Bussola di Riduzione    
 C) Motor Flange Holes Position Posizione Fori Flangia Motore

**EN** Unit I85 is supplied with synthetic oil, providing "long life" lubrication. For mounting position V5-V6 please contact us. See table 1 for lubrication and recommended quantity. In table 2 please see possible radial loads and axial loads on the gearbox. For complete documentation please visit our web site.

**I** Il riduttore tipo I85 viene fornito lubrificato a vita con olio sintetico. Per posizioni V5-V6 contattare il ns. servizio tecnico. Vedi tab.1 per oli e quantità consigliati. In tab.2 sono presenti i carichi radiali e assiali applicabili al riduttore. Per la documentazione completa consulta il nostro sito.

**D** Für die Lebensdauerschmierung ist das Getriebe der Größe I85 mit synthetischem Öl befüllt. Bei Einbaulage V5 oder V6 bitten wir um Rücksprache. In Tabelle 1 ist die Schmiermenge und das empfohlene Schmiermittel angegeben. In Tabelle 2 sind die zulässigen Radial- und Axialbelastungen des Getriebes aufgeführt. Die komplette Dokumentation, Wartungs- und Inbetriebnahmeanleitungen finden Sie unter.

**E** El reductor tamaño I85 se suministra, lubricado de por vida con aceite sintético. Para las posiciones V5 y V6 contactar con nuestro servicio técnico. Ver tabla 1, para cantidades y aceites recomendados. En la tabla 2, se encuentran las cargas radiales y axiales admitidas por el reductor. Para documentación completa, consultar nuestra Web.

Standard		On request			
B3	B6	B7	B8	V5	V6
2.10 LT	1.50 LT	1.50LT	2.10 LT	2.10 LT	2.10 LT
<b>AGIP</b>	<b>KLUBER</b>	<b>SHELL</b>	<b>MOBIL</b>		
Telium VSF 320	Syntheso D220 EP	Tivela Oil WB	Glygoyl 30 SHC 630		

tab. 1

-RADIAL AND AXIAL LOADS			
Output shaft Albero di uscita	$n_2$ [min <sup>-1</sup> ]	FA [N]	FR [N]
200	500	2500	
150	580	2900	
100	600	3000	
75	700	3500	
50	800	4000	
25	1000	5000	
15	1160	5800	

tab. 2

**SELECT THIS TYPE AND THIS SPECIFIC SIZE ON THE WEB PAGES TO GET COMPLETE TECHNICAL DATA.**  
 Selezionare tipo e gandezza specifica nel sito web per la documentazione completa.

Wormbox weight  
peso riduttore **23.3 kg**

PI85UN... Basic wormbox  
Riduttore base

M. flanges	Kit code	øF	A
80-90B5	KI85.4.042	200	118
100-112B14	KI85.4.041	160	116

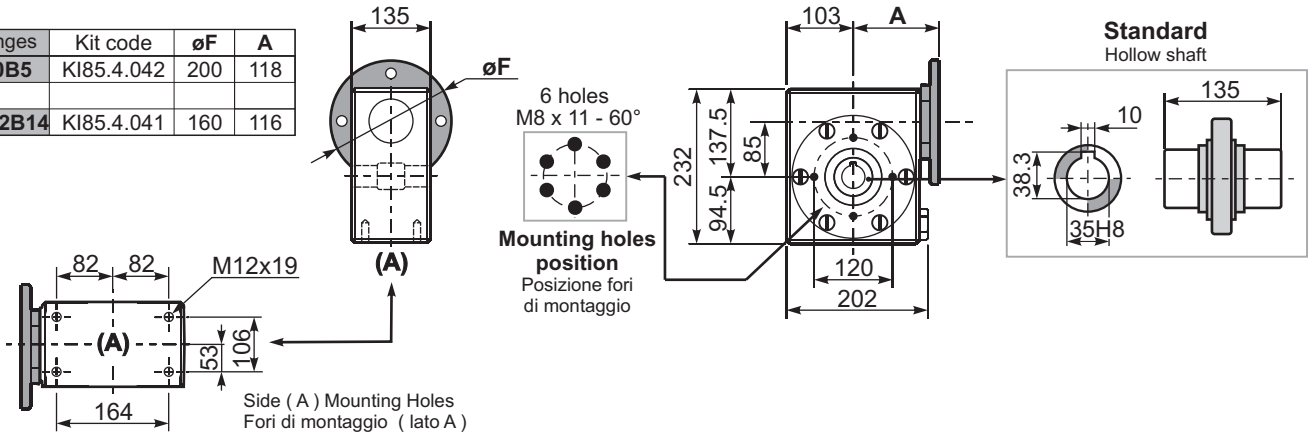

BI85UN... Modular base  
Base modulare

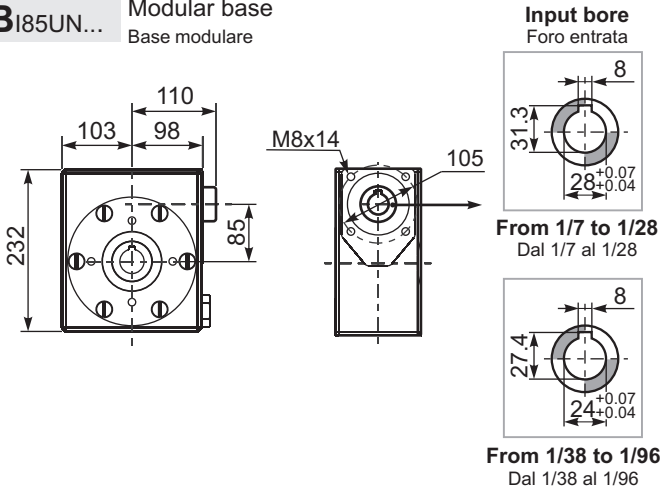

PI85FL... Output flange  
Flangia uscita

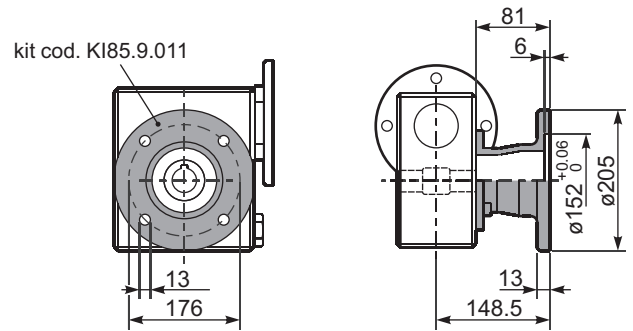

PI85BR... Reaction arm  
Braccio di reazione

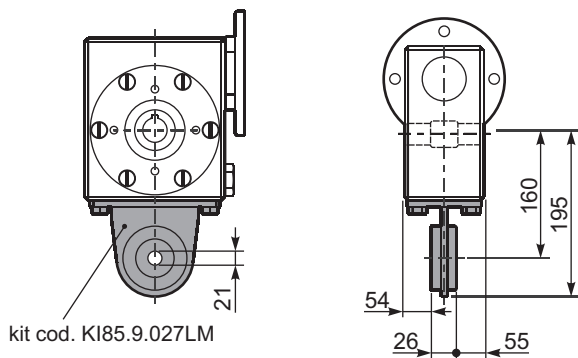

PI85.....S... Single Shaft  
Albero lento semplice

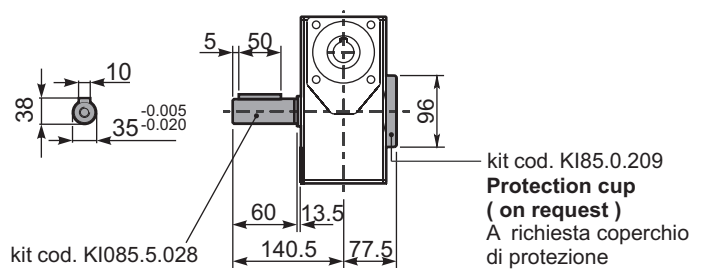

# Stainless steel in line gearboxes

A modular and compact product

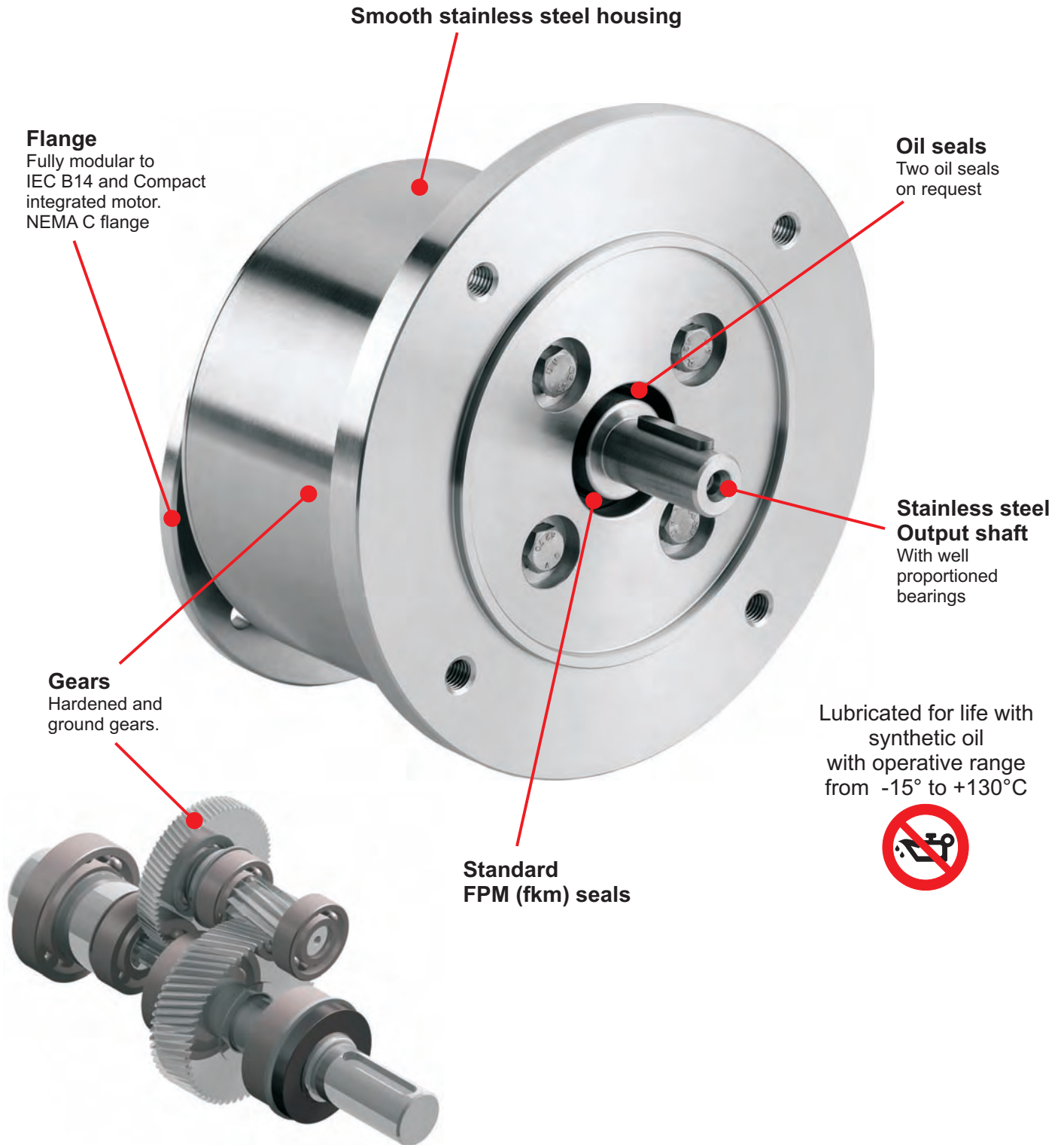

Smooth stainless steel housing

**Flange**

Fully modular to IEC B14 and Compact integrated motor. NEMA C flange

**Oil seals**

Two oil seals on request

**Stainless steel Output shaft**

With well proportioned bearings

**Gears**

Hardened and ground gears.

Standard FPM (fkm) seals

Lubricated for life with synthetic oil with operative range from -15° to +130°C



On page / A pagina / Auf Seite / En la página



Types / Tipi /  
Arten / Tipos



9-5	9-6	9-7	9-8
411I 38Nm	511I 110Nm	402I 150Nm	602I 460Nm

On page / A pagina / Auf Seite / En la página



Types / Tipi /  
Arten / Tipos



M-3							
63B 0.18kw 1/4cv	71A 0.25kw 1/3cv	71B 0.37kw 1/2cv	80A 0.55kw 3/4cv	80B 0.75kw 1cv	90S 1.1kw 1 1/2cv	90L 1.5kw 2cv	100LA 2.2kw 3cv

For : / Per : / Für : / Para :

**Selection guide - fs**  
Guida alla selezione

**Mounting pos. - Lubrication**  
Pos. di montaggio - lubrificazione

**2 - 6 poles selection**  
Selezione 2 - 6 poli

**Radial - axial loads**  
Carichi radiali e assiali

**Reversibility**  
Reversibilità

**Thermal limit**  
Limite termico

**Atex certification**  
Certificazione Atex

**Accessories**  
Accessori

**Download 3D drawings**  
Download disegni 3D

**Interchangeability**  
Intercambiabilità

**Installation and maintenance**  
Installazione, uso e manutenzione

**Spare parts list**  
Liste parti di ricambio

Use our web database to  
get detailed informations,  
always updated on  
each type/size.

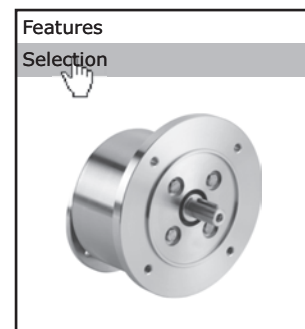

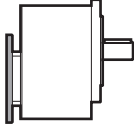
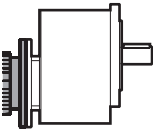
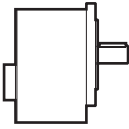
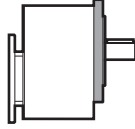
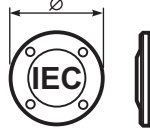
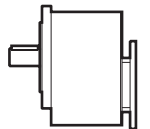
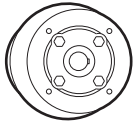
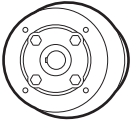
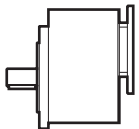
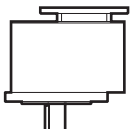
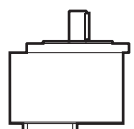
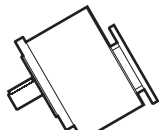
Type - Tipo Typ - Tipo	Size - Grandezza Grösse - Tomaño	Mounting Montaggio Montage Tipo de montaje	Ratio - Rapporto Untersetzung Relación	Output shaft Albero lento Abtriebswelle Eje solida	Output flange Flangia uscita Ausgangsflansch Brida en salida	Motor size Grandezza motore Motor Grösse Tamaño motor	Mounting position Posizione montaggio Einbaulage Position de montaje
<b>P</b>	<b>411I</b>	<b>-F</b>	<b>1.57</b>	<b>C</b>	<b>4</b>	<b>Q</b>	<b>B5</b>
 <p><b>P</b></p>  <p><b>M</b></p>  <p><b>B</b> Only for local assembly</p>	<p><b>411I</b> <b>511I</b></p> <p><b>402I</b> <b>602I</b></p>	 <p><b>-F</b></p> <p>Foot mounting is not available</p>	<p>See technical data table</p> <p>Vedi tabelle dati tecnici.</p> <p>Ver tabla datos técnicos</p>	<p>→ STANDARD</p> <p>411I</p> <p><b>S</b> ⇒ <math>\varnothing 14</math> <b>C</b> ⇒ <math>\varnothing 19</math></p> <p>511I</p> <p><b>E</b> ⇒ <math>\varnothing 24</math> <b>G</b> ⇒ <math>\varnothing 28</math></p> <p>402I</p> <p><b>E</b> ⇒ <math>\varnothing 24</math></p> <p>602I</p> <p><b>I</b> ⇒ <math>\varnothing 35</math></p>	<p>411I</p> <p><b>3</b> ⇒ <math>\varnothing 160</math> <b>4</b> ⇒ <math>\varnothing 200</math></p> <p>511I</p> <p><b>4</b> ⇒ <math>\varnothing 200</math> <b>5</b> ⇒ <math>\varnothing 250</math></p> <p>402I</p> <p><b>4</b> ⇒ <math>\varnothing 200</math></p> <p>602I</p> <p><b>5</b> ⇒ <math>\varnothing 250</math></p>	 <p>411I - 402I</p> <p><b>Q</b> 71B14 (<math>\varnothing 105</math>) <b>R</b> 80B14 (<math>\varnothing 120</math>) <b>T</b> 90B14 (<math>\varnothing 140</math>)</p> <p>511I - 602I</p> <p><b>R</b> 80B14 (<math>\varnothing 120</math>) <b>T</b> 90B14 (<math>\varnothing 140</math>) <b>U</b> 100-112 B14 (<math>\varnothing 160</math>)</p> <p>Without flange Senza flangia</p> <p>411I - 402I</p> <p><b>1</b> ⇒ <math>\varnothing 14</math> (71B5) <b>2</b> ⇒ <math>\varnothing 19</math> (80B5) <b>3</b> ⇒ <math>\varnothing 24</math> (90B5)</p> <p>511I - 602I</p> <p><b>2</b> ⇒ <math>\varnothing 19</math> (80B5) <b>3</b> ⇒ <math>\varnothing 24</math> (90B5) <b>4</b> ⇒ <math>\varnothing 28</math> (100B5)</p>	 <p><b>B5</b> STANDARD</p>  <p><b>B6</b></p>  <p><b>B7</b></p>  <p><b>B8</b></p>  <p><b>V1</b></p>  <p><b>V3</b></p>  <p><b>V8</b></p>

## On request

**A** Double input / output oil seals

**B** Food lube

- B5 is supplied with standard oil quantity

- Please specify in the order if you required other mounting positions



POTENZA RICHIESTA / REQUIRED POWER / ERFORDERLICHE LEISTUNG / POTENCIA NECESARIA

Lifting / sollevamento / hubantriebe / elevación

$$P \text{ [KW]} = \frac{M \text{ [Kg]} \cdot g \text{ [9.81]} \cdot v \text{ [m / s]}}{1000}$$

Rotation / rotazione / drehung / rotation

$$P \text{ [KW]} = \frac{M \text{ [Nm]} \cdot n \text{ [rpm]}}{9550}$$

Linear movement / traslazione / linearbewegung / translacion

$$P \text{ [KW]} = \frac{F \text{ [N]} \cdot v \text{ [m / s]}}{1000}$$

TORQUE / COPPIA / DREHMOMENT / PAR

$$M \text{ [Nm]} = \frac{9550 \cdot P \text{ [KW]}}{n \text{ [rpm]}}$$

$$M \text{ [lb in]} = \frac{63030 \cdot P \text{ [HP]}}{n \text{ [rpm]}}$$

RADIAL LOADS / CARICHI RADIALI / RADIALE - UND AXIALLASTEN / CARGA RADIAL Y AXIAL

- Radial load generated by external transmissions keyed onto input and/or output shafts.
- Forza radiale generata da organi di trasmissione calettati sugli alberi di ingresso e/o uscita.
- Belastungen der Antriebs- bzw. Abtriebswellen durch von aussen eingebrachte Radiallasten.
- Cargas radiales, generada por transmisiones externas, aplicadas sobre los ejes de entrada y/o salida

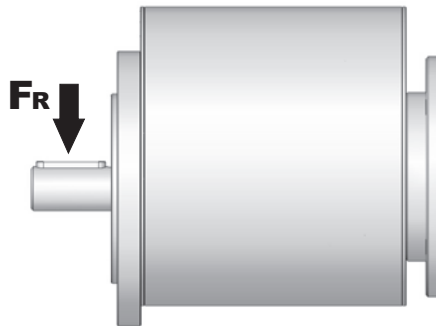

	$F_R \text{ [N]} = \frac{M \text{ [Nm]} \cdot 2000}{d \text{ [mm]}} \cdot f_k$	$F_R \text{ [N]} = \frac{M \text{ [lb in]} \cdot 8.9}{d \text{ [in]}} \cdot f_k$
<b>M</b>	Momento torcente / Output torque / Abtriebsdrehmoment / Par torsion	
<b>d</b>	Diametro primitivo / Diam. of driving element / Durchmesser der Abtriebseinheit / Diámetro primitivo	
<b>f<sub>k</sub></b>	Coefficiente di trasformazione / Factor / Faktor / Coefficiente de transmisión <b>1.15</b> Ingranaggi / Gearwheels / Zahnrad / Engranaje <b>1.25</b> Catena / Chain sprochets / Antriebskette / Cadena <b>1.75</b> Cinghia Trapezoidale / Narrow v-belt pulley / Keilriemen / Correa trapezoidal <b>2.50</b> Cinghia piatta / Flat-belt pulley / Flachzahnriem. / Correa plana	

- If your application requires higher radial loads, contact our technical office. Higher load may be possible.
- Nel caso la vostra applicazione richieda carichi radiali superiori consultare il nostro ufficio tecnico, valori maggiori possono essere accettati.
- Wenn Ihre Anwendung höhere Radialbelastungen erfordert, so wenden Sie sich bitte an unser technischen Büro.
- En el caso en que una aplicación exija una carga radial superior a la especificada en el catálogo, consultar a nuestra oficinas técnica.

How to select a gearbox / Come selezionare un riduttore  
Wie wählt man ein Getriebe / Cómo seleccionar un reductor

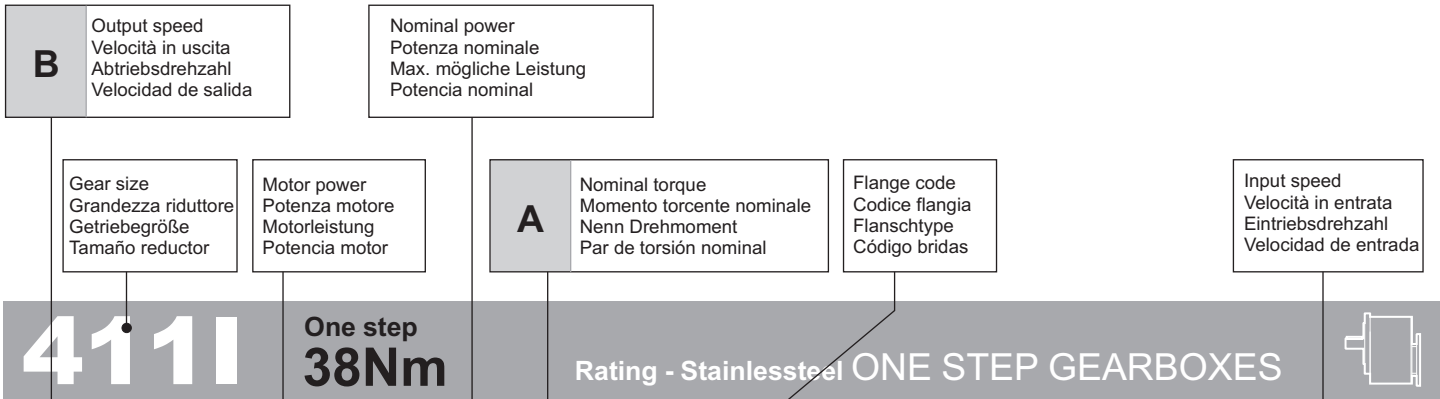

**QUICK SELECTION / Selezione velocità** input speed ( $n_1$ ) = 1400 min<sup>-1</sup>

Output Speed $n_2$ [min <sup>-1</sup> ]	Ratio $i$	Motor power $P_{1M}$ [kW]	Output torque $M_{2M}$ [Nm]	Service factor f.s.	Nominal power $P_{1R}$ [kW]	Nominal torque $M_{2R}$ [Nm]	B5 motor flanges not available				Available B14 motor flanges			Output Shaft 	Ratios code 	
							-	-	-	-	Q	R	T			
892	1.57	1.5	15.7	1.3	1.90	20	-	-	-	-	71	80	90	2844	standard Ø19	-
493	2.84	1.5	28.4	1.2	1.84	35	-	-	-	-	C	C	-	1954		-
426	3.29	1.5	32.9	1.2	1.73	38	-	-	-	-	C	C	-	1756		-
362	3.87	1.5	38.7	1.0	1.54	40	-	-	-	-	C	C	-	1558		-



**fs**

Type of load and starts per hour Tipo di carico e avviamenti per ora		Oper. hours per day Ore di funz. giorn.		
		3 h	10 h	24 h
Continuous or intermittent appl. with start / hour Applicazione cont. o interm. con n.ro operazioni/ora	Uniform / Uniforme	0.8	1	1.25
	Moderate / Moderato	1	1.25	1.5
	Heavy / Forte	1.25	1.5	1.75
Intermittent application with start / hour Applicazione intermittente con n.ro operazioni/ora	Uniform / Uniforme	1	1.25	1.5
	Moderate / Moderato	1.25	1.5	1.75
	Heavy / Forte	1.5	1.75	2.15

**D** Motor flange available  
Flange disponibili  
Erhältliche Motorflansche  
Bridas disponibles

<b>B)</b>	Mounting with reduction ring Montaggio con boccia di riduzione Reduzierhülsen Montaje con casquillo de reducción	
<b>C)</b>	Motor flangeholes position/terminal box position Posizione fori flangia/basetta motore Bohrungsposition am Motorflansch/-sockel Posición agujeros brida / base motor	
<b>B)</b>	Available without reduction bushes Disponibile anche senza boccia Auch ohne Reduzierbuchse verfügbar Disponible tambien sin casquillo	

<b>A</b>	Select required torque (according to service factor)	Seleziona la coppia desiderata (comprensiva del fattore di servizio)	Max. Drehmoment in Bezug zum Betriebsfaktor	Seleccionar el par deseado (incluyendo el factor de servicio)
<b>B</b>	Select output speed	Seleziona la velocità in uscita	Ausgewählte Abtriebsdrehzahl	Seleccionar la velocidad de salida
<b>C</b>	On the same line of selected geared motor, you can find the gear ratio	Sulla riga corrispondente alla motorizzazione prescelta si può rilevare il rapporto di riduzione	Auf der gleichen Linie wie die ausgewählte Motorleistung steht auch die Getriebeuntersetzung	En la línea correspondiente al motor preseleccionado es posible encontrar la relación de reducción
<b>D</b>	Select motor flange available (if requested)	Scegli la flangia disponibile (se richiesta)	Erhältliche Motorflansche (auf Anfrage)	Seleccionar la brida disponible (sobre pedido)



QUICK SELECTION / Selezione veloce							input speed (n <sub>1</sub> ) = 1400 min <sup>-1</sup>									
Output Speed n <sub>2</sub> [min <sup>-1</sup> ]	Ratio i	Motor power P <sub>1M</sub> [kW]	Output torque M <sub>2M</sub> [Nm]	Service factor f.s.	Nominal power P <sub>1R</sub> [kW]	Nominal torque M <sub>2R</sub> [Nm]	B5 motor flanges not available				Available B14 motor flanges			Output Shaft 	Ratios code 	
							-	-	-	-	Q	R	T			
892	1.57	1.5	15.7	1.3	1.90	20	-	-	-	-	71	80	90	2844	standard ø19  On request ø14	-
493	2.84	1.5	28.4	1.2	1.84	35	-	-	-	-	-	-	1954			
426	3.29	1.5	32.9	1.2	1.73	38	-	-	-	-	-	-	1756			
362	3.87	1.5	38.7	1.0	1.54	40	-	-	-	-	-	-	1558			
303	4.62	1.5	46.1	1.0	1.54	47	-	-	-	-	-	-	1360			
222	6.30	1.1	46.0	1.0	1.10	46	-	-	-	-	-	-	1063			
170	8.22	0.55	30.4	1.2	0.69	38	-	-	-	-	-	-	974			
130	10.86	0.37	26.8	1.0	0.38	28	-	-	-	-	-	-	776			

The dynamic efficiency is **0.98** for all ratios

- Motor Flanges Available**  
Flange Motore Disponibili
- B) Supplied with Reduction Bushing**  
Fornito con Bussola di Riduzione
- B) Available on Request without reduction bushing**  
Disponibile a Richiesta senza Bussola di Riduzione
- C) Motor Flange Holes Position**  
Posizione Fori Flangia Motore

**EN** Unit **4111** is supplied with synthetic oil for lifetime lubrication, no maintenance is necessary.  
For complete documentation please visit our web site.

**I** Il riduttore **4111** viene fornito completo di olio sintetico per la lubrificazione permanente e non necessita di alcuna manutenzione.  
Per la documentazione completa consulta il nostro sito.

**D** Das Getriebe **4111** ist mit synthetischem Öl gefüllt und ist lebensdauergeschmiert.  
Die komplette Dokumentation, Wartungs- und Inbetriebnahmeanleitungen finden Sie unter.

**E** El reductor tamaño **4111** se suministra, lubricado de por vida con aceite sintético y no requieren mantenimiento alguna.  
Para documentación completa, consultar nuestra Web.

### Life lubrication - Fully synthetic oil

Mounting position to be specified - B6-B7-B8-V1-V3-V8

### RADIAL AND AXIAL LOADS

#### Output shaft

Albero di uscita

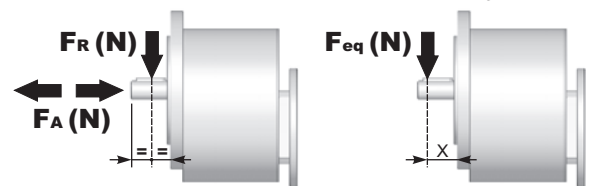

$$F_{eq} = F_R \cdot \frac{40}{X+20}$$

n <sub>2</sub>	FA	FR	n <sub>2</sub>	FA	FR	n <sub>2</sub>	FA	FR
700	182	910	400	230	1150	200	290	1450
600	100	1000	300	250	1250	140	320	1600

P4111-F... Output flange  
flangia di uscita

**Wormbox weight**  
peso riduttore **8.2 kg**

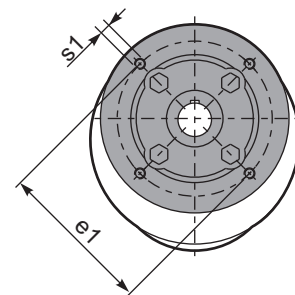
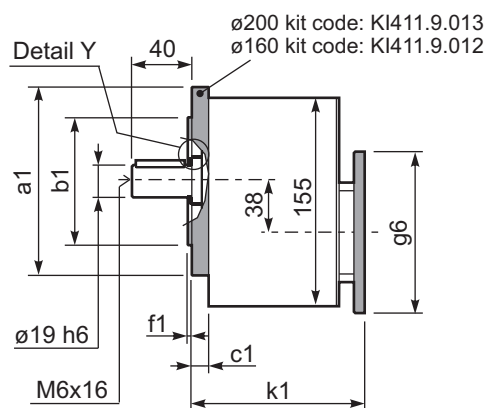
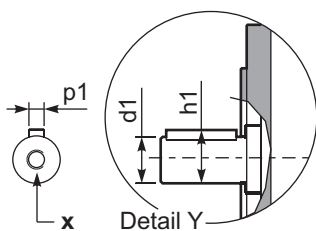

#### Output shafts / albero di uscita

	Shaft - d1	p1	h1	x
<b>Standard</b>	ø 19x40	6	21.5	M6x16
*On request A richiesta	ø 14x30	5	16	M5x13

#### Output flanges / flange di uscita

	a1 ø	b1	c1	e1	f1	s1
<b>Standard</b>	200	130	12.5	165	3.5	M10x12
*On request A richiesta	160	110	12.5	130	3.5	M8x12

#### Input flanges / flange di entrata

	g6	k1	kit code
	105 (71B14)	127.5	KI63.4.047
	120 (80B14)	128.5	KI63.4.046
	140 (90B14)	129.5	KI63.4.041

\* Please contact us for minimum quantity / Contattarci per quantità minima.

**SELECT THIS TYPE AND THIS SPECIFIC SIZE ON THE WEB PAGES TO GET COMPLETE TECHNICAL DATA.**  
Selezionare tipo e grandezza specifica nel sito web per la documentazione completa.



### QUICK SELECTION / Selezione veloce

input speed ( $n_1$ ) = 1400 min<sup>-1</sup>

Output Speed $n_2$ [min <sup>-1</sup> ]	Ratio $i$	Motor power $P_{1M}$ [kW]	Output torque $M_{2M}$ [Nm]	Service factor f.s.	Nominal power $P_{1R}$ [kW]	Nominal torque $M_{2R}$ [Nm]	motor flanges B5 not available				Available B14 motor flanges				Output Shaft 	Ratios code	
							-	-	-	-	R	T	U	-			
1077	1.30	4	34	1.2	4.6	40	-	-	-	-	80	90	100	112	3039	standard ø28  On request ø24	-
571	2.45	4	64	1.1	4.3	70	-	-	-	-	-	-	-	2049			
423	3.31	4	87	1.0	4.1	90	-	-	-	-	-	-	-	1653			
325	4.31	4	113	1.0	3.8	110	-	-	-	-	-	-	-	1356			
266	5.27	3	104	1.1	3.1	110	-	-	-	-	-	-	-	1158			
184	7.63	2.2	111	1.0	2.2	110	-	-	-	-	-	-	-	861			
133	10.50	1.1	77	1.0	1.1	80	-	-	-	-	-	-	-	663			

The dynamic efficiency is 0.98 for all ratios

**Motor Flanges Available**  
Flange Motore Disponibili

**B) Supplied with Reduction Bushing**  
Fornito con Bussola di Riduzione

**B) Available on Request without reduction bushing**  
Disponibile a Richiesta senza Bussola di Riduzione

**C) Motor Flange Holes Position**  
Posizione Fori Flangia Motore

**EN** Unit 5111 is supplied with synthetic oil for lifetime lubrication, no maintenance is necessary.  
For complete documentation please visit our web site.

**I** Il riduttore 5111 viene fornito completo di olio sintetico per la lubrificazione permanente e non necessita di alcuna manutenzione.  
Per la documentazione completa consulta il nostro sito.

**D** Das Getriebe 5111 ist mit synthetischem Öl gefüllt und ist lebensdauergeschmiert.  
Die komplette Dokumentation, Wartungs- und Inbetriebnahmeanleitungen finden Sie unter.

**E** El reductor tamaño 5111 se suministra, lubricado de por vida con aceite sintético y no requieren mantenimiento alguna.  
Para documentación completa, consultar nuestra Web.

### Life lubrication - Fully synthetic oil

Mounting position to be specified - B6-B7-B8-V1-V3-V8

### RADIAL AND AXIAL LOADS

#### Output shaft

Albero di uscita

$$F_{eq} = F_R \cdot \frac{52.5}{X+22.5}$$

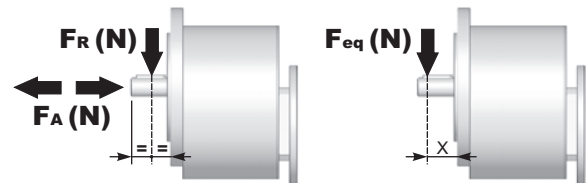

$n_2$	FA	FR	$n_2$	FA	FR	$n_2$	FA	FR
700	294	1470	400	370	1850	200	460	2300
600	320	1600	300	400	2000	140	510	2550

P5111-F... Output flange  
flangia di uscita

**Wormbox weight**  
peso riduttore **14.0 kg**

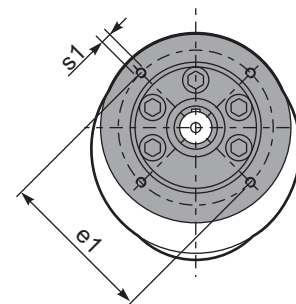
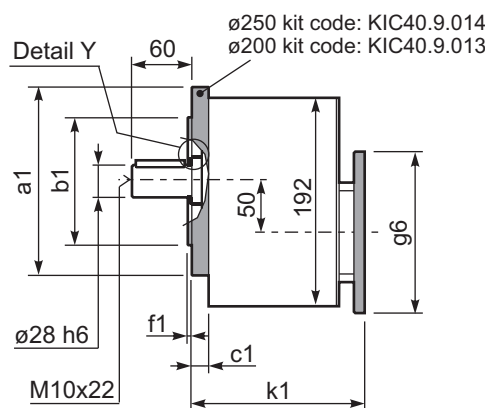
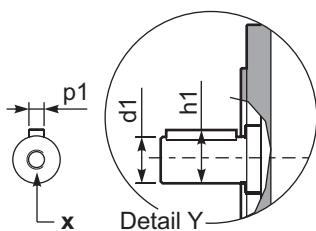

#### Output shafts / albero di uscita

	Shaft - d1	p1	h1	x
Standard	ø 28x60	8	31	M10x22
*On request A richiesta	ø 24x50	8	27	M6x16

#### Output flanges / flange di uscita

	a1 ø	b1	c1	e1	f1	s1
Standard	250	180	13.5	215	3.5	M12x13
*On request A richiesta	200	130	13.5	165	3.5	M10x13

#### Input flanges / flange di entrata

	g6	k1	kit code
	120 (80B14)	150.5	KIC50.4.046
	140 (90B14)	150.5	KIC50.4.045
	160 (100B14)	161.5	KIC50.4.047

\* Please contact us for minimum quantity / Contattarci per quantità minima.

**SELECT THIS TYPE AND THIS SPECIFIC SIZE ON THE WEB PAGES TO GET COMPLETE TECHNICAL DATA.**  
Selezionare tipo e grandezza specifica nel sito web per la documentazione completa.



#### QUICK SELECTION / Selezione veloce

input speed ( $n_1$ ) = 1400 min<sup>-1</sup>

Output Speed $n_2$ [min <sup>-1</sup> ]	Ratio $i$	Motor power $P_{1M}$ [kW]	Output torque $M_{2M}$ [Nm]	Service factor $f.s.$	Nominal power $P_{1R}$ [kW]	Nominal torque $M_{2R}$ [Nm]	B5 motor flanges not available				Available B14 motor flanges				Output Shaft		
							-	-	-	-	Q	R	T	-			Ratio code
398	<b>3.52</b>	1.5	34	2.3	<b>3.5</b>	<b>80</b>	-	-	-	-	C	C	-	-	2821	standard ø24	-
320	<b>4.37</b>	1.5	43	2.1	<b>3.1</b>	<b>90</b>	-	-	-	-	C	C	-	-	2818		
252	<b>5.55</b>	1.5	54	1.8	<b>2.8</b>	<b>100</b>	-	-	-	-	C	C	-	-	2813		
220	<b>6.36</b>	1.5	62	1.5	<b>2.3</b>	<b>95</b>	-	-	-	-	C	C	-	-	1921		
191	<b>7.33</b>	1.5	72	1.7	<b>2.5</b>	<b>120</b>	-	-	-	-	C	C	-	-	2812		
177	<b>7.89</b>	1.5	77	1.6	<b>2.3</b>	<b>120</b>	-	-	-	-	C	C	-	-	1918		
139	<b>10.06</b>	1.5	99	1.5	<b>2.3</b>	<b>150</b>	-	-	-	-	C	C	-	-	1913		
120	<b>11.66</b>	1.5	114	1.5	<b>2.3</b>	<b>174</b>	-	-	-	-	C	C	-	-	1713		
106	<b>13.26</b>	1.5	130	1.2	<b>1.8</b>	<b>160</b>	-	-	-	-	C	C	-	-	1912		
102	<b>13.68</b>	1.5	134	1.1	<b>1.6</b>	<b>144</b>	-	-	-	-	C	C	-	-	1513		
91	<b>15.37</b>	1.5	151	1.1	<b>1.6</b>	<b>160</b>	-	-	-	-	C	C	-	-	1712		
86	<b>16.20</b>	1.5	159	0.9	<b>1.3</b>	<b>138</b>	-	-	-	-	C	C	-	-	1910		
78	<b>18.04</b>	1.5	177	0.9	<b>1.4</b>	<b>160</b>	-	-	-	-	C	C	-	-	1512		
74	<b>18.80</b>	1.1	135	1.0	<b>1.1</b>	<b>138</b>	-	-	-	-	C	C	-	-	1710		
65	<b>21.54</b>	1.1	155	1.0	<b>1.1</b>	<b>160</b>	-	-	-	-	C	C	-	-	1312		
63	<b>22.29</b>	1.1	161	1.0	<b>1.1</b>	<b>167</b>	-	-	-	-	C	C	-	-	1013		
53	<b>26.30</b>	0.75	129	1.1	<b>0.80</b>	<b>138</b>	-	-	-	-	C	C	-	-	1310		
47.6	<b>29.40</b>	0.75	144	1.1	<b>0.83</b>	<b>160</b>	-	-	-	-	C	C	-	-	1012		
39	<b>35.91</b>	0.55	129	1.1	<b>0.59</b>	<b>138</b>	-	-	-	-	C	C	-	-	1010		
36.5	<b>38.37</b>	0.55	138	1.2	<b>0.64</b>	<b>160</b>	-	-	-	-	C	C	-	-	912		
29.9	<b>46.86</b>	0.55	169	0.8	<b>0.45</b>	<b>138</b>	-	-	-	-	C	C	-	-	910		
27.6	<b>50.67</b>	0.37	123	1.1	<b>0.40</b>	<b>132</b>	-	-	-	-	C	C	-	-	712		
22.6	<b>61.88</b>	0.37	150	0.9	<b>0.34</b>	<b>138</b>	-	-	-	-	C	C	-	-	710		

The dynamic efficiency is **0.96** for all ratios

Motor Flanges Available  
Flange Motore Disponibili

B) Supplied with Reduction Bushing  
Fornito con Bussola di Riduzione

B) Available on Request without reduction bushing  
Disponibile a Richiesta senza Bussola di Riduzione

C) Motor Flange Holes Position  
Posizione Fori Flangia Motore

Life lubrication - Fully synthetic oil  
Mounting position to be specified - B6-B7-B8-V1-V3-V8

- EN** Unit 4021 is supplied with synthetic oil for lifetime lubrication, no maintenance is necessary. For complete documentation please visit our web site.
- I** Il riduttore 4021 viene fornito completo di olio sintetico per la lubrificazione permanente e non necessita di alcuna manutenzione. Per la documentazione completa consulta il nostro sito.
- D** Das Getriebe 4021 ist mit synthetischem Öl gefüllt und ist lebensdauergeschmiert. Die komplette Dokumentation, Wartungs- und Inbetriebnahmeanleitungen finden Sie unter.
- E** El reductor tamaño 4021 se suministra, lubricado de por vida con aceite sintético y no requieren mantenimiento alguna. Para documentación completa, consultar nuestra Web.

### RADIAL AND AXIAL LOADS

Output shaft  
Albero di uscita

$F_{eq} = F_R \cdot \frac{46}{X+21}$

$n_2$	FA	FR	$n_2$	FA	FR	$n_2$	FA	FR
300	310	1550	140	406	2030	70	540	2700
250	330	1650	120	448	2240	40	600	3000
200	360	1800	85	480	2400	15	600	3000

P4021-F... Output flange  
flangia di uscita

Wormbox weight  
peso riduttore **11.4 kg**

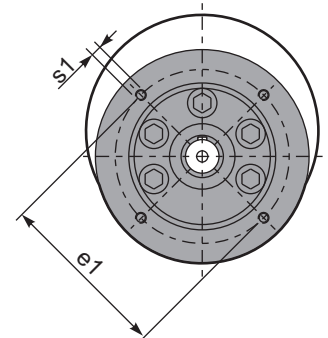
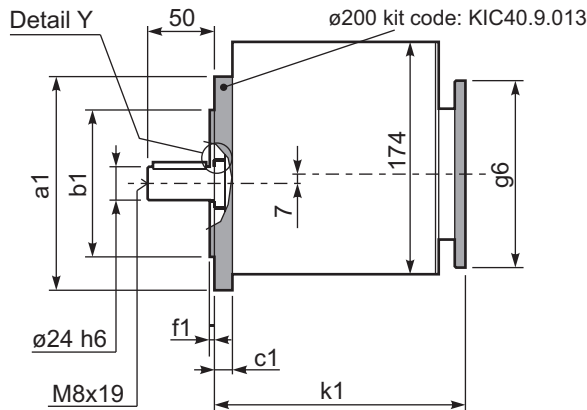
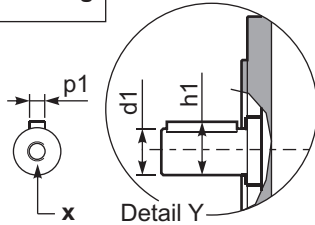

#### Output shafts / albero di uscita

	Shaft - d1	p1	h1	x
Standard	ø 24x50	8	27	M8x19
*On request A richiesta	-	-	-	-

#### Output flanges / flange di uscita

	a1	ø	b1	c1	e1	f1	s1
Standard	200	130	13.5	165	3.5	M10x13	
*On request A richiesta	-	-	-	-	-	-	-

#### Input flanges / flange di entrata

	g6	k1	kit code
	105 (71B14)	186	KI63.4.047
	120 (80B14)	187	KI63.4.046
	140 (90B14)	188	KI63.4.041



#### QUICK SELECTION / Selezione veloce

input speed (n<sub>1</sub>) = 1400 min<sup>-1</sup>

Output Speed n <sub>2</sub> [min <sup>-1</sup> ]	Ratio i	Motor power P <sub>1M</sub> [kW]	Output torque M <sub>2M</sub> [Nm]	Service factor f.s.	Nominal power P <sub>1R</sub> [kW]	Nominal torque M <sub>2R</sub> [Nm]	motor flanges B5 not available				Available B14 motor flanges				Output Shaft		
							-	-	-	-	R	T	U	-			Ratio code
388	<b>3.61</b>	4	93	1.8	7.0	165	-	-	-	-	80	90	100	112	3018	standard ø35	-
331	<b>4.23</b>	4	108	1.8	7.2	200	-	-	-	-	-	-	-	3016			
279	<b>5.01</b>	4	129	1.9	7.3	240	-	-	-	-	-	-	-	3014			
231	<b>6.07</b>	4	156	1.7	6.8	270	-	-	-	-	-	-	-	3012			
206	<b>6.81</b>	4	174	1.9	7.6	340	-	-	-	-	-	-	-	2018			
176	<b>7.96</b>	4	204	1.8	7.1	370	-	-	-	-	-	-	-	2016			
148	<b>9.45</b>	4	242	1.7	6.5	400	-	-	-	-	-	-	-	2014			
122	<b>11.43</b>	4	293	1.4	5.3	400	-	-	-	-	-	-	-	2012			
99	<b>14.21</b>	4	372	1.1	4.3	400	-	-	-	-	-	-	-	2010			
84	<b>16.62</b>	4	435	1.2	4.6	501	-	-	-	-	-	-	-	1314			
70	<b>20.10</b>	4	527	0.9	3.8	499	-	-	-	-	-	-	-	1112			
57	<b>24.61</b>	3	483	1.0	3.1	492	-	-	-	-	-	-	-	1312			
56	<b>24.98</b>	3	491	0.8	2.4	400	-	-	-	-	-	-	-	1310			
47.6	<b>29.41</b>	2.2	424	1.0	2.3	440	-	-	-	-	-	-	-	814			
39.3	<b>35.58</b>	1.85	431	1.2	2.1	499	-	-	-	-	-	-	-	812			
34.6	<b>40.50</b>	1.1	292	1.1	1.2	310	-	-	-	-	-	-	-	614			
31.7	<b>44.23</b>	1.5	434	0.9	1.4	400	-	-	-	-	-	-	-	810			
28.6	<b>49.00</b>	1.1	353	1.0	1.1	368	-	-	-	-	-	-	-	612			
23.0	<b>60.90</b>	1.1	439	0.9	1.0	400	-	-	-	-	-	-	-	610			

The dynamic efficiency is 0.96 for all ratios

**Motor Flanges Available**  
Flange Motore Disponibili

**B) Supplied with Reduction Bushing**  
Fornito con Bussola di Riduzione

**B) Available on Request without reduction bushing**  
Disponibile a Richiesta senza Bussola di Riduzione

**C) Motor Flange Holes Position**  
Posizione Fori Flangia Motore

#### Life lubrication - Fully synthetic oil

Mounting position to be specified - B6-B7-B8-V1-V3-V8

- EN** Unit 6021 is supplied with synthetic oil for lifetime lubrication, no maintenance is necessary. For complete documentation please visit our web site.
- I** Il riduttore 6021 viene fornito completo di olio sintetico per la lubrificazione permanente e non necessita di alcuna manutenzione. Per la documentazione completa consulta il nostro sito.
- D** Das Getriebe 6021 ist mit synthetischem Öl gefüllt und ist lebensdauergeschmiert. Die komplette Dokumentation, Wartungs- und Inbetriebnahmeanleitungen finden Sie unter.
- E** El reductor tamaño 6021 se suministra, lubricado de por vida con aceite sintético y no requiren mantenimiento alguna. Para documentación completa, consultar nuestra Web.

#### RADIAL AND AXIAL LOADS

Output shaft  
Albero di uscita

$$F_{eq} = F_R \cdot \frac{60.5}{X+25.5}$$

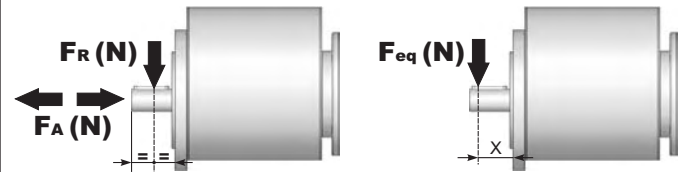

n <sub>2</sub>	FA	FR	n <sub>2</sub>	FA	FR	n <sub>2</sub>	FA	FR
300	560	2800	140	740	3700	70	890	4200
250	600	3000	120	760	3800	40	1160	5800
200	640	3200	85	840	4000	15	1300	6500

**P6021-F** ... Output flange  
flangia di uscita

**Wormbox weight**  
peso riduttore **24.0 kg**

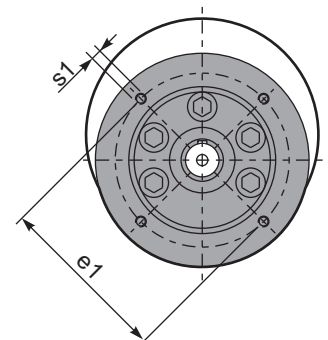
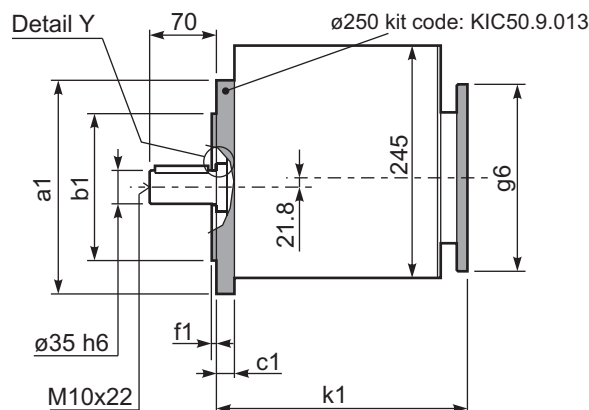
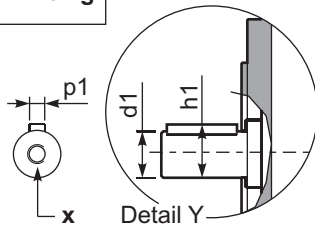

Output shafts / albero di uscita

	Shaft - d1	p1	h1	x
<b>Standard</b>	ø 35x70	10	38	M10x22
*On request A richiesta	-	-	-	-

Output flanges / flange di uscita

	a1	ø	b1	c1	e1	f1	s1
<b>Standard</b>	250	180	19.5	215	4	M12x19	
*On request A richiesta	-	-	-	-	-	-	-

Input flanges / flange di entrata

	g6	k1	kit code
	120 (80B14)	251	KIC50.4.046
	140 (90B14)	251	KIC50.4.045
	160 (100B14)	262	KIC50.4.047

**SELECT THIS TYPE AND THIS SPECIFIC SIZE ON THE WEB PAGES TO GET COMPLETE TECHNICAL DATA.**  
Selezionare tipo e gandezza specifica nel sito web per la documentazione completa.

# Stainlesssteel IEC B14 motors

## Features

- 1) 300 Series Stainless Steel Construction.
- 2) Inverter duty
- 3) Washdown Duty Applications.
- 4) BISSC Certified.
- 5) Corrosion Resistant.
- 6) Laser Etched Nameplate.
- 7) Oversized Bearings on both ends  
c/w Locked Drive-end Bearing  
Construction.
- 8) Oversized Conduit Box c/w Lead  
Seal.
- 9) Drill & Tapped Drains.
- 10) T-Drain included.
- 11) Double Lip Contact Seals.

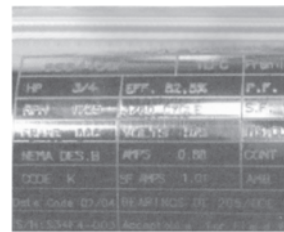
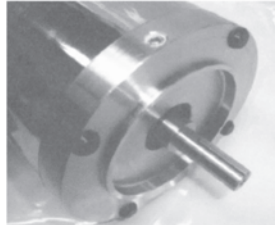
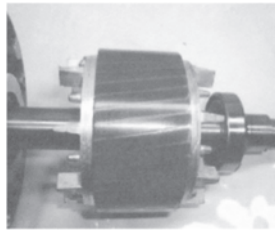

**B14**

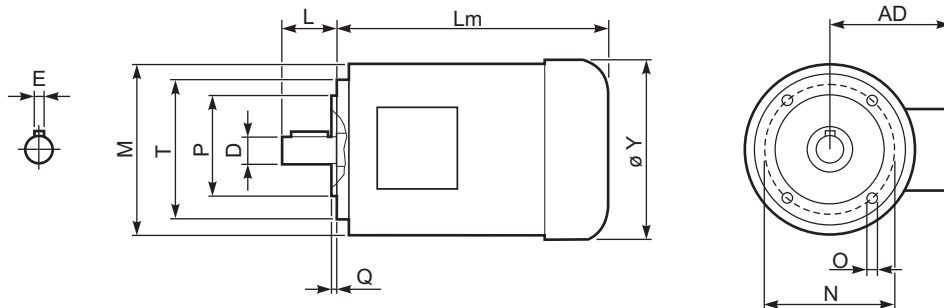

**Outside dimensions may be different according to manufacturers.**

Le dimensioni esterne sono indicative, possono variare tra i vari costruttori.

	4 poli / poles														Kg	
	kW	Nm	A (400V)	D	E	L	Lm	Y	AD	P	N	M	T	O		Q
<b>63</b>	<b>0.18</b>	1.30	0.69	11	4	23.5	252	128	106	60	75	114	90	M5	2.5	8.2
<b>71</b>	<b>0.25</b>	1.70	0.91	14	5	30.5	228	146	115	70	85	134	105	M6	2.5	8.3
	<b>0.37</b>	2.52	1.14				252									10.4
<b>80</b>	<b>0.55</b>	3.77	1.51	19	6	40	300	158	115	80	100	144	120	M6	3	17.5
	<b>0.75</b>	5.11	2.57				300									
<b>90</b>	<b>1.1</b>	7.45	2.78	24	8	50	321	174	135	95	115	165	140	M8	3	22.4
	<b>1.5</b>	10.2	3.61				367									27.6
<b>100</b>	<b>2.2</b>	14.8	5.07	28	8	60	374	203	150	110	130	190	160	M8	3.5	33.5

Tecnical data
- Voltage: 230 / 400V
- Phase: 3
- Frequency: 50Hz
- Poles: 4
- International protections : IP 65
- Insulation class: F
- Duty: S1

### Please Read Carefully

The following WARNING and CAUTION information is supplied to you for your protection and to provide you with many years of trouble free and safe operation of your product.

Read ALL instructions prior to operating reducer. Injury to personnel or reducer failure may be caused by improper installation, maintenance or operation.

### WARNING:

- Written authorization required to operate or use reducers in man lift or people moving devices.
- Check to make sure that certain applications do not exceed the allowable load capacities published in the current catalog.
- Buyer shall be solely responsible for determining the adequacy of the product for any and all uses to which Buyer shall apply the product. The application by Buyer shall not be subject to any implied warranty of fitness for a particular purpose.
- For safety, Buyer or User should provide protective guards over all shaft extensions and any moving apparatus mounted thereon. The User is responsible for checking all applicable safety codes in his area and providing suitable guards. Failure to do so may result in bodily injury and/or damage to equipment.
- Hot oil and reducers can cause severe burns. Use extreme care when removing lubrication plugs and vents.
- Make certain that the power supply is disconnected before attempting to service or remove any components. Lock out the power supply and tag it to prevent unexpected application power.
- Reducers are not to be considered fail safe or self-locking devices. If these features are required, a properly sized, independent holding device should be utilized. Reducers should not be used as a brake.
- Any brakes that are used in conjunction with a reducer must be sized or positioned in such a way so as to not subject the reducer to loads beyond the catalog rating.
- Lifting supports including eyebolts are to be used for vertically lifting the gearbox only and not other associated attachments or motors.
- Use of an oil with an EP additive on units with backstops may prevent proper operation of the backstop. Injury to personnel, damage to the reducer or other equipment may result.
- Overhung loads subject shaft bearings and shafts to stress which may cause premature bearing failure and or shaft breakage from bending fatigue, if not sized properly.

**Our company will not be responsible for any direct or indirect damages, caused by a wrong use of the products or for not observing the catalogue/web indication**

### Leggere attentamente

Le seguenti raccomandazioni sono fondamentali per la vostra protezione e per garantirvi molti anni di sicuro funzionamento del vostro prodotto senza alcun problema.

Leggere attentamente tutte le istruzioni prima di azionare il riduttore. L'inappropriata installazione, manutenzione o funzionamento del riduttore può causare incidenti al personale addetto e danni al riduttore stesso.

### ATTENZIONE!

- E' richiesta autorizzazione scritta per azionare riduttori in ascensori o dispositivi per il movimento delle persone.
- Controllare che alcune applicazioni non eccedano la massima capacità di carico ammessa pubblicata in questo catalogo.
- L'acquirente è l'unico responsabile per la determinazione dell'adeguatezza del prodotto per qualcuna o tutte le utilizzazioni che l'acquirente stesso farà del riduttore. L'applicazione dell'acquirente non potrà essere soggetta ad alcuna implicita garanzia di montaggio per uno scopo particolare.
- Per ragioni di sicurezza l'acquirente dovrà provvedere a porre protezioni adeguate su tutta la lunghezza dell'albero a tutti gli organi in movimento. L'utilizzatore è responsabile del controllo di tutti i codici di sicurezza e la predisposizione di protezioni adeguate. In assenza di tali precauzioni si possono verificare incidenti alle persone e danni agli apparati.
- Olio e riduttori bollenti possono causare gravi ustioni. Usare estrema cautela nella rimozione dei tappi e delle ventole.
- Assicurarsi che la corrente di alimentazione sia scollegata prima di riparare o rimuovere alcun componente. Chiudere l'alimentazione e contrassegnare tale operazione per evitare accensioni accidentali.
- I riduttori non devono essere considerati esenti da guasti o a bloccaggio automatico. Se sono indispensabili queste caratteristiche, deve essere utilizzato un dispositivo indipendente della dimensione adatta. I riduttori non devono essere utilizzati come freni.
- Qualsiasi freno sia utilizzato insieme al riduttore deve essere della giusta grandezza e posizionato in modo da non causare carichi eccessivi non previsti dai dati forniti nel catalogo.
- I dispositivi di sollevamento come le golfare devono essere usati solo per sollevare verticalmente il riduttore e non altri dispositivi associati o motori.
- L'utilizzo di un olio con un additivo EP su gruppi provvisti di dispositivo di arresto possono inficiare l'uso corretto del freno e provocare danni alle persone, alle cose ed al riduttore stesso nonché ad altri apparecchi.
- I Carichi sospesi assoggettano i cuscinetti della vite e la vite stessa a sollecitazioni che possono causare, se non adeguatamente dimensionati, l'usura prematura dei cuscinetti e/o la rottura della vite a causa della resistenza alla flessione.

**La nostra ditta non si ritiene responsabile per eventuali danni diretti o indiretti derivanti da un uso improprio dei prodotti e dalla mancata osservanza delle indicazioni riportate a catalogo o web..**

# Also available standard aluminum gearboxes with stainless steel output shaft and protective paint

Bevel gears

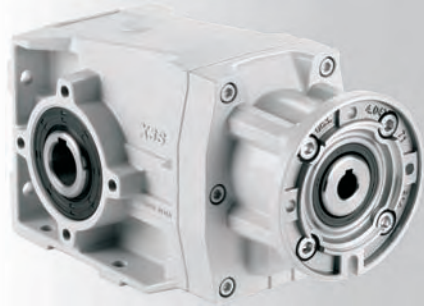

Worm gearboxes



Square gearboxes

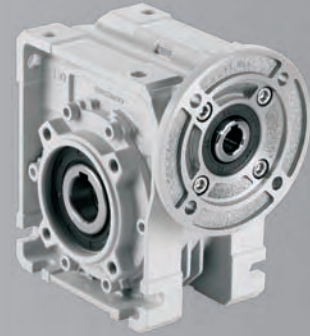

## Applications field:

Conveyors industry



Machines where water can quickly rust the hollow shaft

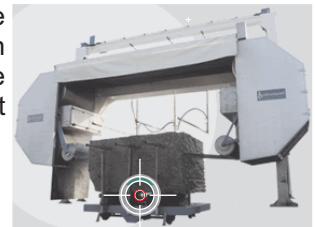

Bottling industry



Car washing



Boat / fishing industry



Chemical processing industry



Food processing industry



## HYDRO-MEC

Via della tecnica, 19  
36050 SOVIZZO (VI) ITALY

Tel. : +39 0444 551911  
Fax : +39 0444 536139

<http://www.hydromec.com>  
[hydromec@hydromec.com](mailto:hydromec@hydromec.com)



\* CT- SSM I - HM10\*