



Fenner® CHAIN DRIVES

Roller chain technology has evolved over the centuries. During this time new design features and production processes have been introduced. The new Fenner roller chain is a product of this technology.



- Extensive range of transmission roller chains and sprockets
- BS and ANSI standards
- Attachment, double pitch, conveyor, agricultural and leaf chains

Chain Drives Design Data Required

- Type of prime mover, or driving m/c
- Electric motor starting arrangement
- Rotational speed of prime mover
- Power rating of prime mover
- Type of driven machine
- Rotational speed of driven machine
- Power absorbed by driven machine
- Hours/day duty & start/stop frequency
- Both driven & driver machine shaft diameters
- Centre distance & space restraints
 - fixed centres?
 - availability of lubrication?
- Any environmental issues
 - ambient temperature
 - noise limits
 - water, oil mist etc.

CHAIN DRIVES

Page

Roller Chain Drive Selection	3
Roller Chain	7
Attachment Chain	13
Double Pitch Chain	14
Double Pitch Attachment Chain	14
Conveyor Chain	15
Agricultural Chain	16
Leaf Chain	17
Taper Lock Sprockets	20
Pilot Bore Sprockets	23
Platewheel Sprockets	27
Installation & Maintenance	30
Accessories	32

Fenner® PLUS

Power Transmission Chain

It is the detailed engineering approach and years of practical experience with chain drive applications that sets Fenner power transmission products apart and can make a real difference to your drive.

Fenner PLUS chain builds on the heritage and engineering experience of the existing Fenner product range by optimising the benefits of several performance enhancing details.

Solid Rollers: Fenner PLUS solid rollers are manufactured to achieve an extremely high surface hardness ensuring high wear resistance, great performance and a long chain life.

Shot Peening: Fenner PLUS chain plates are shot peened. This process relieves stresses that build up in manufacture and extends chain life by reducing the likelihood of fatigue failure.

Progressive Punching: All Fenner PLUS chain plates are progressively punched to give excellent hole concentricity and accuracy of both diameter and pitch. This gives a quiet and accurate mesh with the sprockets, and simple pin extraction for easy chain splitting.

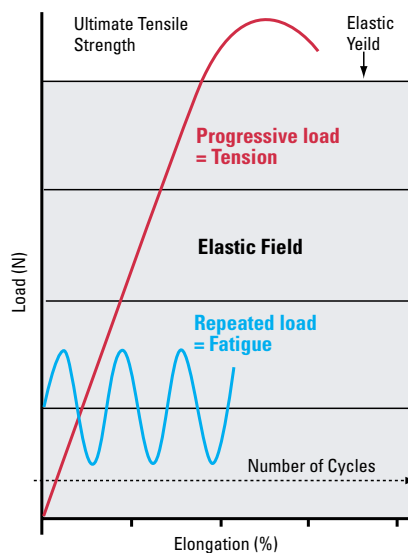

Case Hardened Pins: Fenner PLUS pins are specially case hardened to ensure resistance to abrasion from dust and debris and hence minimises chain 'stretch'.

Wax Lubrication: All Fenner PLUS chain is wax lubricated so that it can be run straight from the box. Debris cannot adhere to the dry wax finish, which helps protect against premature wear failure.

Easy Pin eXtraction: Strict tolerance and quality control procedures mean Fenner PLUS chain can be easily split by hand and assembled on-site.



Easy Pin eXtraction



SELECTION

(a) Service Factor

From Table 1, determine the service factor which is applicable to the drive.

(b) Design Power

Multiply the normal running power by the service factor. This gives the Design Power which is used as the basis for selecting the drive.

(c) Chain Pitch

Refer to Table 2 (page 4) and trace to the right along the horizontal axis to the rev/min of the faster shaft. Trace upwards along the vertical axis to the Design Power. At the point of intersection, note the recommended chain pitch or pitches if there is an overlap.

(d) Speed Ratio

Divide the speed of the faster shaft by the speed of the slower shaft to obtain the speed ratio.

(e) Sprocket Sizes

Refer to Table 4 (page 6) and select driving and driven sprockets to match the Speed Ratio found in step (d). See sprocket pitch recommendations on page 4.

(f) Power Rating

Refer to the power rating tables (page 5) for the pitch of chain chosen in step (c). Read down the left hand column to the rotational speed of the faster shaft. On this line read the power rating for the simplex chain selected. These tables are for 19 tooth sprockets, if a sprocket with a different number of teeth is used, the power rating should be multiplied by the Sprocket Factor from the table at the bottom of page 5. If the power rating figure does not equal or preferably exceed the Design Power, calculated in step (b), either select a larger pitch or a multiple strand (duplex or triplex) chain. Single strand chain offers the most economical solution, and should be used where possible. However, for limitations in space, high speed or smooth running requirements a smaller pitch, duplex or triplex drive may be considered.

(g) Chain Length

To find the Chain length in pitches, use the formula below.

$$L = \frac{2C}{P} + \frac{T+t}{2} + \frac{KP}{C}$$

L = Length of chain in pitches.

C = Centre distance in mm.

P = Pitch of chain in mm.

T = Number of teeth on large sprocket.

t = Number of teeth on small sprocket.

K = Factor from Table 3 (page 6).

The calculated number of pitches should be rounded up to an even, whole number of pitches. If the centre distance cannot be adjusted, to allow for the use of an even number of pitches, it may be necessary to use an offset or cranked link, in which case the chain power rating will need to be reduced, consult your local Authorised Distributor. Re-calculate the exact centre distance required for the adjusted number of pitches. For recommended centre distance, refer to Table 5 below.

If a jockey or tensioning sprocket is used, add an extra 2 pitches.

To obtain the chain length, multiply the number of pitches by the pitch of the chain.

$$\text{Length of chain in feet} = \frac{LP}{305}$$

TABLE 1 – SERVICE FACTORS

TYPES OF DRIVEN MACHINE	TYPES OF PRIME MOVER					
	'Soft' starts			'Heavy' starts		
	Electric motors: A.C. – Star-delta start D.C. – Shunt wound Internal combustion engines with 4 or more cylinders. All prime movers fitted with centrifugal clutches, dry or fluid couplings.			Electric motors: A.C. – Direct-on-line start D.C. – Series and compound wound. Internal combustion engines with less than 4 cylinders.		
Hours per day duty						
	10 and under	Over 10 to 16	Over 16	10 and under	Over 10 to 16	Over 16
Light Duty Agitators (uniform density), Belt conveyors (uniformly loaded).	1.0	1.1	1.2	1.1	1.2	1.3
Medium Duty Agitators and mixers (variable density). Belt conveyors (not uniformly loaded), Kilns, Laundry machinery, Lineshafts, Machine tools, Printing machinery, Sawmill and woodworking machinery, Screens (rotary).	1.1	1.2	1.3	1.2	1.3	1.4
Heavy Duty Brick machinery, Bucket elevators, Conveyors (heavy duty), Hoists, Quarry plant, Rubber machinery, Screens (vibrating), Textile machinery.	1.3	1.4	1.5	1.5	1.6	1.7

EXAMPLE

Select a chain drive to transmit 1.5 kW from a gearbox running at 80 rev/min and driven by a direct-on-line electric motor, to a uniformly loaded conveyor drive shaft which is required to run at approximately 40 rev/min for 12 hours per day. Gearbox output shaft is 35mm and the conveyor headshaft is 65mm diameter.

(a) Service Factor

From Table 1 the Service Factor is 1.2.

(b) Design Power

= 1.5 x 1.2 = 1.8 kW.

(c) Chain Pitch

By referring to Table 2 (page 4), the intersection of design power and the rev/min of the faster shaft indicates a 16B 1" pitch chain.

(d) Speed Ratio

$$\frac{80}{40} = 2:1$$

(e) Sprocket Size

From Table 4 (page 6) sprockets of 19 and 38 teeth give a ratio of 2 : 1.

(f) Power Rating

The power ratings for 16B chain are given on page 5. The required power rating from step (b) is 1.8 kW. For a 19T driver sprocket, running at 80 rev/minute, the power rating for 16B-1 simplex chain is 3.79 kW. As this exceeds the required

design power the selection is satisfactory.

If space limitations demand smaller sprocket dimensions, alternative selections would be: use 12B-2 duplex chain which has a power rating of 2.11 kW at 80 rev/min or 15T driving to 30T on 16 B-1 1" simplex chain - power rating 0.8 x 3.79 = 3.03 kW

g) Chain Length

Recommended centre distance for 16B-1 chain is 1000 mm (Table 5 below).

Therefore the chain length as per selection step (g) (chain length) is 108 pitches including a connecting link.

Drive Specification

108 pitches or 9 feet of Fenner 16B-1 chain 81-19 Driver Sprocket with a 2517 x 35mm bore 81-38 Driven Sprocket with a 3020 x 65mm bore

Alternative selection

Recommended centre distance for 12B-2 chain is 900 mm (Table 5 below).

Therefore the chain length as per selection step (g) (chain length) is 124 pitches including a connecting link.

Alternative Drive Specification

124 pitches or 7.75 feet of Fenner 12B-2 chain 62-19 Driver Sprocket with a 2012 x 35mm bore 62-38 Driven Sprocket with a 3020 x 65mm bore.

TABLE 5 - RECOMMENDED CENTRE DISTANCE

Chain Pitch	Inches	3/8"	1/2"	5/8"	3/4"	1"	1.1/4"	1.1/2"	1.3/4"	2"
	mm	9.525	12.7	15.875	19.05	25.4	31.75	38.1	44.45	50.8
Centre Distance	mm	450	600	750	900	1000	1200	1350	1500	1700

TABLE 2 - BRITISH STANDARD CHAIN

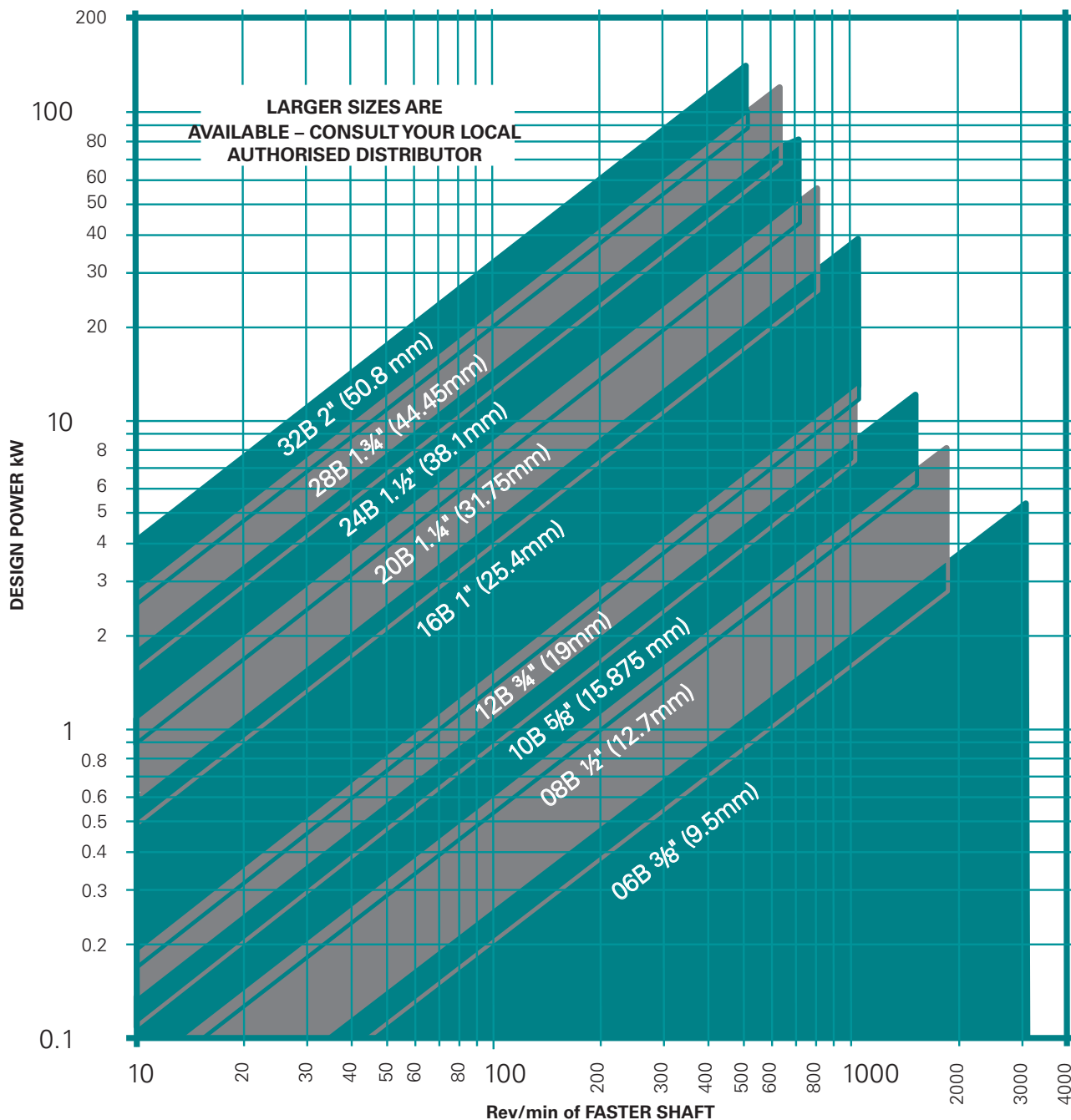

GENERAL RECOMMENDATIONS ON SPROCKET SIZES

19 teeth and above —

Sprockets running at medium to maximum speeds on normal applications (see power ratings for speeds on page 5).

17 teeth —

Permissible to use this sprocket on very small pitches ie, 8mm and 3/8". Refer to section above, but should be restricted to slow speed drives (see power ratings for speeds on page 5).

15 teeth or less —

Should be avoided unless shaft speed is below 100 revs/min.

23 teeth and above —

Recommended for impulse applications.

When ratios are low, the use of sprockets with high numbers of teeth minimises joint articulation, chain pull and bearing loads. If a small number of teeth are used on high speed, high load applications, hardening of teeth should be considered. Ratios over 7:1 are not recommended for single strand drives. In all drives where ratios exceed 5:1 the designer should consider using compound drives for maximum service life.

On drives where ratios exceed 3:1 the shaft centre distance should not be less than the sum of the sprocket pitch circle diameters.

For drives with vertical shafting always use multi-strand chains.

Roller Chain Drive Selection



POWER RATINGS (KW) FOR BRITISH STANDARD CHAIN BASED ON 19 TOOTH DRIVER SPROCKETS

06B 3/8" (9.5mm) PITCH

Rev/min faster Shaft	19 Tooth			Type of Lubrication
	Simplex	Duplex	Triplex	
20	0.06	0.10	0.15	1
40	0.11	0.19	0.27	
60	0.16	0.27	0.40	
80	0.20	0.34	0.50	
100	0.25	0.43	0.62	
200	0.46	0.78	1.15	
400	0.86	1.46	2.15	2
600	1.24	2.11	3.10	
800	1.60	2.72	4.00	
1000	1.96	3.33	4.90	
1200	2.31	3.93	5.77	
1400	2.65	4.51	6.62	
1600	2.99	5.10	7.47	3
1800	3.33	5.66	8.32	
2000	3.66	6.22	9.15	
2200	3.99	6.78	9.97	
2400	4.31	7.33	10.77	
2600	4.63	7.87	11.57	
2800	4.95	8.42	12.37	
3000	5.27	8.96	13.17	

08B 1/2" (12.7mm) PITCH

Rev/min faster Shaft	19 Tooth			Type of Lubrication
	Simplex	Duplex	Triplex	
10	0.07	0.12	0.17	1
20	0.14	0.24	0.35	
30	0.20	0.34	0.50	
40	0.26	0.44	0.65	
50	0.31	0.53	0.77	
60	0.37	0.63	0.92	
70	0.42	0.71	1.05	
80	0.48	0.82	1.20	
100	0.58	0.99	1.45	
200	1.09	1.85	2.72	
300	1.57	2.67	3.92	2
400	2.03	3.45	5.07	
500	2.48	4.22	6.20	
600	2.92	4.96	7.30	
800	3.78	6.43	9.45	
900	4.63	7.87	11.57	
1200	5.45	7.27	13.62	
1400	6.26	10.64	15.65	
1600	7.06	12.00	17.65	
1800	7.85	13.35	19.62	

10B 5/8" (15.875 mm) PITCH

Rev/min faster Shaft	19 Tooth			Type of Lubrication
	Simplex	Duplex	Triplex	
10	0.13	0.22	0.33	1
20	0.25	0.43	0.63	
30	0.36	0.61	0.89	
40	0.46	0.78	1.15	
50	0.57	0.96	1.40	
60	0.67	1.13	1.66	
70	0.76	1.29	1.90	
80	0.86	1.47	2.15	
100	1.07	1.78	2.62	
200	1.96	3.33	4.90	
300	2.88	4.80	7.05	2
400	3.65	6.21	9.13	
500	4.55	7.60	11.17	
600	5.25	8.94	13.15	
800	6.81	11.58	17.03	
900	7.76	13.19	19.40	
1000	8.33	14.16	23.33	
1200	9.81	16.68	24.42	
1500	12.01	20.42	29.90	

12B 3/4" (19mm) PITCH

Rev/min faster Shaft	19 Tooth			Type of Lubrication
	Simplex	Duplex	Triplex	
10	0.19	0.32	0.48	1
20	0.36	0.61	0.90	
30	0.51	0.87	1.28	
40	0.66	1.12	1.65	
50	0.84	1.43	2.10	
60	0.96	1.63	2.40	
70	1.10	1.87	2.75	
80	1.24	2.11	3.10	
90	1.38	2.35	3.45	
100	1.55	2.64	3.88	
200	2.90	4.93	7.25	2
300	4.07	6.92	10.18	
400	5.27	8.96	13.18	
500	6.62	11.25	16.55	
600	7.60	12.92	19.00	
700	8.95	15.22	22.38	
800	9.84	16.73	24.60	
900	11.26	19.14	28.15	
1000	12.03	20.45	35.08	
1200	14.55	24.74	36.38	

16B 1" (25.4mm) PITCH

Rev/min faster Shaft	19 Tooth			Type of Lubrication
	Simplex	Duplex	Triplex	
5	0.31	0.53	0.78	1
10	0.58	0.99	1.45	
20	1.09	1.85	2.73	
30	1.57	2.67	3.93	
40	2.03	3.45	5.08	
50	2.48	4.22	6.20	
60	2.92	4.96	7.30	
70	3.36	5.71	8.40	
80	3.79	6.44	9.48	
90	4.21	7.16	10.53	
100	4.63	7.87	11.58	
200	8.64	14.69	21.60	2
300	12.45	21.17	31.13	
400	16.13	27.42	40.33	
500	19.72	33.52	49.30	
600	23.23	39.49	58.08	
700	26.69	45.37	66.73	
800	30.10	51.17	75.25	
900	33.46	56.88	83.65	
1000	36.79	62.54	91.98	

20B 1 1/4" (31.75mm) PITCH

Rev/min faster Shaft	19 Tooth			Type of Lubrication
	Simplex	Duplex	Triplex	
10	1.02	1.73	2.55	1
25	2.50	4.25	6.25	
50	4.65	7.90	11.63	
100	8.65	14.70	21.63	
150	12.40	21.08	31.00	
200	16.20	27.54	40.50	2
250	19.73	33.54	49.33	
300	23.27	39.56	58.18	
350	26.70	45.40	66.75	
400	30.20	51.34	75.50	
450	33.50	56.95	83.75	3
500	36.92	62.76	92.30	
600	43.50	73.95	108.75	
700	49.95	84.91	124.88	
800	55.50	94.35	138.75	

24B 1 1/2" (38.1mm) PITCH

Rev/min faster Shaft	19 Tooth			Type of Lubrication
	Simplex	Duplex	Triplex	
10	2.22	3.77	5.55	1
25	5.03	8.55	12.58	
50	9.40	15.98	23.50	
100	17.50	29.75	43.75	2
150	25.30	43.01	63.25	
200	32.70	55.59	81.75	
300	47.20	80.24	118.00	
400	61.60	104.72	154.00	
500	74.60	126.82	186.50	3
600	88.00	149.60	220.00	
700	94.00	159.80	235.00	

28B 1 3/4" (44.45mm) PITCH

Rev/min faster Shaft	19 Tooth			Type of Lubrication
	Simplex	Duplex	Triplex	
10	3.44	5.85	8.60	1
25	7.83	13.31	19.58	
50	14.32	24.34	35.80	
100	27.30	46.41	68.25	2
150	39.39	66.96	98.48	
200	51.10	86.87	127.75	
250	62.66	106.52	156.65	
300	73.18	124.41	182.95	
350	84.30	143.31	210.75	3
400	94.70	160.99	236.75	
450	105.90	180.03	264.75	
500	116.40	197.88	291.00	
600	133.50	226.95	333.75	

32B 2" (50.8mm) PITCH

Rev/min faster Shaft	19 Tooth			Type of Lubrication
	Simplex	Duplex	Triplex	
10	4.54	7.72	11.35	1
25	10.44	17.75	26.10	
50	19.40	32.98	48.50	
100	36.10	61.37	90.25	2
150	51.80	88.06	129.50	
200	67.30	114.41	168.25	
250	82.10	139.57	205.25	
300	97.00	164.90	242.50	
350	112.00	190.40	280.00	3
400	126.00	214.20	315.00	
500	154.00	261.80	385.00	

SPROCKET FACTOR

N° Teeth	11	13	15	17	19	21	23	25	27
Factor	0.5	0.65	0.8	0.9	1.0	1.1	1.2	1.3	1.4

For driver sprockets other than 19 tooth, multiply the power rating by the Sprocket Factor (above) to calculate the actual power rating.

For detail of lubrication types see page 30.

Roller Chain Drive Selection

TABLE 3 – K FACTOR

T-t	K	T-t	K	T-t	K	T-t	K	T-t	K	T-t	K	T-t	K	T-t	K	T-t	K
1	0	11	3	21	11	31	24	41	43	51	66	61	94	71	128	81	166
2	0	12	4	22	12	32	26	42	45	52	68	62	97	72	131	82	170
3	0	13	4	23	13	33	28	43	47	53	71	63	101	73	135	83	175
4	0	14	5	24	15	34	29	44	49	54	74	64	104	74	139	84	179
5	1	15	6	25	16	35	31	45	51	55	77	65	107	75	142	85	183
6	1	16	6	26	17	36	33	46	54	56	79	66	110	76	146	86	187
7	1	17	7	27	18	37	35	47	56	57	82	67	114	77	150	87	192
8	2	18	8	28	20	38	37	48	58	58	85	68	117	78	154	88	196
9	2	19	9	29	21	39	39	49	61	59	88	69	121	79	158	89	201
10	3	20	10	30	23	40	41	50	63	60	91	70	124	80	162	90	205

TABLE 4 – SPEED RATIOS

Number of teeth – Driving Sprocket																			
	10	11	12	13	14	15	16	17	18	19	20	21	22	23	24	25	27	30	
Number of teeth – Driven Sprocket	10	1.00																	
	11	1.10	1.00																
	12	1.20	1.09	1.00															
	13	1.30	1.18	1.08	1.00														
	14	1.40	1.27	1.17	1.08	1.00													
	15	1.50	1.36	1.25	1.15	1.07	1.00												
	16	1.60	1.45	1.33	1.23	1.14	1.07	1.00											
	17	1.70	1.55	1.42	1.31	1.21	1.13	1.06	1.00										
	18	1.80	1.64	1.50	1.38	1.29	1.20	1.13	1.06	1.00									
	19	1.90	1.73	1.58	1.46	1.36	1.27	1.19	1.12	1.06	1.00								
	20	2.00	1.82	1.67	1.54	1.43	1.33	1.25	1.18	1.11	1.05	1.00							
	21	2.10	1.91	1.75	1.62	1.50	1.40	1.31	1.24	1.17	1.11	1.05	1.00						
	22	2.20	2.00	1.83	1.69	1.57	1.47	1.38	1.29	1.22	1.16	1.10	1.05	1.00					
	23	2.30	2.09	1.92	1.77	1.64	1.53	1.44	1.35	1.28	1.21	1.15	1.10	1.05	1.00				
	24	2.40	2.18	2.00	1.85	1.71	1.60	1.50	1.41	1.33	1.26	1.20	1.14	1.09	1.04	1.00			
	25	2.50	2.27	2.08	1.92	1.79	1.67	1.56	1.47	1.39	1.32	1.25	1.19	1.14	1.09	1.04	1.00		
	26	2.60	2.36	2.17	2.00	1.86	1.73	1.63	1.53	1.44	1.37	1.30	1.24	1.18	1.13	1.08	1.04		
	27	2.70	2.45	2.25	2.08	1.93	1.80	1.69	1.59	1.50	1.42	1.35	1.29	1.23	1.17	1.13	1.08	1.00	
	28	2.80	2.54	2.33	2.15	2.00	1.87	1.75	1.65	1.56	1.47	1.40	1.33	1.27	1.22	1.17	1.12	1.04	
	29	2.90	2.64	2.42	2.23	2.07	1.93	1.81	1.71	1.61	1.53	1.45	1.38	1.32	1.26	1.21	1.16	1.07	
30	3.00	2.73	2.50	2.31	2.14	2.00	1.88	1.76	1.67	1.58	1.50	1.43	1.36	1.30	1.25	1.20	1.11	1.00	
38	3.80	3.45	3.17	2.92	2.71	2.53	2.38	2.24	2.11	2.00	1.90	1.81	1.73	1.65	1.58	1.52	1.41	1.27	
57	5.70	5.18	4.75	4.38	4.07	3.80	3.56	3.35	3.17	3.00	2.85	2.71	2.59	2.48	2.38	2.28	2.11	1.90	
76	7.60	6.91	6.33	5.85	5.43	5.07	4.75	4.47	4.22	4.00	3.80	3.62	3.45	3.30	3.17	3.04	2.81	2.53	
95	9.50	8.64	7.92	7.31	6.79	6.33	5.94	5.59	5.28	5.00	4.75	4.52	4.32	4.13	3.96	3.80	3.52	3.17	

Ratios in BOLD type indicate ratios generally available in Taper Lock®

CHAIN LENGTH CONVERSION DATA

Chain Pitch (ins)	Pitches/ft	Pitches/Metre	Chain Pitch (ins)	Pitches/ft	Pitches/Metre
6mm	50.8	166.67	1"	12	39.37
8mm	38.1	125.00	1¼"	9.6	31.49
1¼"	48	157.48	1½"	8	26.25
3/8"	32	104.99	1¾"	6.86	22.50
1/2"	24	78.74	2"	6	19.68
5/8"	19.2	62.99			
3/4"	16	52.49			



ROLLER CHAIN LINKS

CONN. LINK	CONN. LINK	RIVET PIN LINK	DOUBLE OFF-SET LINK	INNER LINK	OFFSET LINK
Spring Clip Type	Cotter Type	Rivet-on Type			
BRITISH STANDARD (BS)					
04B		04B	04B	04B	
05B		05B	05B	05B	
06B	06B	06B	06B	06B	06B
08B	08B	08B	08B	08B	08B
10B	10B	10B	10B	10B	10B
12B	12B	12B	12B	12B	12B
16B	16B	16B	16B	16B	16B
	20B	20B		20B	20B
	24B	24B		24B	24B
	28B	28B		28B	28B
	32B	32B		32B	32B
AMERICAN STANDARD (ASA)					
25		25	25	25	
35	35	35	35	35	35
40	40	40	40	40	40
41	41	41	41	41	41
50	50	50	50	50	50
60	60	60	60	60	60
80	80	80	80	80	80
	100	100		100	100
	120	120		120	120
	140	140		140	140
	160	160		180	160
ASA HEAVY DUTY					
40H		40H	40H	40H	
50H	50H	50H	50H	50H	50H
60H	60H	60H	60H	60H	60H
80H	80H	80H	80H	80H	80H
	100H	100H	100H	100H	100H
	120H	120H	120H	120H	120H
DOUBLE PITCH					
A2040	A2040	A2040		A2040	A2040
A2050	A2050	A2050		A2050	A2050
A2060	A2060	A2060		A2060	A2060
C2040	C2040	C2040		C2040	C2040
C2050	C2050	C2050		C2050	C2050
C2060/H	C2060/H	C2060/H		C2060/H	C2060/H
	C2080/H	C2080/H		C2080/H	
	C2100/H	C2100/H		C2100/H	
	C2120/H	C2120/H		C2120/H	
C2042	C2042	C2042		C2042	C2042
C2052	C2052	C2052		C2052	C2052
C2062/H	C2062/H	C2062/H		C2062/H	C2062/H
	C2082/H	C2082/H		C2082/H	
	C2102/H	C2102/H		C2102/H	
	C2122/H	C2122/H		C2122/H	

SPRING CLIP CONNECTING LINK

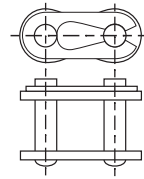

COTTER CONNECTING LINK

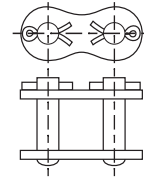

RIVET PIN LINK

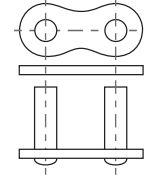

INNER LINK

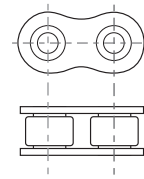

OFFSET LINK

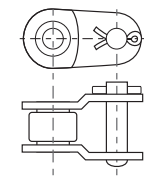

DOUBLE OFFSET LINK

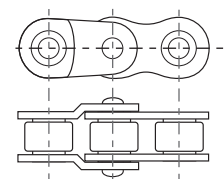

ENDLESS - EVEN NO. OF LINKS



Odd number of links, with inner at each end and 1 standard connecting link.

ENDLESS - ODD NO. OF LINKS

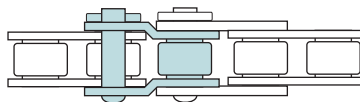

Even number of links, with inner at one end and outer at other end plus 1 offset link.

ENDLESS - ODD NO. OF LINKS

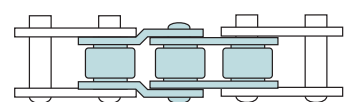

Odd number of links, with outer at each end plus 1 double offset link.

BRITISH STANDARD ROLLER CHAINS
BS 228, ISO R606, DIN 8187

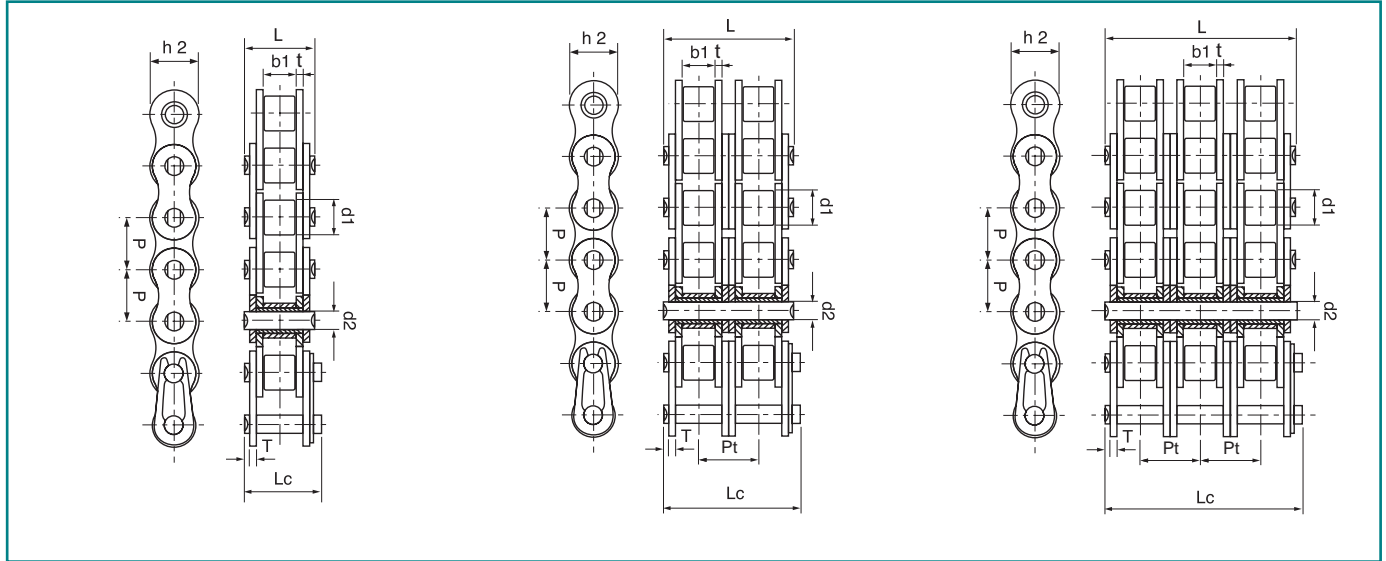

Product Code		Chain No	ISO	Pitch Diameter	Roller Between Inner Plates	Width Diameter	PinLength		Inner Plate Depth	Plate Thickness	Transverse Pitch	Fenner PLUS Min Tensile Strength	Fenner Standard Min Tensile Strength	Weight per foot
Fenner Standard	Fenner PLUS						L max mm	Lc max mm						
			P mm	d1 max mm	b1 min mm	d2 max mm	L max mm	Lc max mm	h2 max mm	t/T max mm	Pt mm	Q min kN	Q0 kN	q kg/ft
SIMPLEX														
028H0110	-	04B-1	6.000	4.00	2.80	1.85	6.80	7.80	5.00	0.60	-	-	3.00	0.033
028J0110	-	05B-1	8.000	5.00	3.00	2.31	8.20	8.90	7.10	0.80	-	-	5.00	0.060
028A0110	028A0111	#06B-1	9.525	6.35	5.72	3.27	13.50	14.10	8.23	1.30	-	9.00	9.00	0.122
028B0110	028B0111	08B-1	12.700	8.51	7.75	4.45	16.60	18.20	11.80	1.60	-	18.20	18.00	0.210
028C0110	028C0111	10B-1	15.875	10.16	9.65	5.08	19.00	20.90	13.70	1.70	-	23.00	22.40	0.259
028D0110	028D0111	12B-1	19.050	12.07	11.68	5.72	22.30	24.20	16.20	1.85	-	30.50	29.00	0.357
028E0110	028E0111	16B-1	25.400	15.88	17.02	8.28	35.10	37.40	20.80	4.15/3.1	-	66.00	60.00	0.811
028F0110	028F0111	20B-1	31.750	19.05	19.56	10.19	40.50	45.00	25.40	4.5/3.5	-	105.00	95.00	1.134
028G0110	028G0111	24B-1	38.100	25.40	25.40	14.63	53.10	57.80	32.30	6.0/4.8	-	180.00	160.00	2.149
028T0110	028T0111	28B-1	44.450	27.94	30.95	15.90	65.10	69.50	37.00	7.5/6.0	-	235.00	200.00	2.731
028U0110	028U0111	32B-1	50.800	29.21	30.99	17.81	63.60	71.00	42.30	7.0/6.0	-	270.00	250.00	3.048
028V0110	028V0111	40B-1	63.500	39.37	38.10	22.89	79.00	89.20	52.80	8.5/8.0	-	365.00	355.00	4.938
028Z0110	028Z0111	48B-1	76.200	48.26	45.72	29.24	99.10	107.00	64.20	12/10	-	600.00	560.00	7.598
DUPLEX														
028J0210	-	05B-2	8.000	5.00	3.00	2.31	13.90	14.50	7.10	0.80	5.64	-	7.80	0.100
028A0210	028A0211	#06B-2	9.525	6.35	5.72	3.27	23.80	24.40	8.23	1.30	10.24	17.60	16.90	0.226
028B0210	028B0211	08B-2	12.700	8.51	7.75	4.45	30.60	32.20	11.80	1.60	13.92	36.40	32.00	0.411
028C0210	028C0211	10B-2	15.875	10.16	9.65	5.08	35.75	37.50	13.70	1.70	16.59	46.00	44.50	0.506
028D0210	028D0211	12B-2	19.050	12.07	11.68	5.72	41.80	43.60	16.20	1.85	19.46	61.00	57.80	0.707
028E0210	028E0211	16B-2	25.400	15.88	17.02	8.28	68.00	69.30	20.80	4.15/3.1	31.88	132.00	106.00	1.609
028F0210	028F0211	20B-2	31.750	19.05	19.56	10.19	77.00	81.50	25.40	4.5/3.5	36.45	210.00	170.00	2.243
028G0210	028G0211	24B-2	38.100	25.40	25.40	14.63	101.80	106.20	33.40	6.0/4.8	48.36	360.00	280.00	4.221
028T0210	028T0211	28B-2	44.450	27.94	30.95	15.90	124.60	129.10	37.00	7.5/6.0	59.56	470.00	360.00	5.730
028U0210	028U0211	32B-2	50.800	29.21	30.99	17.81	124.60	129.60	42.30	7.0/6.0	58.55	540.00	450.00	6.035
028V0210	028V0211	40B-2	63.500	39.37	38.10	22.89	152.00	161.50	52.80	8.5/8.0	72.29	730.00	630.00	9.778
028Z0210	028Z0211	48B-2	76.200	48.26	47.70	29.22	190.40	198.20	64.20	12/10	91.21	1200.00	1000.00	15.087
TRIPLEX														
028A0310	028A0311	#06B-3	9.525	6.35	5.72	3.27	34.00	34.60	8.23	1.30	10.24	26.50	24.90	0.335
028B0310	028B0311	08B-3	12.700	8.51	7.75	4.45	44.60	46.10	11.80	1.60	13.92	54.60	47.50	0.616
028C0310	028C0311	10B-3	15.875	10.16	9.65	5.08	52.30	54.10	13.70	1.70	16.59	69.00	66.70	0.795
028D0310	028D0311	12B-3	19.050	12.07	11.68	5.72	61.40	63.10	16.20	1.85	19.46	91.50	86.70	1.975
028E0310	028E0311	16B-3	25.400	15.88	17.02	8.28	99.90	101.20	20.80	4.15/3.1	31.88	198.00	160.00	2.396
028F0310	028F0311	20B-3	31.750	19.05	19.56	10.19	113.50	117.90	25.40	4.5/3.5	36.45	315.00	250.00	3.353
028G0310	028G0311	24B-3	38.100	25.40	25.40	14.63	150.20	154.60	33.40	6.0/4.8	48.36	540.00	425.00	6.190
028T0310	028T0311	28B-3	44.450	27.94	30.95	15.90	184.60	188.70	37.00	7.5/6.0	59.56	705.00	530.00	8.534
028U0310	028U0311	32B-3	50.800	29.21	30.99	17.81	184.60	188.20	42.30	7.0/6.0	58.55	810.00	670.00	9.022
028V0310	028V0311	40B-3	63.500	39.37	38.10	22.89	224.60	233.80	52.80	8.5/8.0	72.29	1095.00	950.00	14.617
028Z0310	028Z0311	48B-3	76.200	48.26	47.70	29.22	281.60	289.40	64.20	12/10	91.21	1800.00	1500.00	24.444

For weight in metres multiply by 3.281

Straight side plates.

Chain is sold in units of feet

All Fenner Standard and Fenner PLUS chains are equivalent to or exceed ISO 606 minimum tensile strength

or metres, depending on

The above dimensions are for Fenner PLUS chain, some non-functional dimensions may differ slightly for Fenner Standard Chain

geographical market



AMERICAN STANDARD ROLLER CHAINS
ANSI B29.1, ISO R606, DIN 8188

ANSI standard chain is dimensionally similar to BS chain but with generally thicker plates resulting in a narrower b1 dimension between inner plates. The pitching between strands of duplex and triplex chain, dimension Pt may also vary from BS chain.

Care should be taken to ensure that correct sprockets are used with ANSI chain.

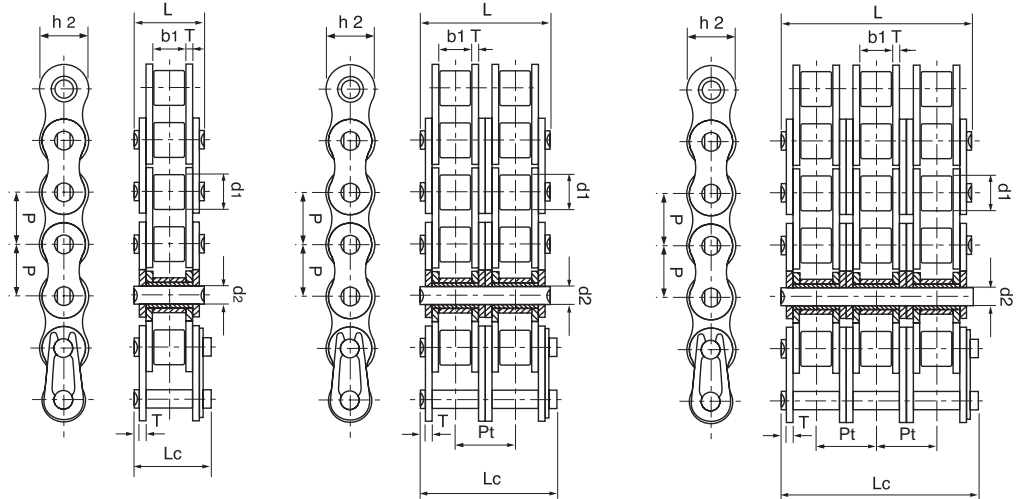

Product Code		ANSI Chain No	ISO Chain	Pitch	Roller Dia.	Width Between Inner Plates	Pin Dia.	Pin Length			Inner Plate Depth	Plate Thickness	Transverse Pitch	Fenner PLUS Min Tensile Strength	Fenner Standard Min Tensile Strength	Weight per foot
Fenner Standard	Fenner PLUS							L max mm	Lc max mm	h2 max mm						
				P mm	d1 max mm	b1 min mm	d2 max mm	L max mm	Lc max mm	h2 max mm	t/T max mm	Pt mm	Q min kN	Qo kN	q kg/ft	
SIMPLEX																
028K0110	-	•35	•06C-1	9.525	5.080	4.77	3.58	12.40	13.17	9.00	1.30	-	-	7.90	0.045	
028L0110	028L0111	40	08A-1	12.700	7.930	7.85	3.98	16.30	17.80	11.50	1.50	-	16.50	14.10	0.180	
028M0110	-	41	08S-1	12.700	7.770	6.25	3.58	13.75	15.00	9.91	1.30	-	-	6.67	0.125	
028N0110	028N0111	50	10A-1	15.875	10.150	9.55	5.09	20.45	22.20	13.70	2.03	-	27.00	22.20	0.304	
028P0110	028P0111	60	12A-1	19.050	11.910	12.65	5.96	25.40	27.70	16.20	2.42	-	38.00	31.80	0.414	
028Q0110	028Q0111	80	16A-1	25.400	15.880	15.88	7.94	32.80	35.00	20.80	3.25	-	62.00	56.70	0.786	
028R0110	028R0111	100	20A-1	31.750	19.050	19.05	9.53	39.60	44.70	25.40	4.00	-	99.00	88.50	1.183	
028S0110	028S0111	120	24A-1	38.100	22.220	25.40	11.10	49.60	54.30	35.20	4.80	-	140.00	127.00	1.695	
028V0110	028V0111	140	28A-1	44.450	25.400	25.40	12.70	53.50	59.00	42.00	5.60	-	178.00	172.40	2.268	
028X0110	028X0111	160	32A-1	50.800	28.580	31.75	14.27	64.00	69.60	48.20	6.40	-	228.00	226.80	3.060	
028Y0110	028Y0111	200	40A-1	63.500	39.670	38.10	19.85	77.90	87.20	58.00	8.00	-	380.00	353.80	5.090	
028Z0110	028Z0111	240	48A-1	76.200	47.630	47.60	23.80	94.50	103.00	71.80	9.50	-	700.00	510.30	7.220	
DUPLEX																
028K0210	-	•35-2	•06C-2	9.525	5.080	4.77	3.58	22.50	23.30	9.00	1.30	10.13	-	15.80	0.085	
028L0210	028L0211	40-2	08A-2	12.700	7.930	7.85	3.98	30.80	32.20	11.50	1.50	14.38	33.00	28.20	0.366	
028N0210	028N0211	50-2	10A-2	15.875	10.150	9.55	5.09	38.90	40.40	13.70	2.03	18.11	54.00	44.40	0.609	
028P0210	028P0211	60-2	12A-2	19.050	11.910	12.65	5.96	48.30	50.50	16.20	2.42	22.78	76.00	63.60	0.829	
028Q0210	028Q0211	80-2	16A-2	25.400	15.880	15.87	7.94	62.30	64.30	20.80	3.25	29.29	124.00	113.40	1.554	
028R0210	028R0211	100-2	20A-2	31.750	19.050	19.05	9.53	75.50	80.50	25.40	4.00	35.76	198.00	177.00	2.347	
028S0210	028S0211	120-2	24A-2	38.100	22.220	25.40	11.10	95.30	99.70	35.20	4.80	45.44	280.00	254.00	3.340	
028W0210	028W0211	140-2	28A-2	44.450	25.400	25.40	12.70	102.60	107.90	42.00	5.60	48.87	356.00	344.80	4.499	
028X0210	028X0211	160-2	32A-2	50.800	28.580	31.75	14.27	123.30	144.40	48.20	6.40	58.55	456.00	453.60	6.065	
028Y0210	028Y0211	200-2	40A-2	63.500	39.670	38.10	19.85	150.20	158.80	58.00	8.00	71.55	760.00	707.60	10.119	
028Z0210	028Z0211	240-2	48A-2	76.200	47.600	47.60	23.80	182.20	190.80	71.80	9.50	87.83	1400.00	1020.60	14.400	
TRIPLEX																
028K0310	-	•35-3	•06C-3	9.525	5.08	4.77	3.58	32.70	33.50	9.00	1.30	10.13	-	23.70	0.134	
028L03010	028L0311	40-3	08A-3	12.700	7.93	7.85	3.98	45.30	46.60	11.50	1.50	14.38	49.50	42.30	0.550	
028N0310	028N0311	50-3	10A-3	15.875	10.15	9.55	5.09	57.00	58.50	13.70	2.03	18.11	81.00	66.60	0.908	
028P3010	028P3011	60-3	12A-3	19.050	11.91	12.65	5.96	71.10	73.30	16.20	2.42	22.78	114.00	95.40	1.243	
028Q3010	028Q3011	80-3	16A-3	25.400	15.88	15.88	7.94	91.80	93.60	20.80	3.25	29.29	186.00	170.10	2.340	
028R3010	028R3011	100-3	20A-3	31.750	19.05	19.05	9.53	112.10	116.30	25.40	4.00	35.76	297.00	265.50	3.511	
028S3010	028S3011	120-3	24A-3	38.100	22.22	25.40	11.10	140.90	145.20	35.20	4.80	45.44	420.00	381.00	5.011	
028W0310	028W0311	140-3	28A-3	44.450	25.4	25.40	12.70	152.40	156.80	42.00	5.60	48.87	534.00	517.20	6.730	
028X0310	028X0311	160-3	32A-3	50.800	28.58	31.75	14.27	182.00	182.00	48.20	6.40	58.55	684.00	680.40	9.070	
028Y0310	028Y0310	200-3	40A-3	63.500	39.67	38.10	19.85	222.20	230.40	58.00	8.00	71.55	1140.00	1061.40	15.148	
028Z0310	028Z0311	240-3	48A-3	76.200	47.6	47.60	23.80	270.00	278.60	71.80	9.50	87.83	2100.00	1530.90	21.49	

For weight in metres multiply by 3.281

• Bushing chain, d1 indicates the external diameter of the bushing.
Cottered chain can be supplied for all chains of 19.05 mm pitch and above.

Chain is sold in units of feet or metres, depending on geographical market

All Fenner Standard and Fenner PLUS chains are equivalent to or exceed ISO 606 minimum tensile strength

The above dimensions are for Fenner PLUS chain, some non-functional dimensions may differ slightly for Fenner Standard Chain

**BRITISH STANDARD FENNER PLUS LUBRICATION FREE ROLLER CHAIN
BS 228, ISO R606, DIN 8187**

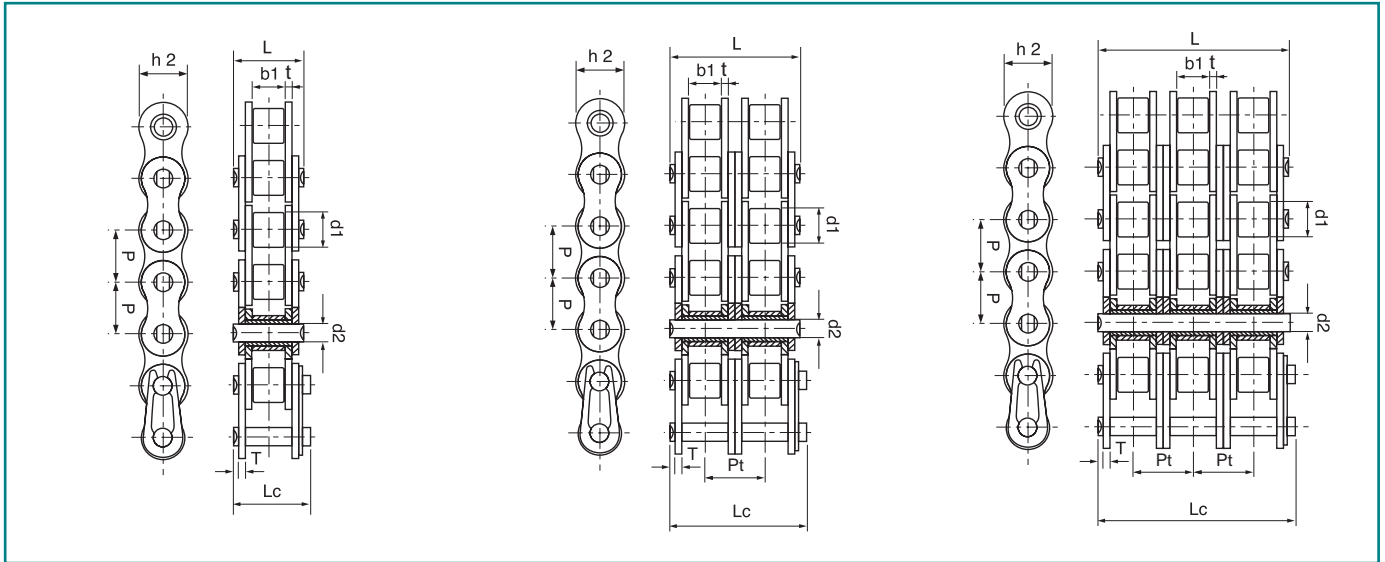

Product Code	ISO Chain No	Pitch	Roller Diameter	Width Between Inner Plates	Pin Diameter	Pin Length		Inner Plate Depth	Plate Thickness	Transverse Pitch	Fenner + Minimum Tensile Strength	ISO 606 Minimum Tensile Strength	Weight per Foot
						L max mm	Lc max mm						
SIMPLEX													
028B0114	08B-1	12.700	8.51	7.75	4.45	16.60	18.20	11.80	1.6		17.80	17.8	0.210
028C0114	10B-1	15.875	10.16	9.65	5.08	19.00	20.90	13.70	1.7		22.20	22.2	0.259
028D0114	12B-1	19.050	12.07	11.68	5.72	22.30	24.20	16.20	1.85		28.90	28.9	0.357
028E0114	16B-1	25.400	15.88	17.02	8.28	35.10	37.40	20.80	4.15/3.1		60.00	60.0	0.811
DUPLEX													
028B0214	08B-2	12.700	8.51	7.75	4.45	30.60	32.20	11.80	1.6	13.92	31.10	31.10	0.411
028C0214	10B-2	15.875	10.16	9.65	5.08	35.75	37.50	13.70	1.7	16.59	44.50	44.50	0.506
028D0214	12B-2	19.050	12.07	11.68	5.72	41.80	43.60	16.20	1.85	19.46	57.80	57.80	0.707
028E0214	16B-2	25.400	15.88	17.02	8.28	68.00	69.30	20.80	4.15/3.1	31.88	106.00	106.00	1.609
TRIPLEX													
028B0314	08B-3	12.700	8.51	7.75	4.45	44.60	46.10	11.80	1.6	13.92	44.50	44.5	0.616
028C0314	10B-3	15.875	10.16	9.65	5.08	52.30	54.10	13.70	1.7	16.59	66.70	66.7	0.795
028D0314	12B-3	19.050	12.07	11.68	5.72	61.40	63.10	16.20	1.85	19.46	86.70	86.70	1.975
028E0314	16B-3	25.400	15.88	17.02	8.28	99.90	101.20	20.80	4.15/3.1	31.88	160.00	160.00	2.396

Chain is sold in units of feet or metres, depending on geographical market



AMERICAN STANDARD ROLLER CHAINS

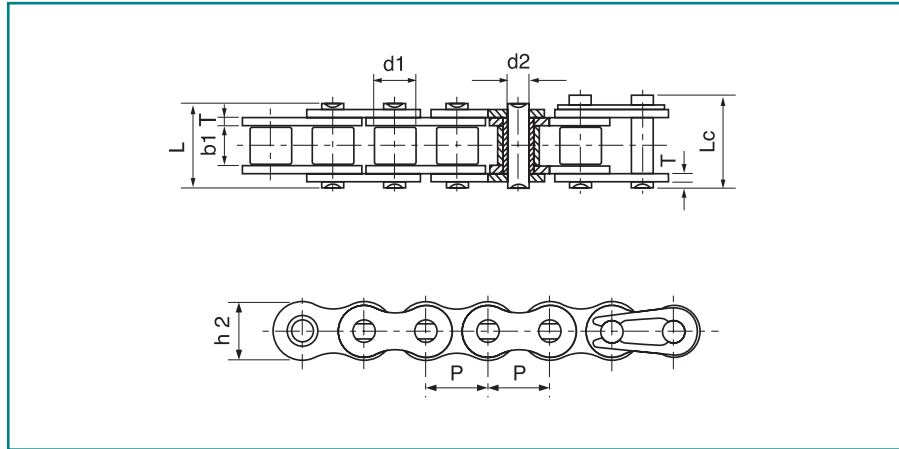

"H" SERIES ROLLER CHAINS

ANSI "H" Series chains are dimensionally identical to ANSI standard chains except that the sideplates are thicker. The heavier side plates provide some additional fatigue resistance. They are primarily intended for applications where occasional shock loads are likely to cause fatigue failures in the chain. Whilst there is an increase in tensile strength, the wear life of the case hardened pins remains the same as for standard chain.

Simplex "H" series chains operate on standard ANSI sprockets. Multiple strand "H" chain require non-standard ANSI sprockets because of the thicker side plates.

Product Code	ANSI Chain No	Pitch	Roller Diameter	Width Between Inner Plates	Pin Diameter	Pin Length		Inner Plate Depth	Plate Thickness	Minimum Tensile Strength	Average Tensile Strength	Weight per Metre
		P mm	d1 max mm	b1 min mm	d2 max mm	L max mm	Lc max mm	h2 max mm	T max mm	Q min kN	Qo kN	q kg/m
028L5114	40H	12.700	7.95	7.85	3.96	18.80	19.90	12.00	2.03	14.10	19.10	0.82
028N0114	50H	15.875	10.16	9.40	5.08	22.10	23.40	15.09	2.42	22.20	30.20	1.25
028P0114	60H	19.050	11.91	12.57	5.94	29.20	31.00	18.00	3.25	31.80	42.70	1.87
028Q0114	80H	25.400	15.88	15.75	7.92	36.20	37.70	24.00	4.00	56.70	71.40	3.10
028R0114	100H	31.750	19.05	18.90	9.53	43.60	46.90	30.00	4.80	88.50	112.40	4.52
028S0114	120H	38.100	22.23	25.22	11.10	53.50	57.50	35.70	5.60	127.00	160.90	6.60
028W0114	140H	44.450	25.40	25.22	12.70	57.60	62.20	41.00	6.40	172.40	217.30	8.30
028X0114	160H	50.800	28.58	31.55	14.27	68.20	73.00	47.80	7.20	226.80	285.80	10.30
028Z0114	200H	63.500	39.68	37.85	19.85	86.60	93.50	60.00	9.50	353.80	444.50	19.16

Note; Refer to your local Authorised Distributor for dimensional details of ANSI "H" Series multiple strand chain

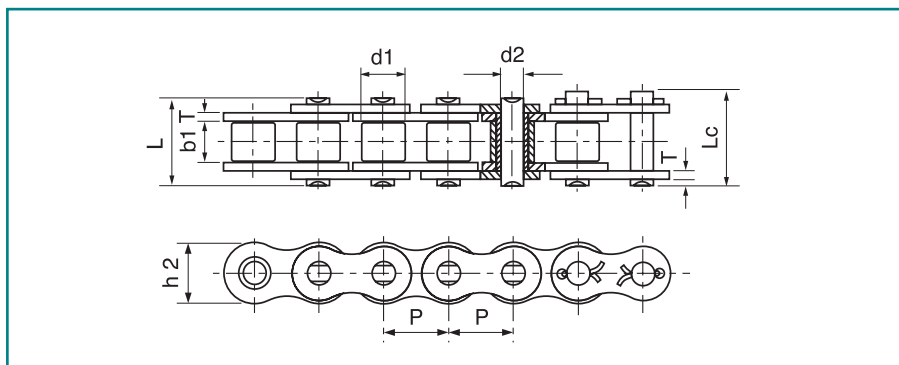

"SH" SERIES ROLLER CHAINS

ANSI "SH" series chains are identical to "H" series but they have a different pin material, which is through hardened. The surface hardness is less than that of the carburised pins in the ANSI standard and ANSI "H" series chains but through hardened pins provide additional fatigue resistance, at some slight sacrifice in wear life.

Simplex "SH" series chains operate on standard ANSI sprockets. Multiple strand "SH" series chain requires non-standard ANSI sprockets because of the thicker side plates.

Product Code	ANSI Chain No	Pitch	Roller Diameter	Width Between Inner Plates	Pin Diameter	Pin Length		Inner Plate Depth	Plate Thickness	Minimum Tensile Strength	Average Tensile Strength	Weight per Metre
		P mm	d1 max mm	b1 min mm	d2 max mm	L max mm	Lc max mm	h2 max mm	T max mm	Q min kN	Qo kN	q kg/m
028L5115	40SH	12.700	7.95	7.85	3.96	18.80	19.90	12.00	2.03	22.40	24.80	0.82
028N0115	50SH	15.875	10.16	9.40	5.08	22.10	23.40	15.09	2.42	30.40	36.20	1.25
028P0115	60SH	19.050	11.91	12.57	5.94	29.20	31.60	18.00	3.25	44.10	50.40	1.87
028Q0115	80SH	25.400	15.88	15.75	7.92	36.20	37.70	24.00	4.00	88.20	93.00	3.10
028R0115	100SH	31.750	19.05	18.90	9.53	43.60	46.90	30.00	4.80	116.60	129.10	4.52
028S0115	120SH	38.100	22.23	25.22	11.10	53.50	57.50	35.70	5.60	158.20	175.30	6.60
028W0115	140SH	44.450	25.40	25.22	12.70	57.60	62.20	41.00	6.40	206.00	266.50	8.30
028X0115	160SH	50.800	28.58	31.55	14.27	68.20	73.00	47.80	7.20	274.00	293.00	10.30
028Z0115	200SH	63.500	39.68	37.85	19.85	86.60	93.50	60.00	9.50	506.10	562.30	19.16

Chain is sold in units of feet or metres, depending on geographical market

ROLLER CHAINS WITH STRAIGHT SIDE PLATES

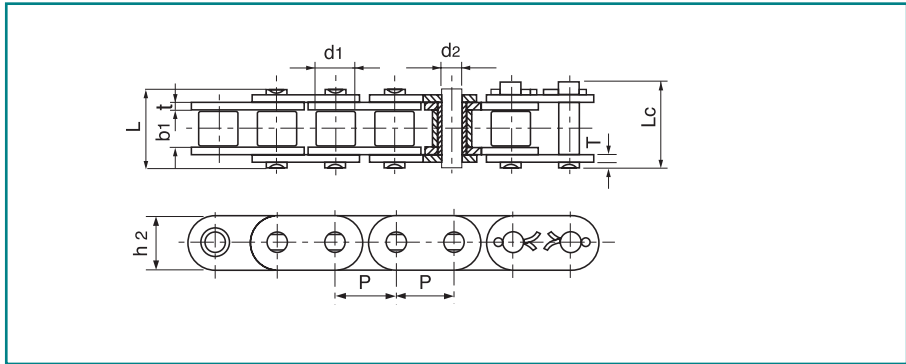

Product Code	DIN ISO Chain No	Pitch	Roller Diameter	Width Between Inner Plates	Pin Diameter	Pin Length		Plate Depth	Plate Thickness	Minimum Tensile Strength	Average Tensile Strength	Weight per Metre
		P mm	d1 max mm	b1 min mm	d2 max mm	L max mm	Lc max mm	h2 max mm	t/T max mm	Q min kN	Q0 kN	q kg/m
028B0410	C08B-1	12.700	8.51	7.75	4.45	16.70	18.20	11.80	1.60	18.00	19.50	0.80
028C0410	C10B-1	15.875	10.16	9.65	5.08	19.50	20.90	14.70	1.70	22.40	27.09	1.06
028D0410	C12B-1	19.050	12.07	11.68	5.72	22.50	25.20	16.00	1.85	29.00	32.20	1.32
028E0410	C16B-1	25.400	15.88	17.02	8.28	36.10	39.10	21.00	4.15/3.1	60.00	72.80	3.08
028E0410	C16B-/24	25.400	15.88	17.02	8.28	36.10	39.10	24.00	4.15/3.1	60.00	72.80	3.49
028F0410	C20B-1	31.750	19.05	19.56	10.19	41.30	45.00	26.40	4.5/3.5	95.00	106.70	4.16
028G0410	C24B-1	38.100	25.40	25.40	14.63	53.40	57.80	33.20	6.0/4.8	160.00	178.00	7.47

Chain is sold in units of feet or metres, depending on geographical market

STAINLESS STEEL CHAINS

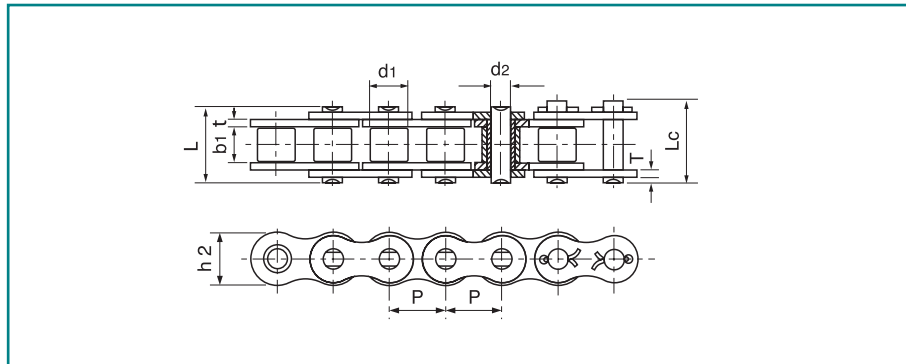

Material: AISI 304 Stainless Steel for optimum corrosion resistance, having regard for tensile strength and wear life considerations. Stainless steel chain is not as hard or as strong as carbon steel chain. AISI 304 Stainless Steel may have some slight residual magnetism due to cold working of the pins, bushes and rollers in manufacture. For applications where non-magnetic chain is required consult your local Authorised Distributor.

Product Code	Chain No	Pitch	Roller Diameter	Width Between Inner Plates	Pin Diameter	Pin Length		Inner Plate Depth	Plate Thickness	Minimum Tensile Strength	Average Tensile Strength	Weight per Metre
		P mm	d1 max mm	b1 min mm	d2 max mm	L max mm	Lc max mm	h2 max mm	t/T mm	Q min kN	Q0 kN	q kg/m
028H0112	04B-1SS	6.000	4.00	2.80	1.85	6.80	7.80	5.00	0.60	2.00	2.40	0.11
028J0112	05B-1SS	8.000	5.00	3.00	2.31	8.20	8.90	7.10	0.80	3.50	4.10	0.20
028A0412	*06B-1SS	9.525	6.35	5.72	3.28	13.15	14.10	8.20	1.30	6.20	6.80	0.41
028B0112	08B-1SS	12.700	8.51	7.75	4.45	16.70	18.20	11.80	1.60	12.00	14.30	0.70
028C0112	10B-1SS	15.875	10.16	9.65	5.08	19.50	20.90	14.70	1.70	14.50	17.20	0.94
028D0112	12B-1SS	19.050	12.07	11.68	5.72	22.50	24.20	16.00	1.85	18.50	20.90	1.16
028E0112	16B-1SS	25.400	15.88	17.02	8.28	36.10	37.40	21.00	4.15/3.1	40.00	47.60	2.73
028F0112	20B-1SS	31.750	19.05	19.56	10.19	41.30	45.00	26.40	4.5/3.5	59.00	69.60	3.73
028K0112	•35SS	9.525	5.08	4.77	3.58	12.40	13.17	9.00	1.30	5.50	6.60	0.33
028L0112	40SS	12.700	7.95	7.85	3.96	16.60	17.80	12.00	1.50	9.60	10.80	0.63
028N0112	50SS	15.875	10.16	9.40	5.08	20.70	22.20	15.00	2.03	15.20	17.20	1.03
028P0112	60SS	19.050	11.91	12.57	5.94	25.90	27.70	18.00	2.42	21.70	26.40	1.51
028Q0112	80SS	25.400	15.88	15.75	7.92	32.70	35.00	24.00	3.25	38.90	46.60	2.62

* Straight Side Plates.

• Bushing chain, d1 indicates the external diameter of the bushing.

Special Chain and Attachment Chain



FENNER SPECIAL CHAINS

Also available are the extended range of "Special" chains which are widely used industrial standards but not part of any ISO or ANSI International Standards.

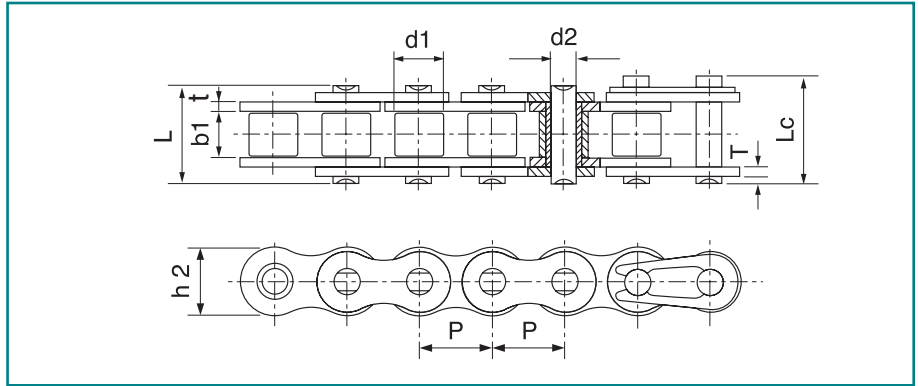

Chain No	Pitch	Roller Diameter	Width Between Inner Plates	Pin Diameter	Pin Length		Inner Plate Depth	Plate Thickness	Minimum Tensile Strength	Average Tensile Strength	Weight per Metre
	P mm	d1 max mm	b1 min mm	d2 max mm	L max mm	Lc max mm	h2 max mm	t/T max mm	Q min kN	Qo kN	q kg/m
04BH	6.00	4.00	2.80	1.85	8.40	9.40	5.00	0.90	5.00	5.30	0.14
415	12.70	7.77	4.76	3.60	11.00	12.40	9.70	1.00	6.86	7.60	0.32
415H	12.70	7.77	4.76	3.96	13.10	14.50	12.00	1.50	14.40	16.10	0.55
415B	12.70	7.75	4.88	4.09	12.90	14.40	10.30	1.30	12.00	14.20	0.44
415BF1	12.70	7.75	4.88	4.09	11.50	13.00	10.30	1.00	9.00	10.60	0.38
423	12.70	8.51	6.40	4.45	15.60	17.10	12.40	1.70	19.60	21.90	0.71
478	12.70	7.80	4.80	4.00	11.60	13.65	10.46	1.25	9.80	12.80	0.39
08BF	12.70	8.51	5.55	4.45	14.60	16.10	11.80	1.60	17.80	19.20	0.66
12BV	19.05	12.07	11.68	6.10	24.50	26.50	16.00	2.42	36.00	39.90	1.43
12BH	19.05	12.07	11.68	5.94	25.20	26.80	16.00	2.42	40.00	44.40	1.45
12BHF1	19.05	12.07	11.68	6.10	25.00	27.20	16.50	2.50	44.00	48.80	1.46
16BF1	25.40	15.88	12.20	8.28	31.40	32.70	21.00	4.15/3.1	60.00	71.40	2.60
16BF2	25.40	15.88	17.02	8.28	38.60	39.80	21.00	4.15	60.00	71.40	3.08
16BF5	25.40	15.88	12.70	8.28	30.80	32.10	20.00	3.5/3.0	50.00	57.50	2.37
16BH	25.40	15.88	17.02	8.90	35.70	38.90	24.10	4.0/3.1	80.00	94.20	3.11
24BH	38.10	25.40	25.40	14.63	58.60	63.40	36.20	7.5/6.0	225.00	250.30	9.00

CHAINS WITH EXTENDED PINS

The following extended pins, for British and ANSI chains, conform generally with the ISO "Standard". Other manufacturers standards may differ in detail.

The critical dimensions are extended length and diameter and requirements should be checked against the dimensions below.

Duplex and triplex pin lengths can be supplied to order.

ISO Chain No	ANSI Chain No	Pitch	Width Between Inner Plates	Pin Diameter	Extended Length	Pin Length	
		P mm	b1 mm	d2 mm	L3 mm	L max mm	Lc max mm
08B		12.700	7.75	4.45	9.50	25.10	26.60
10B		15.875	9.65	5.08	11.90	30.10	31.50
12B		19.050	11.68	5.72	14.30	35.40	37.10
16B		25.400	17.02	8.28	19.10	53.00	54.30
	35	9.525	4.77	3.58	9.50	20.80	21.60
	40	12.700	7.85	3.96	9.50	25.10	26.20
	50	15.875	9.40	5.08	11.90	31.30	33.10
	60	19.050	12.57	5.94	14.30	38.60	40.60
	80	25.400	15.75	7.92	19.10	50.30	53.30
	100	31.750	18.90	9.53	23.80	61.80	66.10
	120	38.100	25.22	11.10	28.60	76.40	80.40
	140	44.450	25.22	12.70	33.30	84.80	89.40
	160	50.800	31.55	14.27	38.10	99.60	104.40

Chain is sold in units of feet or metres, depending on geographical market

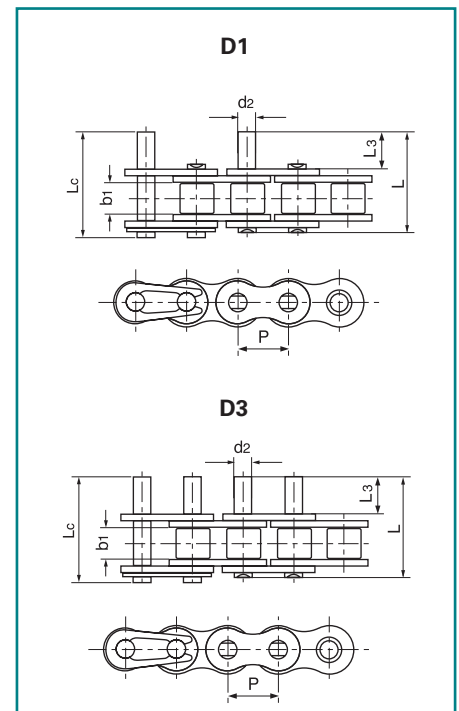

DOUBLE PITCH TRANSMISSION CHAINS

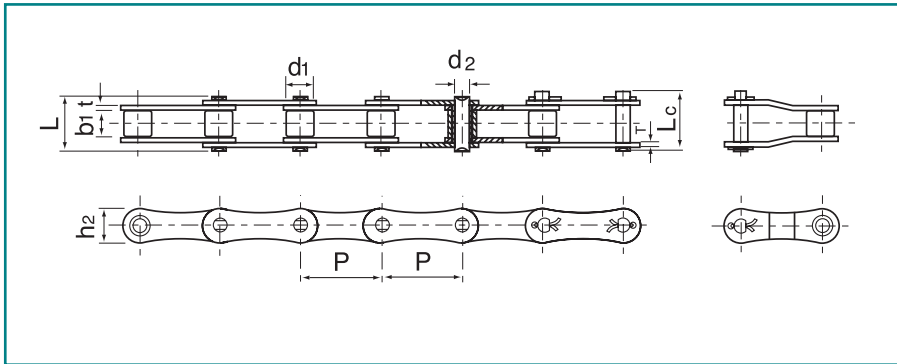

ANSI Chain No	ISO Chain No	Pitch	Roller Diameter	Width Between Inner Plates	Pin Diameter	Pin Length		Inner Plate Depth	Plate Thickness	Minimum Tensile Strength	Average Tensile Strength	Weight per Metre
		P mm	d1 max mm	b1 min mm	d2 max mm	L max mm	Lc max mm	h2 max mm	t/T max mm	Q min kN	Qo kN	q kg/m
A2040	208B	25.40	7.95	7.85	3.96	16.60	17.80	12.00	1.50	14.10	16.70	0.42
		25.40	8.51	7.75	4.45	16.70	18.20	11.80	1.60	18.00	19.40	0.45
A2050	210B	31.75	10.16	9.40	5.08	20.70	22.20	15.00	2.03	22.20	28.10	0.73
		31.75	10.16	9.65	5.08	19.50	20.90	14.70	1.70	22.40	27.50	0.65
A2060	212B	38.10	11.91	12.57	5.94	25.90	27.70	18.00	2.42	31.80	36.80	1.02
		38.10	12.07	11.68	5.72	22.50	25.20	16.00	1.85	29.00	32.20	0.76
A2080	216B	50.80	15.88	15.75	7.92	32.70	36.50	24.00	3.25	56.70	65.70	1.70
		50.80	15.88	17.02	8.28	36.10	39.10	21.00	4.15/3.10	60.00	72.80	1.75

DOUBLE PITCH CONVEYOR CHAINS

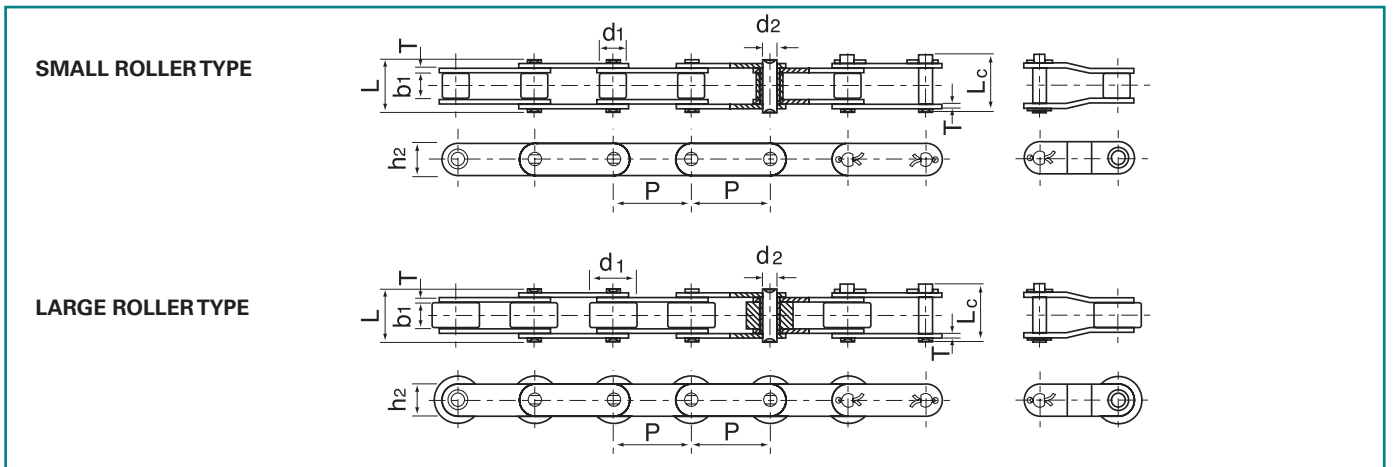

ANSI Chain No	Pitch	Roller Diameter	Width Between Inner Plates	Pin Diameter	Pin Length		Inner Plate Depth	Plate Thickness	Minimum Tensile Strength	Average Tensile Strength	Weight per Metre
	P mm	d1 max mm	b1 min mm	d2 max mm	L max mm	Lc max mm	h2 max mm	T max mm	Q min kN	Qo kN	q kg/m
C2040	25.40	7.95	7.85	3.96	16.60	17.80	12.00	1.50	14.10	16.70	0.50
C2042	25.40	15.88	7.85	3.96	16.60	17.80	12.00	1.50	14.10	16.70	0.84
C2050	31.75	10.16	9.40	5.08	20.70	22.20	15.00	2.03	22.20	28.10	0.78
C2052	31.75	19.05	9.40	5.08	20.70	22.20	15.00	2.03	22.20	28.10	1.27
C2060	38.10	11.91	12.57	5.94	25.90	27.70	18.00	2.42	31.80	36.80	1.12
C2062	38.10	22.23	12.57	5.94	25.90	27.70	18.00	2.42	31.80	36.80	1.61
C2060H	38.10	11.91	12.57	5.94	29.20	31.60	18.00	3.25	31.80	41.60	1.44
C2062H	38.10	22.23	12.57	5.94	29.20	31.60	18.00	3.25	31.80	41.60	2.07
C2080H	50.80	15.88	15.75	7.92	36.20	39.40	24.40	4.00	56.70	70.00	2.54
C2082H	50.80	28.58	15.75	7.92	36.20	39.40	24.40	4.00	56.70	70.00	3.58
C2100H	63.50	19.05	18.90	9.53	43.60	46.90	30.00	4.80	88.50	112.40	3.56
C2102H	63.50	39.67	18.90	9.53	43.60	46.90	30.00	4.80	88.50	112.40	5.38
C2120H	76.20	22.23	25.22	11.10	53.50	57.50	35.70	5.60	127.00	160.90	5.26
C2122H	76.20	44.45	25.22	11.10	53.50	57.50	35.70	5.60	127.00	160.90	8.26

Chain is sold in units of feet or metres, depending on geographical market



HOLLOW PIN CHAINS

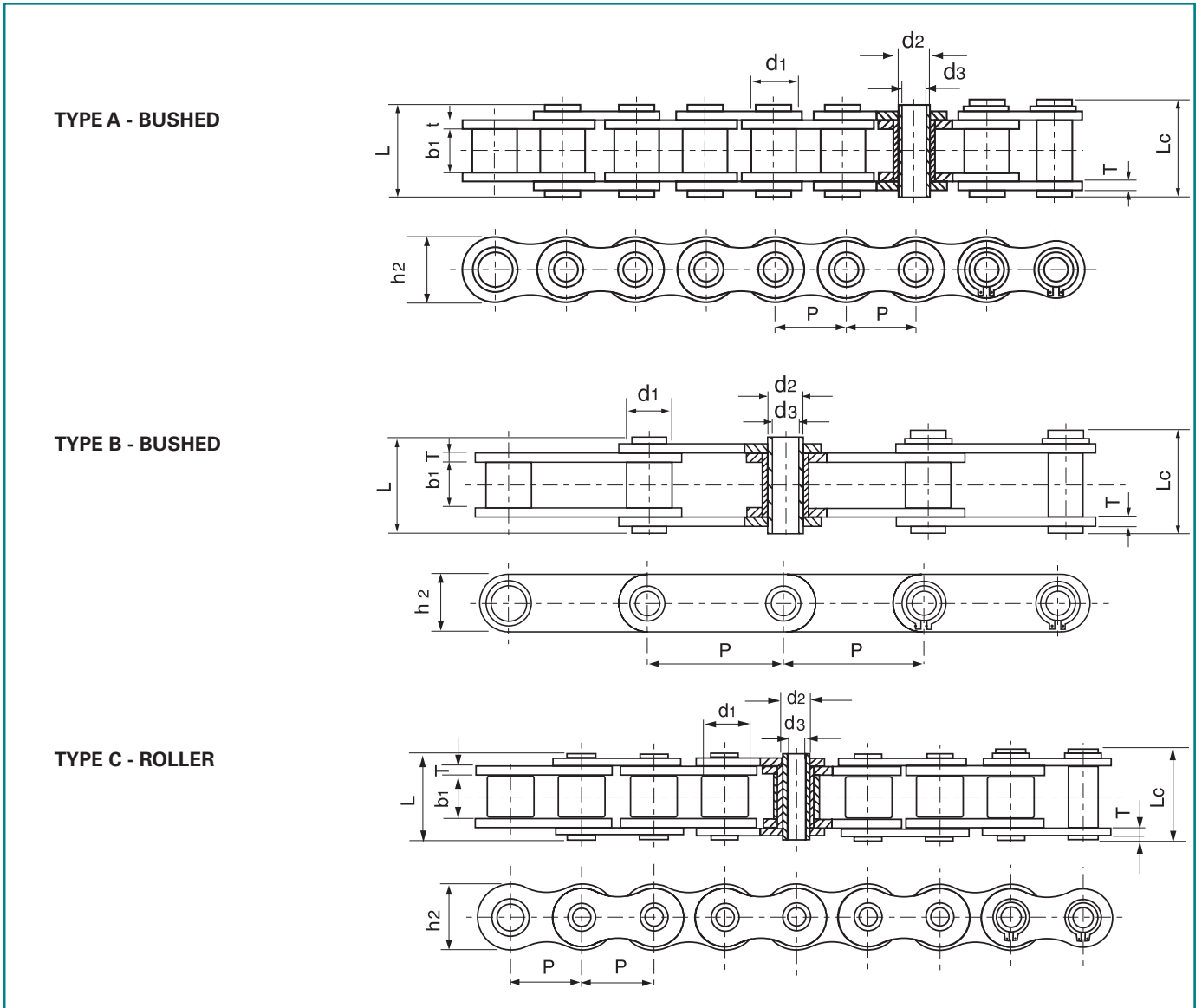

Chain No	Pitch	Bush / Roller Diameter	Width Between Inner Plates	Pin Diameter			Pin Length		Inner Plate Depth	Plate Thickness	Minimum Tensile Strength	Average Tensile Strength	Weight per Metre	Type
	P mm			d1 max mm	b1 min mm	d2 max mm	d3 max mm	L max mm						
08BHP	12.700	8.51	7.75	6.55	4.50	16.40	17.60	11.80	1.60/1.30	11.10	12.10	0.56	A	
10BHP	15.875	10.16	9.65	5.94	4.04	19.30	20.60	14.70	1.70	17.00	20.80	0.86	C	
12BHP	19.050	12.07	11.68	6.50	4.00	21.60	22.80	15.90	1.85	23.60	25.90	1.09	C	
40HP	12.700	7.95	7.85	5.63	4.00	16.50	17.60	12.00	1.50	11.00	12.20	0.54	A	
50HP	15.875	10.16	9.40	7.03	5.13	20.70	21.90	15.09	2.03	20.00	22.60	0.91	A	
60HP/5.01	19.050	11.91	12.70	7.00	5.01	25.50	26.60	18.00	2.42	20.00	22.40	1.35	C	
60HP/6.00	19.050	11.91	12.70	8.31	6.00	25.80	26.80	18.00	2.42	24.00	26.90	1.29	A	
80HP	25.400	15.88	15.75	11.40	8.05	32.50	33.80	24.00	3.25	50.00	58.30	2.26	A	
C2040HP	25.400	7.95	7.85	5.63	4.00	16.50	17.60	12.00	1.50	11.00	12.60	0.46	B	
C2050HP	31.750	10.16	9.40	7.22	5.12	20.50	21.80	15.00	2.03	20.40	22.80	0.76	B	
C2060HP	38.100	11.91	12.70	8.31	6.00	25.80	26.80	18.00	2.42	24.00	27.10	1.02	B	
C2080HP	50.800	15.88	15.75	11.40	8.05	32.50	33.80	24.00	3.25	50.00	55.20	1.81	B	

Chain is sold in units of feet or metres, depending on geographical market

'S' TYPE STEEL AGRICULTURAL CHAINS

All 'S' type chain and attachments can be supplied zinc plated.
Please specify at time of order.

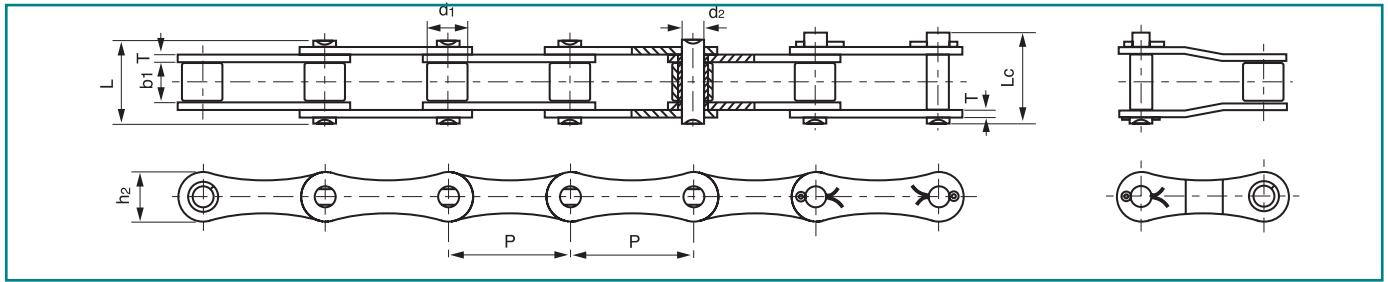

Chain No	Pitch	Roller Diameter	Width Between Inner Plates	Pin Diameter	Pin Length		Inner Plate Depth	Plate Thickness	Minimum Tensile Strength	Average Tensile Strength	Weight per Metre
	P mm	d1 max mm	b1 min mm	d2 max mm	L max mm	Lc max mm	h2 max mm	T max mm	Q mim kN	Qo kN	q kg/m
S32	29.21	11.43	15.88	4.45	26.70	28.80	13.20	1.80	8.00	21.60	0.86
S42	34.93	14.27	19.05	7.00	34.30	37.00	19.80	2.80	27.00	50.80	1.60
S45	41.40	15.24	22.23	5.72	37.70	40.40	17.30	2.80	18.00	36.10	1.66
S52	38.10	15.24	22.23	5.72	37.70	40.40	17.30	2.80	18.00	36.10	1.68
S55	41.40	17.78	22.23	5.72	37.70	40.40	17.30	2.80	18.00	36.10	1.80
S55R	41.40	17.78	22.23	8.90	41.00	44.00	22.40	3.50	45.00	73.10	2.49
S62	41.91	19.05	25.40	5.72	40.30	43.00	17.30	2.50	27.00	36.10	1.87
S77	58.34	18.26	22.23	8.90	43.20	46.40	26.20	4.00	45.00	73.10	2.65
S88	66.27	22.86	28.58	8.90	49.80	53.00	26.20	4.00	45.00	73.10	3.25

'S' TYPE STEEL AGRICULTURAL CHAIN ATTACHMENTS

Chain No	Pitch	Width	Hole Centres	Overall Width	Platform Height	Hole Dia	Elongated Slot Width
	P mm	G mm	F mm	W mm	h4 mm	d4 mm	K mm
S32K1	29.21	15.00	42.90	61.00	8.60	5.30	6.90
S42K1	34.93	17.50	54.00	74.90	14.00	8.30	11.50
S45K1	41.40	22.00	54.00	75.00	11.40	8.50	11.70
S52K1	38.10	19.00	58.80	78.00	11.40	8.30	9.90
S55K1	41.40	22.00	54.00	75.00	11.40	8.50	11.70
S62K1	41.91	22.00	66.80	95.40	11.40	6.50	13.00
S62F2	41.91	22.00	66.80	95.40	11.40	8.30	14.70

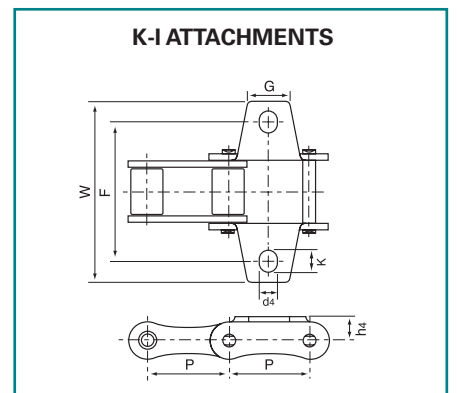

'C' TYPE STEEL AGRICULTURAL CHAINS

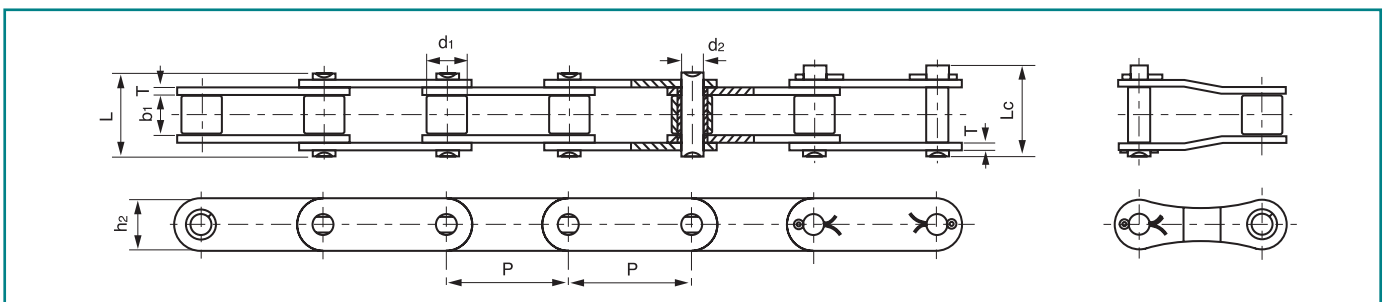

Chain No	Pitch	Roller Diameter	Width Between Inner Plates	Pin Diameter	Pin Length		Inner Plate Depth	Plate Thickness	Minimum Tensile Strength	Average Tensile Strength	Weight per Metre
	P mm	d1 max mm	b1 min mm	d2 max mm	L max mm	Lc max mm	h2 max mm	T max mm	Q mim kN	Qo kN	q kg/m
CA550	41.40	16.87	19.81	7.19	35.00	38.00	19.30	2.80	39.10	51.20	1.94
CA557	41.40	17.78	20.24	8.00	37.40	40.60	23.10	3.10	55.61	74.30	2.20
CA620	42.01	17.91	24.51	7.19	41.80	45.20	20.20	3.25	39.10	55.10	2.35



BL SERIES LEAF CHAINS

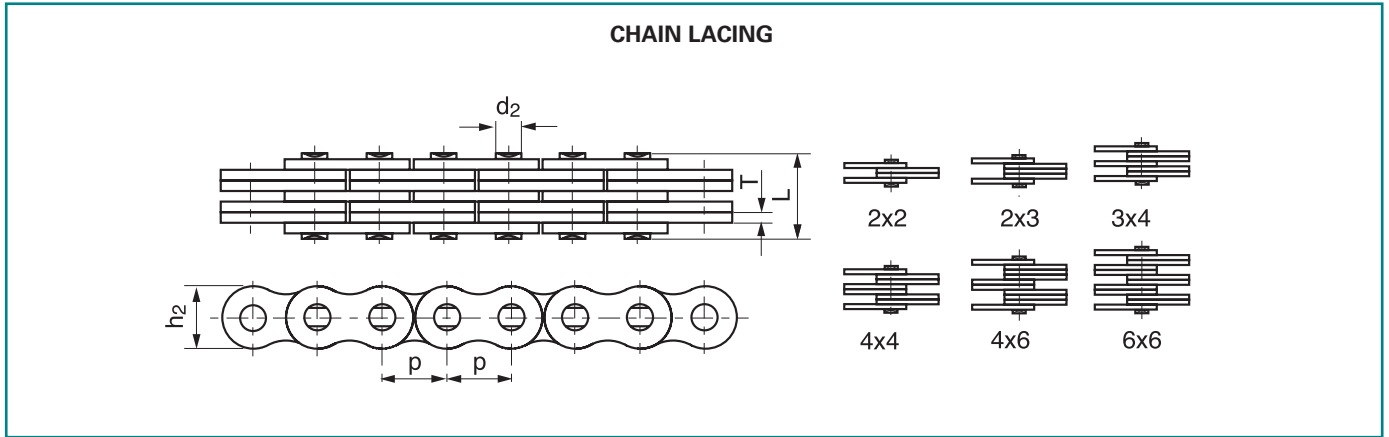

ANSI Chain No	ISO Chain No	Pitch	Chain Lacing	Plate Depth	Plate Thickness	Pin Diameter	Pin Length	Minimum Tensile Strength	Average Tensile Strength	Weight per Metre
		P mm		h2 max mm	T max mm	d2 max mm	L max mm	Q min kN	Qo kN	q kg/m
BL422	LH0822	12.700 1/2"	2x2	12.07	2.08	5.09	11.05	22.20	27.60	0.64
BL423	LH0823		2x3				13.16	22.20	27.60	0.80
BL434	LH0834		3x4				17.40	33.40	41.40	1.12
BL444	LH0844		4x4				19.51	44.50	56.00	1.28
BL446	LH0846		4x6				23.75	44.50	56.00	1.60
BL466	LH0866		6x6				27.99	66.70	81.70	1.92
BL522	LH1022	15.875 5/8"	2x2	15.09	2.44	5.96	12.90	33.40	43.10	0.88
BL523	LH1023		2x3				15.37	33.40	43.10	1.10
BL534	LH1034		3x4				20.32	48.90	65.60	1.50
BL544	LH1044		4x4				22.78	66.70	84.50	1.80
BL546	LH1046		4x6				27.74	66.70	84.50	2.20
BL566	LH1066		6x6				32.69	100.10	125.10	2.65
BL622	LH1222	19.050 3/4"	2x2	18.11	3.30	7.94	17.37	48.90	63.60	1.45
BL623	LH1223		2x3				20.73	48.90	63.60	1.80
BL634	LH1234		3x4				27.43	75.60	102.80	2.50
BL644	LH1244		4x4				30.78	97.90	120.90	2.90
BL646	LH1246		4x6				37.49	97.90	120.90	3.60
BL666	LH1266		6x6				44.20	146.80	190.80	4.30
BL822	LH1622	25.400 1"	2x2	24.13	4.09	9.54	21.34	84.50	108.20	2.20
BL823	LH1623		2x3				25.48	84.50	108.20	2.70
BL834	LH1634		3x4				33.76	129.00	170.00	3.80
BL844	LH1644		4x4				37.90	169.00	214.60	4.30
BL846	LH1646		4x6				46.18	169.00	214.60	5.40
BL866	LH1666		6x6				54.46	253.60	324.50	6.50
BL1022	LH2022	31.750 1.1/4"	2x2	30.18	4.90	11.11	25.37	115.60	150.80	3.40
BL1023	LH2023		2x3				30.33	115.60	150.80	4.30
BL1034	LH2034		3x4				40.23	182.40	231.60	6.00
BL1044	LH2044		4x4				45.19	231.30	291.40	6.90
BL1046	LH2046		4x6				55.09	231.30	291.40	8.60
BL1066	LH2066		6x6				65.00	347.00	430.30	10.30
BL1222	LH2422	38.100 1.1/2"	2x2	36.20	5.77	12.71	29.62	151.20	192.00	4.60
BL1223	LH2423		2x3				35.43	151.20	192.00	5.80
BL1234	LH2434		3x4				47.07	244.60	315.90	8.10
BL1244	LH2444		4x4				52.88	302.50	381.10	9.30
BL1246	LH2446		4x6				64.52	302.50	381.10	11.60
BL1266	LH2466		6x6				76.15	453.70	543.60	13.90
BL1422	LH2822	44.450 1.3/4"	2x2	42.24	6.55	14.29	33.55	191.30	225.70	6.10
BL1423	LH2823		2x3				40.16	191.30	225.70	7.60
BL1434	LH2834		3x4				53.37	315.80	372.60	10.60
BL1444	LH2844		4x4				59.97	382.60	451.20	12.20
BL1446	LH2846		4x6				73.18	382.60	451.20	15.20
BL1466	LH2866		6x6				86.39	578.30	682.40	18.20
BL1622	LH3222	50.800 2"	2x2	48.26	7.52	17.46	39.01	289.10	341.10	8.00
BL1623	LH3223		2x3				46.58	289.10	341.10	10.00
BL1634	LH3234		3x4				61.72	440.40	519.60	14.00
BL1644	LH3244		4x4				69.29	578.30	680.40	16.00
BL1646	LH3246		4x6				84.43	578.30	680.40	20.00
BL1666	LH3266		6x6				99.57	857.40	1000.70	24.00

LL SERIES LEAF CHAINS

ISO Chain No	Pitch	Chain Lacing	Plate Depth	Plate Thickness	Pin Diameter	Pin Length	Minimum Tensile Strength	Average Tensile Strength	Weight per Metre
	P mm		h2 max mm	T max mm	d2 max mm	L max mm	Q min kN	Q0 kN	q kg/m
LL0822	12.700 1/2"	2x2	10.60	1.30	4.45	7.60	17.80	20.40	0.35
LL0844		4x4				13.00	31.10	35.70	0.69
LL0866		6x6				18.20	44.50	50.90	1.00
LL1022	15.875 5/8"	2x2	13.70	1.60	5.08	9.20	22.30	25.50	0.54
LL1044		4x4				15.80	44.50	51.00	1.06
LL1066		6x6				22.10	66.70	76.30	1.57
LL1088		8x8				28.80	89.00	101.90	2.10
LL1222	19.050 3/4"	2x2	16.00	1.85	5.72	10.40	28.90	33.20	0.73
LL1244		4x4				17.90	57.80	66.40	1.44
LL1266		6x6				25.40	86.70	99.70	2.15
LL1288		8x8				32.90	115.60	132.90	2.84
LL1622	25.400 1"	2X2	21.0	3.10	8.28	17.20	58.00	66.70	1.52
LL1644		4X4				29.60	144.00	164.60	2.90
LL1666		6X6				42.40	200.00	230.00	4.30
LL1688		8X8				55.40	288.00	331.20	5.71
LL2022	31.750 1.1/4"	2X2	26.40	3.70	10.19	20.10	95.00	109.20	2.33
LL2044		4X4				33.80	190.00	218.50	4.40
LL2066		6X6				50.10	285.00	324.60	6.79
LL2088		8X8				65.40	380.00	435.10	8.75
LL2422	38.100 1.1/2"	2X2	33.40	5.00	14.63	28.40	170.00	195.50	4.47
LL2444		4X4				46.30	340.00	380.80	8.22
LL2466		6X6				66.40	510.00	571.20	12.22
LL2488		8X8				86.60	680.00	775.20	16.30
LL2822	44.450 1.3/4"	2X2	37.08	6.00	15.90	32.20	200.00	224.00	5.10
LL2844		4X4				56.40	400.00	448.00	9.90
LL2866		6X6				80.60	600.00	672.00	14.60
LL2888		8X8				105.20	800.00	896.00	19.40
LL3222	50.800 2"	2X2	42.00	6.00	17.81	33.20	260.00	291.20	5.80
LL3244		4X4				57.40	520.00	582.40	11.40
LL3266		6X6				81.60	780.00	873.60	16.90
LL3288		8X8				105.00	1050.00	1176.00	24.00
LL4022	63.500 2.1/2"	2X2	52.76	8.25	22.89	44.70	360.00	703.20	10.30
LL4044		4X4				77.90	780.00	873.60	20.00
LL4066		6X6				111.10	1080.00	1209.60	29.50
LL4088		8X8				145.50	1560.00	1747.20	39.10
LL4822	76.200 3"	2X2	63.88	10.30	29.24	56.10	560.00	627.20	18.50
LL4844		4X4				97.40	1120.00	1554.40	35.70
LL4866		6X6				138.90	1168.00	1308.10	53.00
LL4888		8X8				182.40	2240.00	2508.80	70.40

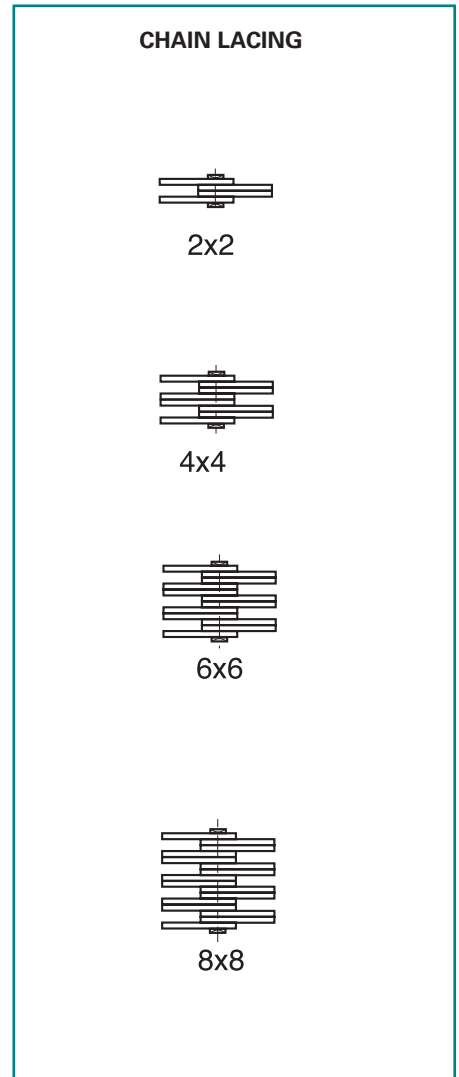

AL SERIES LEAF CHAINS

ANSI Chain No	Pitch	Chain Lacing	Plate Depth	Plate Thickness	Pin Diameter	Pin Length	Minimum Tensile Strength	Average Tensile Strength	Weight per Metre
	P mm		h2 max mm	T max mm	d2 max mm	L max mm	Q min kN	Q0 kN	q kg/m
AL322	9.525 3/8"	2X2	7.70	1.30	3.58	6.80	9.00	10.20	0.23
AL422	12.700 1/2"	2X2	10.40	1.50	3.96	7.90	14.10	16.90	0.39
AL444		4X4				14.40	28.20	35.20	0.74
AL466		6X6				20.50	42.30	52.70	1.10
AL522	15.875 5/8"	2X2	12.80	2.03	5.08	10.30	22.00	27.50	0.61
AL534		3X4				17.00	33.00	46.00	1.10
AL544		4X4				18.90	44.00	55.00	1.19
AL566		6X6				26.90	66.00	82.50	1.79
AL622	19.050 3/4"	2X2	15.60	2.42	5.94	12.40	37.00	44.40	0.86
AL644		4X4				22.70	64.00	78.80	1.69
AL666		6X6				32.40	101.00	118.60	2.52
AL822	25.400 1"	2X2	20.50	3.25	7.92	16.00	56.70	68.60	1.54
AL844		4X4				29.40	113.40	135.60	3.00
AL866		6X6				42.50	170.00	202.30	4.46
AL1022	31.750 1.1/4"	2X2	25.60	4.00	9.53	19.60	88.50	107.10	2.37
AL1044		4X4				35.90	177.00	203.60	4.68
AL1066		6X6				52.30	265.00	315.30	7.00
AL1222	38.100 1.1/2"	2X2	30.50	4.80	11.10	24.30	127.00	151.10	3.65
AL1244		4X4				43.80	254.00	299.70	7.05
AL1266		6X6				63.00	381.00	426.30	10.44
AL1444		4X4				51.30	372.70	413.60	10.34
AL1466	6X6	74.56	559.00	620.40	15.16				
AL1644	50.800 2"	4X4	41.60	6.40	14.21	58.06	471.00	522.80	12.98
AL1666		6X6				84.46	706.00	783.60	19.41

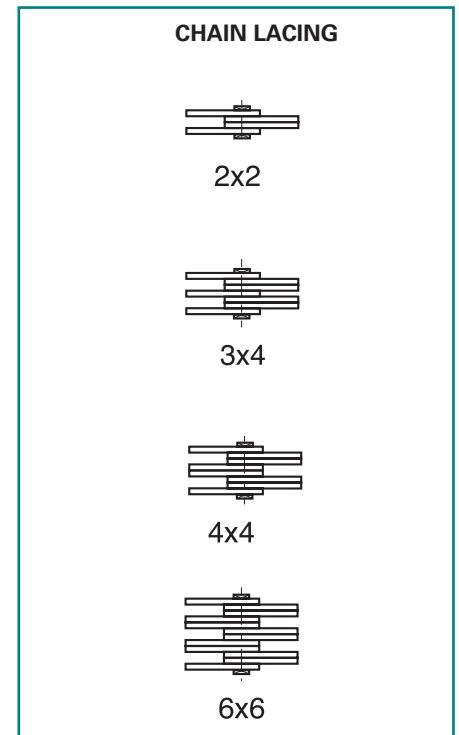



Fenner[®] PLUS

High Performance Sprockets
Hardened teeth for a longer life.

Fenner PLUS sprockets have been re-engineered to become the perfect partner for the new Fenner PLUS roller chain.

All Fenner PLUS sprockets up to circa 40 teeth are manufactured from C45 grade steel - a 0.45% plain carbon steel ideally suited to through hardening.

Hardened Teeth:

Fenner PLUS steel sprockets up to circa 40 teeth have hardened teeth - hardened to just below the tooth root.

Increased Life:

The superior hardened sprocket dramatically improves both chain and sprocket life by up to 50%.

Reduced Noise:

The teeth on Fenner PLUS sprockets are carefully hardened to specified levels, allowing accurate mesh to be maintained longer and therefore reducing drive noise.



Use with Fenner PLUS high performance chain for exceptional performance and value.

www.fptgroup.com

BUILT TO LAST

EXCEPTIONAL PERFORMANCE FOR EVERYDAY USE

STEEL C45

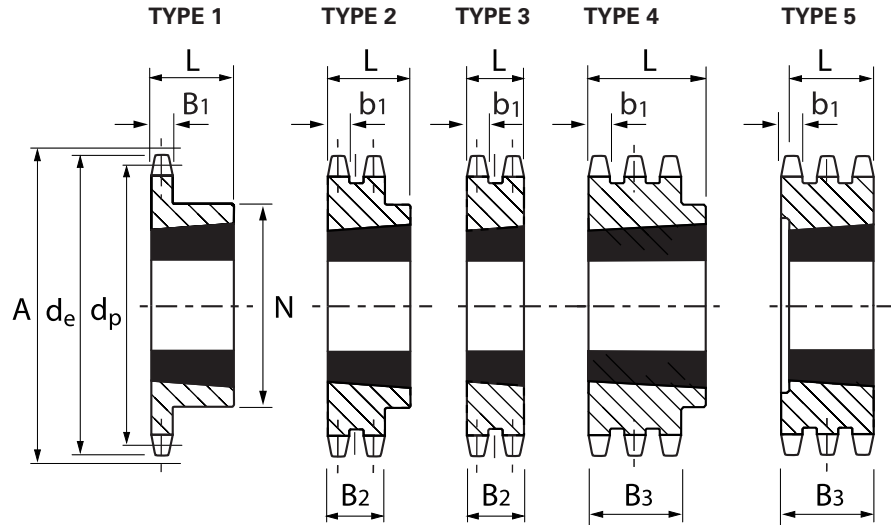

CAST IRON GG22

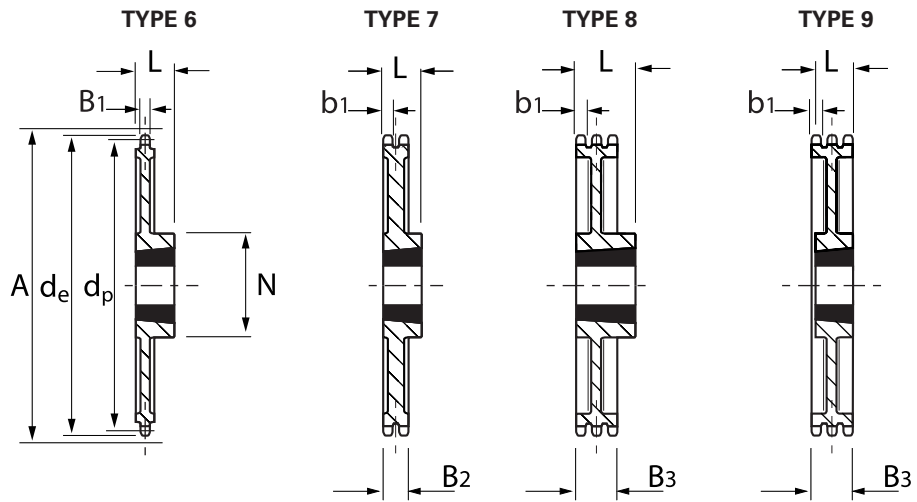

06B T/L SPROCKET

3/8" (9.5mm) PITCH

Tooth Width

- B₁ 5.3mm
- b₁ 5.2mm
- B₂ 15.4mm
- B₃ 25.6mm

No. of Teeth	Pitch Dia	Outer Dia	Dia Over Chain	Simplex Taper Lock						Duplex Taper Lock						Triplex Taper Lock					
				Product code	Designation	Bush No.	Type	Length Bore		Product code	Designation	Bush No.	Type	Length Bore		Product code	Designation	Bush No.	Type	Length Bore	
								L mm	N mm					L mm	N mm					L mm	N mm
17	51.84	56	60	026A*117	31-17	1008	1	22.2	45	026A*217	32-17	1008	2	22.2	45	026A*317	33-17	1008	5	25.6	
19	57.86	62	66	026A*119	31-19	1008	1	22.2	45	026A*219	32-19	1008	2	22.2	45	026A*319	33-19	1008	5	25.6	
20	60.89	64	68	026A*120	31-20	1008	1	22.2	46												
21	63.91	68	72	026A*121	31-21	1008	1	22.2	46	026A*221	32-21	1008	2	22.2	49	026A*321	33-21	1008	5	25.6	
23	69.95	74	78	026A*123	31-23	1210	1	25.4	63	026A*223	32-23	1210	2	25.4	59	026A*323	33-23	1210	5	25.6	
25	76.00	80	84	026A*125	31-25	1210	1	25.4	63	026A*225	32-25	1210	2	25.4	65	026A*325	33-25	1210	5	25.6	
27	82.05	86	90	026A*127	31-27	1210	1	25.4	63	026A*227	32-27	1210	2	25.4	70	026A*327	33-27	1210	5	25.6	
30	91.12	95	99	026A*130	31-30	1210	1	25.4	63	026A*230	32-30	1210	2	25.4	75	026A*330	33-30	1615	4	38.0	79
38	115.34	119	123	026A*138	31-38	1210	1	25.4	70	026A*238	32-38	1610	2	25.4	80	026A*338	33-38	1615	4	38.0	90
45	136.55	141	145	026A0145	31-45	1210	1	25.4	70	026A0245	32-45	1610	2	25.4	80						
57	172.90	177	181	026A0157	31-57	1210	6	25.4	83	026A0257	32-57	1610	7	25.4	80						
76	230.48	234	239	026A0176	31-76	1210	6	25.4	83	026A0276	32-76	1610	7	25.4	92						
95	288.08	292	296	026A0195	31-95	1210	6	25.4	83	026A0295	32-95	1610	7	25.4	92						

Taper Lock bushes supplied as a separate items

For Fenner PLUS sprocket order reference substitute * for 9 for Fenner standard sprockets substitute * for 0

Cast iron sprockets do not have hardened teeth

Taper Lock® Sprockets



08B T/L SPROCKET 1/2" (12.7mm) PITCH

Tooth Width

B ₁	7.2mm
b ₁	7.0mm
B ₂	21.0mm
B ₃	34.9mm

No. of Teeth	Pitch Dia	Outer Dia	Dia Over Chain	Simplex Taper Lock						Duplex Taper Lock						Triplex Taper Lock								
				Product code	Designation	Bush No.	Type	Length Bore		Hub Dia	Product code	Designation	Bush No.	Type	Length Bore		Hub Dia	Product code	Designation	Bush No.	Type	Length Bore		Hub Dia
								L	N						L	N						L	N	
mm	mm	mm	mm	mm	mm	mm	mm	mm	mm	mm	mm	mm	mm	mm	mm	mm	mm	mm	mm	mm	mm	mm		
15	61.09	66	73	026B*115	41-15	1008	1	22.2	45	026B*215	42-15	1008	2	22.2	46	026B*315	43-15	1008	5	34.9				
17	69.11	74	81	026B*117	41-17	1210	1	25.4	60	026B*217	42-17	1210	2	25.4	56	026B*317	43-17	1210	5	34.9				
19	77.17	82	89	026B*119	41-19	1210	1	25.4	63	026B*219	42-19	1210	2	25.4	62	026B*319	43-19	1210	5	34.9				
20	81.19	86	93	026B*120	41-20	1610	1	25.4	65															
21	85.22	90	97	026B*121	41-21	1610	1	25.4	71	026B*221	42-21	1610	2	25.4	70	026B*321	43-21	1610	5	34.9				
23	93.27	99	106	026B*123	41-23	1610	1	25.4	76	026B*223	42-23	1610	2	25.4	79	026B*323	43-23	1610	5	34.9				
25	101.32	106	113	026B*125	41-25	1610	1	25.4	76	026B*225	42-25	2012	2	32.0	87	026B*325	43-25	2012	5	34.9				
27	109.40	114	121	026B*127	41-27	1610	1	25.4	76	026B*227	42-27	2012	2	32.0	87	026B*327	43-27	2012	5	34.9				
30	121.50	126	133	026B*130	41-30	2012	1	32.0	90	026B*230	42-30	2012	2	32.0	87	026B*330	43-30	2012	5	34.9				
38	153.80	159	166	026B*138	41-38	2012	1	32.0	90	026B*238	42-38	2012	2	32.0	100	026B*338	43-38	2012	5	34.9				
45	182.07	188	195	026B0145	41-45	2012	1	32.0	100	026B0245	42-45	2012	2	32.0	100									
57	230.53	236	243	026B0157	41-57	2012	6	32.0	110	026B0257	42-57	2012	7	32.0	110									
76	307.31	312	319	026B0176	41-76	2012	6	32.0	110	026B0276	42-76	2012	7	32.0	110									
95	384.10	389	396	026B0195	41-95	2012	6	32.0	110	026B0295	42-95	2012	7	32.0	110									

Taper Lock bushes supplied as a separate item

For Fenner PLUS sprocket order reference substitute * for 9 for Fenner standard sprockets substitute * for 0
Cast iron sprockets do not have hardened teeth

10B T/L SPROCKET 5/8" (15.9mm) PITCH

Tooth Width

B ₁	9.1mm
b ₁	9.0mm
B ₂	25.5mm
B ₃	42.1mm

No. of Teeth	Pitch	Outer Dia	Dia Over Chain	Simplex Taper Lock						Duplex Taper Lock						Triplex Taper Lock								
				Product code	Designation	Bush No.	Type	Length Bore		Hub Dia	Product code	Designation	Bush No.	Type	Length Bore		Hub Dia	Product code	Designation	Bush No.	Type	Length Bore		Hub Dia
								L	N						L	N						L	N	
mm	mm	mm	mm	mm	mm	mm	mm	mm	mm	mm	mm	mm	mm	mm	mm	mm	mm	mm	mm	mm	mm	mm	mm	
13	66.34	73	81	026C*113	51-13	1008	1	22.2	47															
15	76.35	83	91	026C*115	51-15	1210	1	25.4	60	026C*215	52-15	1210	3	25.4		026C*315	53-15	1210	5	42.1				
17	86.39	93	101	026C*117	51-17	1610	1	25.4	71	026C*217	52-17	1610	3	25.4		026C*317	53-17	1210	5	42.1				
19	96.44	103	111	026C*119	51-19	1610	1	25.4	75	026C*219	52-19	1610	3	25.4		026C*319	53-19	1615	5	42.1				
20	101.49	108	116	026C*120	51-20	1610	1	25.4	76															
21	106.50	114	122	026C*121	51-21	1610	1	25.4	76	026C*221	52-21	1610	3	25.4		026C*321	53-21	1615	5	42.1				
23	116.59	124	132	026C*123	51-23	1610	1	25.4	76	026C*223	52-23	1610	3	25.4		026C*323	53-23	2012	5	42.1				
25	126.67	134	142	026C*125	51-25	2012	1	32.0	90	026C*225	52-25	2012	2	32.0	90	026C*325	53-25	2517	4	45.0	105			
27	136.75	144	152	026C*127	51-27	2012	1	32.0	90	026C*227	52-27	2012	2	32.0	90	026C*327	53-27	2517	4	45.0	110			
30	151.87	159	167	026C*130	51-30	2012	1	32.0	90	026C*230	52-30	2012	2	32.0	90	026C*330	53-30	2517	4	45.0	120			
38	192.23	200	208	026C*138	51-38	2012	1	32.0	100															
45	227.58	235	243	026C0145	51-45	2012	6	32.0	100															
57	288.19	296	304	026C0157	51-57	2012	6	32.0	110															
76	384.15	392	400	026C0176	51-76	2012	6	32.0	110															

Taper Lock bushes supplied as a separate items

For Fenner PLUS sprocket order reference substitute * for 9 for Fenner standard sprockets substitute * for 0
Cast iron sprockets do not have hardened teeth

12B T/L SPROCKET 3/4" (19.0mm) PITCH

Tooth Width
 B1 11.1mm
 b1 10.8mm
 B2 30.3mm
 B3 49.8mm

No. of Teeth	Pitch Dia	Outer Dia	Dia Over Chain	Simplex Taper Lock						Duplex Taper Lock						Triplex Taper Lock							
				Product code	Designation	Bush No.	Type	Length Bore		Hub Dia	Product code	Designation	Bush No.	Type	Length Bore		Hub Dia	Product code	Designation	Bush No.	Type	Length Bore	
								L mm	N mm						L mm	N mm						L mm	N mm
13	79.60	88	96	026D*113	61-13	1210	1	25.4	60														
15	91.62	100	108	026D*115	61-15	1610	1	25.4	70	026D*215	62-15	1610	3	25.4		026D*315	63-15	1615	5	49.8			
17	103.68	112	120	026D*117	61-17	1610	1	25.4	76	026D*217	62-17	1610	3	25.4		026D*317	63-17	2012	5	49.8			
19	115.75	124	132	026D*119	61-19	2012	1	32.0	90	026D*219	62-19	2012	2	32.0	90	026D*319	63-19	2012	5	49.8			
20	121.78	130	138	026D*120	61-20	2012	1	32.0	95														
21	127.81	136	144	026D*121	61-21	2517	1	44.5	102	026D*221	62-21	2517	2	44.5	108	026D*321	63-21	2517	5	49.8			
23	139.90	149	157	026D*123	61-23	2517	1	44.5	108	026D*223	62-23	2517	2	44.5	108	026D*323	63-23	2517	5	49.8			
25	151.99	160	168	026D*125	61-25	2517	1	44.5	108	026D*225	62-25	2517	2	44.5	130	026D*325	63-25	2517	5	49.8			
27	164.09	172	180	026D*127	61-27	2517	1	44.5	108	026D*227	62-27	2517	2	44.5	130	026D*327	63-27	3020	4	50.8	140		
30	182.25	191	197	026D*130	61-30	2517	1	44.5	108	026D*230	62-30	2517	2	44.5	130	026D*330	63-30	3020	4	50.8	140		
38	230.68	239	247	026D*138	61-38	2517	1	44.5	108	026D*238	62-38	3020	2	50.8	140	026D*338	63-38	3020	4	50.8	140		
45	273.10	283	291	026D0145	61-45	2517	6	44.5	108	026D0245	62-45	3020	7	50.8	140	026D0345	63-45	3020	4	50.8	140		
57	345.82	355	363	026D0157	61-57	2517	6	44.5	124	026D0257	62-57	3020	7	50.8	160	026D0357	63-57	3020	8	50.8	150		
76	460.98	470	478	026D0176	61-76	2517	6	44.5	124	026D0276	62-76	3020	7	50.8	160	026D0376	63-76	3020	8	50.8	160		
95	576.17	585	593	026D0195	61-95	2517	6	44.5	124	026D0295	62-95	3020	7	50.8	160								

Taper Lock bushes supplied as a separate item

For Fenner PLUS sprocket order reference substitute * for 9 for Fenner standard sprockets substitute * for 0
 Cast iron sprockets do not have hardened teeth

16B T/L SPROCKET 1" (25.4mm) PITCH

Tooth Width
 B1 16.2mm
 b1 15.8mm
 B2 47.7mm
 B3 79.6mm

No. of Teeth	Pitch Dia	Outer Dia	Dia Over Chain	Simplex Taper Lock						Duplex Taper Lock						Triplex Taper Lock							
				Product code	Designation	Bush No.	Type	Length Bore		Hub Dia	Product code	Designation	Bush No.	Type	Length Bore		Hub Dia	Product code	Designation	Bush No.	Type	Length Bore	
								L mm	N mm						L mm	N mm						L mm	N mm
13	106.15	117	127	026E*113	81-13	1615	1	38.1	73														
15	122.17	133	143	026E*115	81-15	1615	1	38.1	76	026E*215	82-15	2012	3	32.0		026E*317	83-17	2517	5	76.2			
17	138.23	149	159	026E*117	81-17	2012	1	32.0	90	026E*217	82-17	2517	3	44.5		026E*319	83-19	3030	5	76.2			
19	154.33	165	175	026E*119	81-19	2517	1	44.5	108	026E*219	82-19	2517	3	44.5									
20	162.38	173	183	026E*120	81-20	2517	1	44.5	108	026E*220	82-20	2517	3	44.5									
21	170.43	181	191	026E*121	81-21	2517	1	44.5	110	026E*221	82-21	3020	2	50.8	140	026E*321	83-21	3030	5	76.2			
23	186.54	198	208	026E*123	81-23	2517	1	44.5	110	026E*223	82-23	3020	2	50.8	140	026E*323	83-23	3525	5	89.0			
25	202.67	214	224	026E*125	81-25	2517	1	44.5	110	026E*225	82-25	3020	2	50.8	140	026E*325	83-25	3525	5	89.0			
27	218.79	230	240	026E*127	81-27	2517	1	44.5	110	026E*227	82-27	3020	2	50.8	140	026E*327	83-27	3525	5	89.0			
30	243.00	254	264	026E*130	81-30	3020	1	50.8	140	026E*230	82-30	3020	2	76.2	140	026E*330	83-30	3525	5	89.0			
38	307.59	321	331	026E*138	81-38	3020	6	50.8	140	026E*238	82-38	3020	7	76.2	140	026E*338	83-38	3525	9	89.0	175		
45	364.13	377	387	026E0145	81-45	3020	6	50.8	140	026E0245	82-45	3020	7	76.2	140	026E0345	83-45	4030	9	102.0	215		
57	461.09	474	484	026E0157	81-57	3020	6	50.8	157	026E0257	82-57	3525	7	89.0	175	026E0357	83-57	4030	9	102.0	215		
76	614.63	627	637	026E0176	81-76	3020	6	50.8	157	026E0276	82-76	3525	7	89.0	175	026E0376	83-76	4030	9	102.0	215		

Taper Lock bushes supplied as a separate item

For Fenner PLUS sprocket order reference substitute * for 9 for Fenner standard sprockets substitute * for 0
 Cast iron sprockets do not have hardened teeth

Pilot Bored Sprockets



05B PILOT BORED SPROCKET

8 X 3mm PITCH

No. of Teeth	Pitch Dia dp	Outer Dia de	Simplex (027 J01--)				Duplex (027 J02--)			
			Hub Dia	Length Bore	Stock Bore	Type	Hub Dia	Length Bore	Stock Bore	Type
			N	L	D		N	L	D	
8	20.90	24.00	13	12	6	A	13	18	8	A
9	23.39	26.60	15	12	6	A	15	18	8	A
10	25.89	29.20	17	12	8	A	17	18	8	A
11	28.39	31.70	18	13	8	A	19	18	8	A
12	30.91	34.20	20	13	8	A	21	18	8	A
13	33.42	36.70	23	13	8	A	24	18	8	A
14	35.95	39.20	25	13	8	A	26	18	8	A
15	38.48	41.70	28	13	8	A	29	18	8	A
16	41.01	44.30	30	14	8	A	32	20	10	A
17	43.53	46.80	30	14	8	A	34	20	10	A
18	46.07	49.30	30	14	8	A	37	20	10	A
19	48.61	51.90	30	14	8	A	39	20	10	A
20	51.14	54.40	30	14	8	A	40	20	10	A
21	53.68	57.00	35	14	8	A	40	20	10	A
22	56.21	59.50	35	14	8	A	40	20	10	A
23	58.75	62.00	35	14	8	A	40	20	10	A
24	61.29	64.60	35	14	8	A	40	20	10	A
25	63.83	67.50	35	14	8	A	40	20	10	A
26	66.37	69.50	40	16	10	A	50	22	12	A
27	68.91	72.20	40	16	10	A	50	22	12	A
28	71.45	74.80	40	16	10	A	50	22	12	A
29	73.99	77.30	40	16	10	A	50	22	12	A
30	76.53	79.80	40	16	10	A	50	22	12	A
31	79.08	82.40	40	16	10	A	60	22	12	A
32	81.61	84.90	40	16	10	A	60	22	12	A
33	84.16	87.50	40	16	10	A	60	22	12	A
34	86.70	90.00	40	16	10	A	60	22	12	A
35	89.25	92.50	40	16	10	A	60	22	12	A
36	91.79	95.00	40	16	10	A	60	22	12	A
37	94.33	97.60	40	16	10	A	60	22	12	A
38	96.88	100.20	40	16	10	A	60	22	12	A
39	99.42	102.70	40	16	10	A	60	22	12	A
40	101.97	105.30	40	16	10	A	60	22	12	A
45	114.69	118.00	58	20	10	A	78	38	12	A
57	145.22	148.60	78	20	10	A	78	38	12	A
76	193.59	197.70	78	34	10	A	78	38	12	A
95	241.96	246.10	78	34	10	A	88	43	12	A
114	290.33	294.50	88	39	10	A	88	43	12	A

Tooth Width
 B1 2.8mm
 b1 2.7mm
 B2 8.3mm

Type A = Steel C45
 Type B = Cast Iron GG22

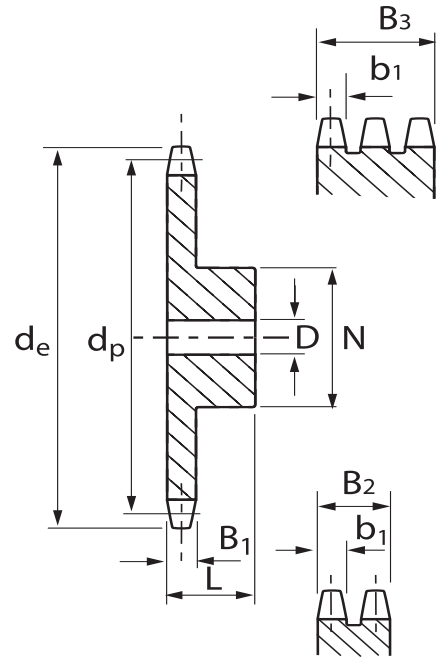

Type A = Steel C45
 Type B = Cast Iron GG22

To complete the product code insert the number of teeth required (027J0109 = 05B-1 8mm pitch 9 tooth pilot bore sprocket)

06B PILOT BORED SPROCKET

3/8" X 7/32" PITCH

No. of Teeth	Pitch Dia dp	Outer Dia de	Simplex (027A01--)				Duplex (027A02--)				Triplex (027A03--)			
			Hub Dia	Length Bore	Stock Bore	Type	Hub Dia	Length Bore	Stock Bore	Type	Hub Dia	Length Bore	Stock Bore	Type
			N	L	D		N	L	D		N	L	D	
8	24.89	28.00	15	22	8	A	15	22	8	A	15	32	8	A
9	27.85	31.00	16	22	8	A	18	22	8	A	18	32	8	A
10	30.82	34.00	20	22	8	A	20	22	8	A	20	32	10	A
11	33.80	37.00	22	25	8	A	22	25	10	A	22	35	10	A
12	36.80	40.00	25	25	8	A	25	25	10	A	25	35	10	A
13	39.79	43.00	28	25	10	A	28	25	10	A	28	35	10	A
14	42.80	46.30	31	25	10	A	31	25	10	A	31	35	12	A
15	45.81	49.30	34	25	10	A	34	25	10	A	34	35	12	A
16	48.82	52.30	37	28	10	A	37	30	12	A	37	35	12	A
17	51.83	55.30	40	28	10	A	40	30	12	A	40	35	12	A
18	54.85	58.30	43	28	10	A	43	30	12	A	43	35	12	A
19	57.87	61.30	45	28	10	A	46	30	12	A	46	35	12	A
20	60.89	64.30	46	28	10	A	49	30	12	A	49	35	12	A
21	63.91	68.00	48	28	12	A	52	30	12	A	52	40	14	A
22	66.93	71.00	50	28	12	A	55	30	12	A	55	40	14	A
23	69.95	73.50	52	28	12	A	58	30	12	A	58	40	14	A
24	72.97	77.00	54	28	12	A	61	30	12	A	61	40	14	A
25	76.00	80.00	57	28	12	A	64	30	12	A	64	40	14	A
26	79.02	83.00	60	28	12	A	67	30	12	A	67	40	14	A
27	82.05	86.00	60	28	12	A	70	30	12	A	70	40	14	A
28	85.07	89.00	60	28	12	A	73	30	12	A	73	40	14	A
29	88.09	92.00	60	28	12	A	76	30	12	A	76	40	14	A
30	91.12	94.70	60	30	12	A	79	30	12	A	79	40	14	A
31	94.15	98.30	65	30	14	A	80	30	16	A	80	40	16	A
32	97.17	101.30	65	30	14	A	80	30	16	A	80	40	16	A
33	100.20	104.30	65	30	14	A	80	30	16	A	80	40	16	A
34	103.23	107.30	65	30	14	A	80	30	16	A	85	40	16	A
35	106.26	110.40	65	30	14	A	80	30	16	A	85	40	16	A
36	109.29	113.43	70	30	14	A	90	30	16	A	90	40	16	A
37	112.32	116.40	70	30	14	A	90	30	16	A	90	40	16	A
38	115.35	119.50	70	30	14	A	90	30	16	A	90	40	16	A
39	118.37	122.50	70	30	14	A	90	30	16	A	90	40	16	A
40	121.40	125.50	70	30	14	A	90	30	16	A	90	40	16	A
45	136.55	140.70	70	32	19	B	80	32	19	B	90	56	24	B
57	172.91	176.90	70	32	19	B	80	32	19	B	90	56	24	B
76	230.49	234.50	70	32	19	B	80	32	19	B	100	56	24	B
95	288.08	292.50	80	40	19	B	80	32	19	B	100	56	24	B
114	345.68	350.30	80	40	20	B	95	45	20	B	100	56	24	B

Tooth Width
 B1 5.3mm
 b1 5.2mm
 B2 15.4mm
 B3 25.6mm

FINISHED BORES
 For bore and keywayed sprockets, the maximum finished bore diameter is normally hub diameter N ÷ 1.5

Type A = Steel C45
 Type B = Cast Iron GG22

Pilot Bored Sprockets

08B PILOT BORED SPROCKET

1/2" X 5/16" PITCH

No. of Teeth	Pitch Dia	Outer Dia	Simplex (027B01--)				Duplex (027B02--)				Triplex (027B03--)				Tooth Width
			Hub Dia	Length Bore	Stock Bore	Type	Hub Dia	Length Bore	Stock Bore	Type	Hub Dia	Length Bore	Stock Bore	Type	
			N	L	D		N	L	D		N	L	D		
8	33.18	37.20	20	25	10	A	20	32	10	A	20	46	10	A	B1
9	37.13	41.00	24	25	10	A	24	32	10	A	24	46	12	A	b1
10	41.10	45.20	26	25	10	A	28	32	10	A	28	46	12	A	B2
11	45.07	48.70	29	25	10	A	32	35	12	A	32	50	14	A	B3
12	49.07	53.00	33	28	10	A	35	35	12	A	35	50	14	A	
13	53.06	57.40	37	28	10	A	38	35	12	A	38	50	14	A	
14	57.07	61.80	41	28	10	A	42	35	12	A	42	50	14	A	
15	61.09	65.50	45	28	10	A	46	35	12	A	46	50	14	A	
16	65.10	69.50	50	28	12	A	50	35	14	A	50	50	16	A	
17	69.11	73.60	52	28	12	A	54	35	14	A	54	50	16	A	
18	73.14	77.80	56	28	12	A	58	35	14	A	58	50	16	A	
19	77.16	81.70	60	28	12	A	62	35	14	A	62	50	16	A	
20	81.19	85.80	64	28	12	A	66	35	14	A	66	50	16	A	
21	85.22	89.70	68	28	12	A	70	40	16	A	70	55	16	A	
22	89.24	93.80	70	28	12	A	70	40	16	A	70	55	16	A	
23	93.27	98.20	70	28	14	A	70	40	16	A	70	55	16	A	
24	97.29	101.80	70	28	14	A	75	40	16	A	75	55	16	A	
25	101.33	105.80	70	28	14	A	80	40	16	A	80	55	16	A	
26	105.36	110.00	70	30	16	A	85	40	16	A	85	55	20	A	
27	109.40	114.00	70	30	16	A	85	40	16	A	85	55	20	A	
28	113.42	118.00	70	30	16	A	90	40	16	A	90	55	20	A	
29	117.46	122.00	80	30	16	A	95	40	16	A	95	55	20	A	
30	121.50	126.10	80	30	16	A	100	40	16	A	100	55	20	A	
31	125.54	130.20	90	30	16	A	100	40	20	A	110	55	20	A	
32	129.56	134.30	90	30	16	A	100	40	20	A	110	55	20	A	
33	133.60	138.40	90	30	16	A	100	40	20	A	110	55	20	A	
34	137.64	142.60	90	30	16	A	100	40	20	A	110	55	20	A	
35	141.68	146.70	90	30	16	A	100	40	20	A	110	55	20	A	
36	145.72	151.00	90	35	16	A	100	40	20	A	120	55	25	A	
37	149.76	154.60	90	35	16	A	100	40	20	A	120	55	25	A	
38	153.80	158.60	90	35	16	A	100	40	20	A	120	55	25	A	
39	157.83	162.70	90	35	16	A	100	40	20	A	120	55	25	A	
40	161.87	166.80	90	35	16	A	100	40	20	A	120	55	25	A	
45	182.07	188.00	70	40	19	B	90	50	23	B	100	60	24	B	
57	230.54	236.40	70	40	19	B	90	50	23	B	100	60	24	B	
76	307.33	313.30	80	40	23	B	100	56	23	B	100	60	24	B	
95	384.11	390.10	80	45	23	B	100	56	23	B	120	67	24	B	
114	460.91	466.90	80	45	24	B	100	63	24	B	120	67	24	B	

Tooth Width
 B1 7.2mm
 b1 7.0mm
 B2 21.0mm
 B3 34.9mm

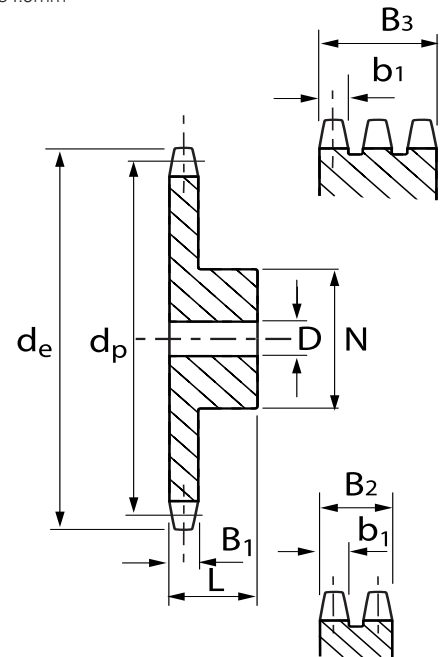

Type A = Steel C45
 Type B = Cast Iron GG22

To complete the product code insert the number of teeth required
 (027B0109 = 08B-1 1/2" pitch 9 tooth pilot bore sprocket)

10B PILOT BORED SPROCKET

5/8" X 3/8" PITCH

No. of Teeth	Pitch Dia	Outer Dia	Simplex (027C01--)				Duplex (027C02--)				Triplex (027C03--)				Tooth Width
			Hub Dia	Length Bore	Stock Bore	Type	Hub Dia	Length Bore	Stock Bore	Type	Hub Dia	Length Bore	Stock Bore	Type	
			N	L	D		N	L	D		N	L	D		
8	41.48	47.00	25	25	10	A	25	40	12	A	25	55	12	A	B1
9	46.42	52.60	30	25	10	A	30	40	12	A	30	55	12	A	b1
10	51.37	57.50	35	25	10	A	35	40	12	A	35	55	16	A	B2
11	56.34	63.00	37	30	12	A	39	40	14	A	39	55	16	A	B3
12	61.34	68.00	42	30	12	A	44	40	14	A	44	55	16	A	
13	66.32	73.00	47	30	12	A	49	40	14	A	49	55	16	A	
14	71.34	78.00	52	30	12	A	54	40	14	A	54	55	16	A	
15	76.36	83.00	57	30	12	A	59	40	14	A	59	55	16	A	
16	81.37	88.00	60	30	12	A	64	45	16	A	64	60	16	A	
17	86.39	93.00	60	30	12	A	69	45	16	A	69	60	16	A	
18	91.42	98.30	70	30	14	A	74	45	16	A	74	60	16	A	
19	96.45	103.30	70	30	14	A	79	45	16	A	79	60	16	A	
20	101.49	108.40	75	30	14	A	84	45	16	A	84	60	16	A	
21	106.52	113.40	75	30	16	A	85	45	16	A	85	60	20	A	
22	111.55	118.00	80	30	16	A	90	45	16	A	90	60	20	A	
23	116.58	123.40	80	30	16	A	95	45	16	A	95	60	20	A	
24	121.62	128.30	80	30	16	A	100	45	16	A	100	60	20	A	
25	126.66	134.00	80	30	16	A	105	45	16	A	105	60	20	A	
26	131.70	139.00	85	35	20	A	110	45	20	A	110	60	20	A	
27	136.75	144.00	85	35	20	A	110	45	20	A	110	60	20	A	
28	141.78	148.70	90	35	20	A	115	45	20	A	115	60	20	A	
29	146.83	153.80	90	35	20	A	115	45	20	A	115	60	20	A	
30	151.87	158.80	90	35	20	A	120	45	20	A	120	60	20	A	
31	156.92	163.90	95	35	20	A	120	45	20	A	120	60	20	A	
32	161.95	168.90	95	35	20	A	120	45	20	A	120	60	20	A	
33	167.00	174.50	95	35	20	A	120	45	20	A	120	60	20	A	
34	172.05	179.00	95	35	20	A	120	45	20	A	120	60	20	A	
35	177.10	184.10	95	35	20	A	120	45	20	A	120	60	20	A	
36	182.15	189.10	100	35	20	A	120	45	20	A	120	60	25	A	
37	187.20	194.20	100	35	20	A	120	45	20	A	120	60	25	A	
38	192.24	199.20	100	35	20	A	120	45	20	A	120	60	25	A	
39	197.29	204.20	100	35	20	A	120	45	20	A	120	60	25	A	
40	202.34	209.30	100	35	20	A	120	45	20	A	120	60	25	A	
45	227.58	235.00	80	40	19	B	100	50	30	B	100	60	32	B	
57	288.18	296.00	90	45	23	B	100	56	30	B	100	63	32	B	
76	384.16	392.10	90	50	23	B	100	63	30	B	110	67	35	B	
95	480.14	488.50	100	56	23	B	110	63	30	B	125	70	35	B	
114	576.13	584.10	100	56	24	B	125	70	30	B	125	80	35	B	

Tooth Width
 B1 9.1mm
 b1 9.0mm
 B2 25.5mm
 B3 42.1mm

FINISHED BORES
 For bore and keywayed sprockets, the maximum finished bore diameter is normally hub diameter N ÷ 1.5

Type A = Steel C45
 Type B = Cast Iron GG22

To complete the product code insert the number of teeth required
 (027C0109 = 10B-1 5/8" pitch 9 tooth pilot bore sprocket)

Pilot Bored Sprockets



12B PILOT BORED SPROCKETS

3/4" X 7/16" PITCH

No. of Teeth	Pitch Dia dp	Outer Dia de	Simplex (027D01--)				Duplex (027D02--)				Triplex (027D03--)			
			Hub Dia	Length Bore	Stock Bore	Type	Hub Dia	Length Bore	Stock Bore	Type	Hub Dia	Length Bore	Stock Bore	Type
			N	L	D		N	L	D		N	L	D	
8	49.78	57.60	31	30	12	A	31	45	12	A	31	65	16	A
9	55.70	62.00	37	30	12	A	37	45	12	A	37	65	16	A
10	61.64	69.00	42	30	12	A	42	45	12	A	42	65	16	A
11	67.61	75.00	46	35	14	A	47	50	16	A	47	70	20	A
12	73.61	81.50	52	35	14	A	53	50	16	A	53	70	20	A
13	79.59	87.50	58	35	14	A	59	50	16	A	59	70	20	A
14	85.61	93.60	64	35	14	A	65	50	16	A	65	70	20	A
15	91.63	99.80	70	35	14	A	71	50	16	A	71	70	20	A
16	97.65	105.50	75	35	16	A	77	50	20	A	77	70	20	A
17	103.67	111.50	80	35	16	A	83	50	20	A	83	70	20	A
18	109.71	118.00	80	35	16	A	89	50	20	A	89	70	20	A
19	115.75	124.20	80	35	16	A	95	50	20	A	95	70	20	A
20	121.78	129.70	80	35	16	A	100	50	20	A	100	70	20	A
21	127.82	136.00	90	40	20	A	100	50	20	A	100	70	20	A
22	133.86	141.80	90	40	20	A	100	50	20	A	100	70	20	A
23	139.90	149.00	90	40	20	A	110	50	20	A	110	70	20	A
24	145.94	153.90	90	40	20	A	110	50	20	A	110	70	20	A
25	152.00	160.00	90	40	20	A	120	50	20	A	120	70	20	A
26	158.04	165.90	95	40	20	A	120	50	20	A	120	70	20	A
27	164.09	172.30	95	40	20	A	120	50	20	A	120	70	20	A
28	170.13	178.00	95	40	20	A	120	50	20	A	120	70	20	A
29	176.19	184.10	95	40	20	A	120	50	20	A	120	70	20	A
30	182.25	190.50	95	40	20	A	120	50	20	A	120	70	20	A
31	188.31	196.30	95	40	20	A	120	50	20	A	130	70	25	A
32	194.35	203.30	95	40	20	A	120	50	20	A	130	70	25	A
33	200.40	209.30	95	40	20	A	120	50	20	A	130	70	25	A
34	206.46	214.60	95	40	20	A	120	50	20	A	130	70	25	A
35	212.52	221.00	95	40	20	A	120	50	20	A	130	70	25	A
36	218.58	226.80	100	40	20	A	120	50	25	A	130	70	25	A
37	224.64	232.90	100	40	20	A	120	50	25	A	130	70	25	A
38	230.69	239.80	100	40	20	A	120	50	25	A	130	70	25	A
39	236.75	245.10	100	40	20	A	120	50	25	A	130	70	25	A
40	242.81	251.30	100	40	20	A	120	50	25	A	130	70	25	A
45	273.10	282.50	100	56	24	B	110	63	30	B	140	70	30	B
57	345.81	354.00	100	56	30	B	120	63	30	B	140	70	40	B
76	460.99	469.90	100	56	30	B	135	63	30	B	160	75	40	B
95	576.17	585.10	100	65	30	B	135	70	30	B	170	82	40	B
114	691.36	700.60	100	65	30	B	135	70	45	B	170	82	50	B

Tooth Width
 B1 11.1mm
 b1 10.8mm
 B2 30.3mm
 B3 49.8mm

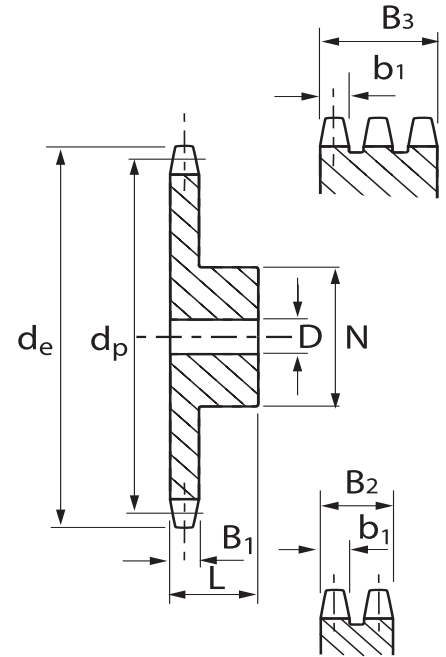

Type A = Steel C45
 Type B = Cast Iron GG22

To complete the product code insert the number of teeth required (027D0109 = 12B-1 3/4" pitch 9 tooth pilot bore sprocket)

16B PILOT BORED SPROCKETS

1" X 17.02mm PITCH

No. of Teeth	Pitch Dia dp	Outer Dia de	Simplex (027E01--)				Duplex (027E02--)				Triplex (027E03--)			
			Hub Dia	Length Bore	Stock Bore	Type	Hub Dia	Length Bore	Stock Bore	Type	Hub Dia	Length Bore	Stock Bore	Type
			N	L	D		N	L	D		N	L	D	
8	66.37	77.00	42	35	16	A	42	65	16	A	42	95	20	A
9	74.27	85.00	50	35	16	A	50	65	16	A	50	95	20	A
10	82.19	93.00	55	35	16	A	56	65	16	A	56	95	20	A
11	90.14	99.50	61	40	16	A	64	70	20	A	64	100	25	A
12	93.14	109.00	69	40	16	A	72	70	20	A	72	100	25	A
13	106.12	117.00	78	40	16	A	80	70	20	A	80	100	25	A
14	114.15	125.00	84	40	16	A	88	70	20	A	88	100	25	A
15	122.17	133.00	92	40	16	A	96	70	20	A	96	100	25	A
16	130.20	141.00	100	40	20	A	104	70	20	A	104	100	25	A
17	138.22	149.00	100	45	20	A	112	70	20	A	112	100	25	A
18	146.28	157.00	100	45	20	A	120	70	20	A	120	100	25	A
19	154.33	165.20	100	45	20	A	128	70	20	A	128	100	25	A
20	162.38	173.20	100	45	20	A	130	70	20	A	130	100	25	A
21	170.43	181.20	110	50	20	A	130	70	25	A	130	100	25	A
22	178.48	189.30	110	50	20	A	130	70	25	A	130	100	25	A
23	186.53	197.50	110	50	20	A	130	70	25	A	130	100	25	A
24	194.59	205.50	110	50	20	A	130	70	25	A	130	100	25	A
25	202.66	213.50	110	50	20	A	130	70	25	A	130	100	25	A
26	210.72	221.60	120	50	20	A	130	70	25	A	130	100	30	A
27	218.79	229.60	120	50	20	A	130	70	25	A	130	100	30	A
28	226.85	237.70	120	50	20	A	130	70	25	A	130	100	30	A
29	234.92	245.80	120	50	20	A	130	70	25	A	130	100	30	A
30	243.00	254.00	120	50	20	A	130	70	25	A	130	100	30	A
31	251.08	262.00	120	50	25	A	140	70	25	A	140	100	30	B
32	259.13	270.00	120	50	25	A	140	70	25	A	140	100	30	B
33	267.21	278.50	120	50	25	A	140	70	25	A	140	100	30	B
34	275.28	287.00	120	50	25	A	140	70	25	A	140	100	30	B
35	283.36	296.20	120	50	25	A	140	70	25	A	140	100	30	B
36	291.44	304.60	120	50	25	A	140	70	25	A	140	100	30	B
37	299.51	312.60	120	50	25	A	140	70	25	A	140	100	30	B
38	307.59	320.70	120	50	25	A	140	70	25	A	140	100	30	B
39	315.67	328.80	120	50	25	A	140	70	25	A	140	100	30	B
40	323.75	336.90	120	50	25	A	140	70	25	A	140	100	30	B
45	364.13	377.00	125	70	30	B	150	75	40	B	160	100	45	B
57	461.08	474.00	125	70	35	B	170	90	40	B	180	100	45	B
76	614.65	627.00	140	80	35	B	175	95	40	B	200	110	45	B
95	768.22	781.10	140	80	40	B	175	95	45	B	200	110	50	B
114	921.81	935.60	140	80	40	B	175	95	45	B	200	115	50	B

Tooth Width
 B1 16.2mm
 b1 15.8mm
 B2 47.7mm
 B3 79.6mm

FINISHED BORES
 For bore and keywayed sprockets, the maximum finished bore diameter is normally hub diameter N ÷ 1.5

Type A = Steel C45
 Type B = Cast Iron GG22

To complete the product code insert the number of teeth required (027E0109 = 16B-1 1" pitch 9 tooth pilot bore sprocket)

20B PILOT BORED SPROCKETS

1.1/4" X 3/4" PITCH

No. of Teeth	Pitch Dia	Outer Dia	Simplex (027F01--)				Duplex (027F02--)				Triplex (027F03--)			
			Hub Dia	Length Bore	Stock Bore	Type	Hub Dia	Length Bore	Stock Bore	Type	Hub Dia	Length Bore	Stock Bore	Type
			N	L	D		N	L	D		N	L	D	
8	82.96	98.10	53	40	20	A	53	75	20	A	53	110	20	A
9	92.84	108.00	63	40	20	A	63	75	20	A	63	110	20	A
10	102.74	117.90	70	40	20	A	70	75	20	A	70	110	20	A
11	112.68	127.80	77	45	20	A	80	80	20	A	80	115	20	A
12	122.68	137.80	88	45	20	A	90	80	20	A	90	115	20	A
13	132.65	147.80	98	45	20	A	100	80	20	A	100	115	20	A
14	142.68	157.80	108	45	20	A	110	80	20	A	110	115	20	A
15	152.72	167.90	118	45	20	A	120	80	20	A	120	115	20	A
16	162.75	177.90	120	50	20	A	120	80	25	A	120	115	25	A
17	172.78	187.90	120	50	25	A	120	80	25	A	120	115	25	A
18	182.85	198.00	120	50	25	A	120	80	25	A	120	115	25	A
19	192.91	208.10	120	50	25	A	120	80	25	A	120	115	25	A
20	202.98	218.10	120	50	25	A	120	80	25	B	120	115	25	B
21	213.04	228.20	140	55	25	A	140	80	25	B	140	115	25	B
22	223.11	238.30	140	55	25	A	140	80	25	B	140	115	25	B
23	233.17	248.30	140	55	25	A	140	80	25	B	140	115	25	B
24	243.23	258.40	140	55	25	A	140	80	25	B	140	115	25	B
25	253.33	268.50	140	55	25	A	140	80	25	B	140	115	25	B
26	263.40	278.60	150	55	25	A	150	80	25	B	150	115	25	B
27	273.49	288.60	150	55	25	A	150	80	25	B	150	115	25	B
28	283.56	298.70	150	55	25	A	150	80	25	B	150	115	25	B
29	293.65	308.80	150	55	25	A	150	80	25	B	150	115	25	B
30	303.75	318.90	150	55	25	A	150	80	25	B	150	115	25	B
31	313.85	329.00	150	55	25	A	150	80	25	B	150	115	30	B
32	323.91	339.10	150	55	25	A	150	80	25	B	150	115	30	B
33	334.01	349.20	150	55	25	A	150	80	25	B	150	115	30	B
34	344.10	359.30	150	55	25	A	150	80	25	B	150	115	30	B
35	354.20	369.40	150	55	25	A	150	80	25	B	150	115	30	B
36	364.30	379.50	150	55	25	A	150	80	30	B	150	115	30	B
37	374.39	389.50	150	55	25	A	150	80	30	B	150	115	30	B
38	384.49	399.60	150	55	25	A	150	80	30	B	150	115	30	B
39	394.59	409.70	150	55	25	B	150	80	30	B	150	115	30	B
40	404.69	419.80	150	55	25	B	150	80	30	B	150	115	30	B
57	576.35	591.50	135	80	40	B	170	100	50	B	180	130	50	B
76	768.32	783.50	140	90	50	B	180	110	50	B	200	140	50	B

Tooth Width

- B1 18.5mm
- b1 18.2mm
- B2 54.6mm
- B3 91.0mm

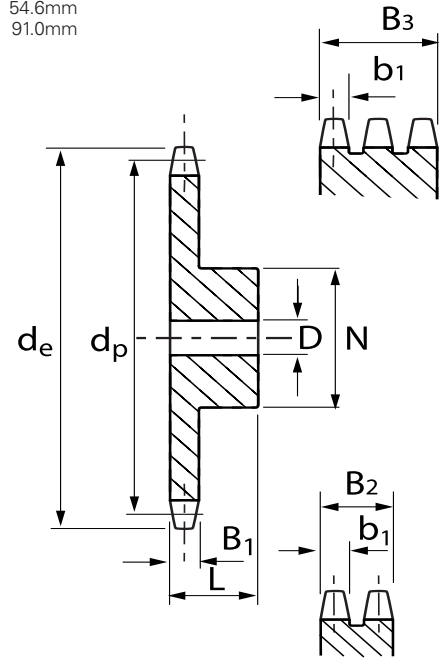

Type A = Steel C45
 Type B = Cast Iron GG22

To complete the product code insert the number of teeth required (027F0109 = 20B-1 1.1/4" pitch 9 tooth pilot bore sprocket)

FINISHED BORES

For bore and keywayed sprockets, the maximum finished bore diameter is normally hub diameter (N) / 1.5

Platewheel Sprockets

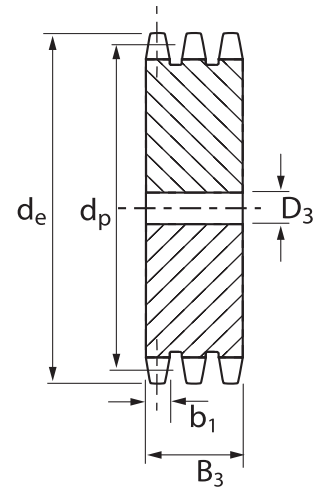
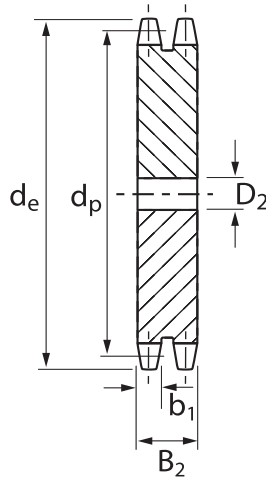
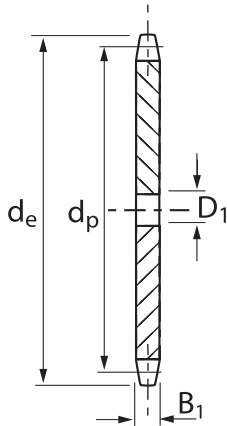

05B PLATEWHEEL 8 X 3mm PITCH
(027J00– for simplex)

Tooth Width	B ₁	2.8mm
	b ₁	2.7mm
	B ₂	8.3mm

06B PLATEWHEEL 3/8" X 7/32" PITCH
(027A00– for simplex)

Tooth Width	B ₁	5.3mm
	b ₁ <td>5.2mm</td>	5.2mm
	B ₂ <td>15.4mm</td>	15.4mm
	B ₃ <td>25.6mm</td>	25.6mm

08B PLATEWHEEL 1/2" X 5/16" PITCH
(027B00– for simplex)

Tooth Width	B ₁	7.2mm
	b ₁ <td>7.0mm</td>	7.0mm
	B ₂ <td>21.0mm</td>	21.0mm
	B ₃ <td>34.9mm</td>	34.9mm

No. of Teeth	Pitch Dia	Outer Dia	Stock Bore		
	dp	de	Simp D ₁	Dup D ₂	Trip D ₃
8	20.90	24.00	6	8	
9	23.39	26.60	6	8	
10	25.89	29.20	8	8	
11	28.39	31.70	8	8	
12	30.91	34.20	8	8	
13	33.42	36.70	8	8	
14	35.95	39.20	8	8	
15	38.48	41.70	8	8	
16	41.01	44.30	8	10	
17	43.53	46.80	8	10	
18	46.07	49.30	8	10	
19	48.61	51.90	8	10	
20	51.14	54.40	8	10	
21	53.68	57.00	8	10	
22	56.21	59.50	8	10	
23	58.75	62.00	8	10	
24	61.29	64.60	8	10	
25	63.83	67.50	8	10	
26	66.37	69.50	10	12	
27	68.91	72.20	10	12	
28	71.45	74.80	10	12	
29	73.99	77.30	10	12	
30	76.53	79.80	10	12	
31	79.08	82.40	10	12	
32	81.61	84.90	10	12	
33	84.16	87.50	10	12	
34	86.70	90.00	10	12	
35	89.25	92.50	10	12	
36	91.79	95.00	10	12	
37	94.33	97.60	10	12	
38	96.88	100.20	10	12	
39	99.42	102.70	10	12	
40	101.97	105.30	10	12	
41	104.51	107.80	12	14	
42	107.05	110.40	12	14	
43	109.60	112.90	12	14	
44	112.14	115.50	12	14	
45	114.69	118.00	12	14	
46	117.23	120.60	12	14	
47	119.77	123.10	12	14	
48	122.32	125.60	12	14	
57	145.22	148.60	14	16	
76	193.59	197.70	20	20	
95	241.96	246.10	20	20	

No. of Teeth	Pitch Dia	Outer Dia	Stock Bore		
	dp	de	Simp D ₁	Dup D ₂	Trip D ₃
8	24.89	28.00	6	8	8
9	27.85	31.00	7	8	8
10	30.82	34.00	7	8	10
11	33.80	37.00	8	10	10
12	36.80	40.00	8	10	10
13	39.79	43.00	8	10	10
14	42.80	46.30	8	10	12
15	45.81	49.30	8	10	12
16	48.82	52.30	10	12	12
17	51.83	55.30	10	12	12
18	54.85	58.30	10	12	12
19	57.87	61.30	10	12	12
20	60.89	64.30	10	12	12
21	63.91	68.00	10	12	14
22	66.93	71.00	10	12	14
23	69.95	73.50	10	12	14
24	72.97	77.00	10	12	14
25	76.00	80.00	10	12	14
26	79.02	83.00	10	12	14
27	82.05	86.00	10	12	14
28	85.07	89.00	10	12	14
29	88.09	92.00	10	12	14
30	91.12	94.70	10	12	14
31	94.15	98.30	12	14	16
32	97.17	101.30	12	14	16
33	100.20	104.30	12	14	16
34	103.23	107.30	12	14	16
35	106.26	110.40	12	14	16
36	109.29	113.40	12	14	16
37	112.32	116.40	12	14	16
38	115.35	119.50	12	14	16
39	118.37	122.50	12	14	16
40	121.40	125.50	12	14	16
41	124.43	128.50	16	16	16
42	127.46	131.60	16	16	16
43	130.49	134.60	16	16	16
44	133.52	137.60	16	16	16
45	136.55	140.70	16	16	16
46	139.58	143.70	16	16	16
47	142.61	146.70	16	16	16
48	145.64	149.70	16	16	16
57	172.91	176.90	16	16	20
76	230.49	234.90	20	20	25
95	288.08	292.50	20	20	25

No. of Teeth	Pitch Dia	Outer Dia	Stock Bore		
	dp	de	Simp D ₁	Dup D ₂	Trip D ₃
8	33.18	37.20	8	10	10
9	37.13	41.00	8	10	10
10	41.10	45.20	8	10	10
11	45.07	48.70	10	10	12
12	49.07	53.00	10	10	12
13	53.06	57.40	10	10	12
14	57.07	61.80	10	10	12
15	61.09	65.50	10	10	12
16	65.10	69.50	10	12	16
17	69.11	73.60	10	12	16
18	73.14	77.80	10	12	16
19	77.16	81.70	10	12	16
20	81.19	85.80	10	12	16
21	85.22	89.70	12	16	16
22	89.24	93.80	12	16	16
23	93.27	98.20	12	16	16
24	97.29	101.80	12	16	16
25	101.33	105.80	12	16	16
26	105.36	110.00	16	16	16
27	109.40	114.00	16	16	16
28	113.42	118.00	16	16	16
29	117.46	122.00	16	16	16
30	121.50	126.10	16	16	16
31	125.54	130.20	16	16	20
32	129.56	134.30	16	16	20
33	133.60	138.40	16	16	20
34	137.64	142.60	16	16	20
35	141.68	146.70	16	16	20
36	145.72	151.00	16	20	20
37	149.76	154.60	16	20	20
38	153.80	158.60	16	20	20
39	157.83	162.70	16	20	20
40	161.87	166.80	16	20	20
41	165.91	171.40	20	20	25
42	169.95	175.40	20	20	25
43	173.99	179.70	20	20	25
44	178.03	183.80	20	20	25
45	182.07	188.00	20	20	25
46	186.10	192.10	20	20	25
47	190.14	196.20	20	20	25
48	194.18	200.30	20	20	25
57	230.54	236.40	20	25	25
76	307.33	313.30	25	25	25
95	384.11	390.10	25	25	25

MATERIAL: Steel grade C45 To complete the product code insert the number of teeth required (027B0009 = 08B-1 1/2" pitch 9 tooth simplex platewheel)

Platewheel Sprockets

10B PLATEWHEEL 5/8" X 3/8" PITCH
(027C00– for simplex)

Tooth Width

B ₁	9.1mm
b ₁	9.0mm
B ₂	25.5mm
B ₃	42.1mm

12B PLATEWHEEL 3/4" X 7/16" PITCH
(027D00– for Simplex)

Tooth Width

B ₁	11.1mm
b ₁	10.8mm
B ₂	30.3mm
B ₃	49.8mm

16B PLATEWHEEL 1" X 17.02mm PITCH
(027E00– for Simplex)

Tooth Width

B ₁	16.2mm
b ₁	15.8mm
B ₂	47.7mm
B ₃	79.6mm

No. of Teeth	Pitch Dia	Outer Dia	Stock Bore		
	d _p	d _e	Simp D ₁	Dup D ₂	Trip D ₃
8	41.48	47.00	10	10	12
9	46.42	52.60	10	10	12
10	51.37	57.50	10	10	12
11	56.34	63.00	10	10	12
12	61.34	68.00	10	10	12
13	66.32	73.00	10	10	12
14	71.34	78.00	10	10	12
15	76.36	83.00	10	12	12
16	81.37	88.00	12	12	16
17	86.39	93.00	12	12	16
18	91.42	98.30	12	12	16
19	96.45	103.30	12	12	16
20	101.49	108.40	12	12	16
21	106.52	113.40	12	16	16
22	111.55	118.00	12	16	16
23	116.58	123.40	12	16	16
24	121.62	128.30	12	16	16
25	126.66	134.00	12	16	16
26	131.70	139.00	16	16	20
27	136.75	144.00	16	16	20
28	141.78	148.70	16	16	20
29	146.83	153.80	16	16	20
30	151.87	158.80	16	16	20
31	156.92	163.90	16	20	20
32	161.95	168.90	16	20	20
33	167.00	174.50	16	20	20
34	172.05	179.00	16	20	20
35	177.10	184.10	16	20	20
36	182.15	189.10	20	20	25
37	187.20	194.20	20	20	25
38	192.24	199.20	20	20	25
39	197.29	204.20	20	20	25
40	202.34	209.30	20	20	25
41	207.39	214.80	20	20	25
42	212.44	219.90	20	20	25
43	217.49	224.90	20	20	25
44	222.53	230.00	20	20	25
45	227.58	235.00	20	20	25
46	232.63	240.10	20	25	25
47	237.68	245.10	20	25	25
48	242.73	250.20	20	25	25
57	288.18	296.00	25	25	25
76	384.16	392.10	25	25	30
95	480.14	488.50	30	30	30

No. of Teeth	Pitch Dia	Outer Dia	Stock Bore		
	d _p	d _e	Simp D ₁	Dup D ₂	Trip D ₃
8	49.78	57.60	12	12	12
9	55.70	62.00	12	12	12
10	61.64	69.00	12	12	12
11	67.61	75.00	14	14	16
12	73.61	81.50	14	14	16
13	79.59	87.50	14	14	16
14	85.61	93.60	14	14	16
15	91.63	99.80	14	14	16
16	97.65	105.50	14	16	16
17	103.67	111.50	14	16	16
18	109.71	118.00	14	16	16
19	115.75	124.20	14	16	16
20	121.78	129.70	14	16	16
21	127.82	136.00	16	16	20
22	133.86	141.80	16	16	20
23	139.90	149.00	16	16	20
24	145.94	153.90	16	16	20
25	152.00	160.00	16	16	20
26	158.04	165.90	16	20	20
27	164.09	172.30	16	20	20
28	170.13	178.00	16	20	20
29	176.19	184.10	16	20	20
30	182.25	190.50	16	20	20
31	188.31	196.30	20	20	25
32	194.35	203.30	20	20	25
33	200.40	209.30	20	20	25
34	206.46	214.60	20	20	25
35	212.52	221.00	20	20	25
36	218.58	226.80	20	25	25
37	224.64	232.90	20	25	25
38	230.69	239.00	20	25	25
39	236.75	245.10	20	25	25
40	242.81	251.30	20	25	25
41	248.87	257.30	20	25	25
42	254.93	264.50	20	25	25
43	260.98	270.50	25	25	25
44	267.04	276.50	25	25	25
45	273.10	282.50	25	25	25
46	279.16	287.90	25	25	25
47	285.21	294.00	25	25	25
48	291.27	300.10	25	25	25
57	345.81	355.40	25	25	30
76	460.99	469.90	30	30	30
95	576.17	585.10	30	30	30

No. of Teeth	Pitch Dia	Outer Dia	Stock Bore		
	d _p	d _e	Simp D ₁	Dup D ₂	Trip D ₃
8	66.37	77.00	14	16	16
9	74.27	85.00	14	16	16
10	82.19	93.00	15	16	16
11	90.14	99.50	15	20	20
12	98.14	109.00	15	20	20
13	106.12	117.00	15	20	20
14	114.15	125.00	15	20	20
15	122.17	133.00	15	20	20
16	130.20	141.00	19	20	25
17	138.22	149.00	19	20	25
18	146.28	157.00	19	20	25
19	154.33	165.20	19	20	25
20	162.38	173.20	19	20	25
21	170.43	181.20	20	25	25
22	178.48	189.30	20	25	25
23	186.53	197.50	20	25	25
24	194.59	205.50	20	25	25
25	202.66	213.50	20	25	25
26	210.72	221.60	20	25	30
27	218.79	229.60	20	25	30
28	226.85	237.70	20	25	30
29	234.92	245.80	20	25	30
30	243.00	254.00	20	25	30
31	251.08	262.00	25	25	30
32	259.13	270.00	25	25	30
33	267.21	278.50	25	25	30
34	275.28	287.00	25	25	30
35	283.36	296.20	25	25	30
36	291.44	304.60	25	25	30
37	299.51	312.60	25	25	30
38	307.59	320.70	25	25	30
39	315.67	328.80	25	25	30
40	323.75	336.90	25	25	30
41	331.82	345.00	25	25	30
42	339.90	353.00	25	25	30
43	347.98	361.10	25	25	30
44	356.06	369.10	25	25	30
45	364.13	377.10	25	25	30
46	372.21	385.20	25	25	30
47	380.29	393.20	25	25	30
48	388.36	401.30	25	25	30
57	461.07	474.00	30	30	40
76	614.65	627.00	30	30	40
95	768.22	781.10	30	30	40

MATERIAL: Steel grade C45 To complete the product code insert the number of teeth required (027C0009 = 10B-1 5/8" pitch 9 tooth simplex platewheel)

NOTE: Platewheels for use with friction torque limiting devices may require a special surface finish.

Platewheel Sprockets



20B PLATEWHEEL 1.1/4" X 3/4" PITCH
(027F00– for Simplex)

Tooth Width

B ₁	18.5mm
b ₁	18.2mm
B ₂	54.6mm
B ₃	91.0mm

=No. of Teeth	Pitch Dia d _p	Outer Dia d _e	Stock Bore		
			Simp D ₁	Dup D ₂	Trip D ₃
8	82.96	98.10	16	20	20
9	92.84	108.00	16	20	20
10	102.74	117.90	16	20	20
11	112.68	127.80	16	20	20
12	122.68	137.80	20	20	20
13	132.65	147.80	20	20	20
14	142.68	157.80	20	20	20
15	152.72	167.90	20	20	20
16	162.75	177.90	20	25	25
17	172.78	187.90	20	25	25
18	182.85	198.00	20	25	25
19	192.91	208.10	20	25	25
20	202.98	218.10	20	25	25
21	213.04	228.20	25	25	25
22	223.11	238.30	25	25	25
23	233.17	248.30	25	25	25
24	243.23	258.40	25	25	25
25	253.33	268.50	25	25	25
26	263.40	278.60	25	25	25
27	273.49	288.60	25	25	25
28	283.56	298.70	25	25	25
29	293.65	308.80	25	25	25
30	303.75	318.90	25	25	25
31	313.85	329.00	25	25	30
32	323.91	339.10	25	25	30
33	334.01	349.20	25	25	30
34	344.10	359.30	25	25	30
35	354.20	369.40	25	25	30
36	364.30	379.50	25	30	30
37	374.39	389.50	25	30	30
38	384.49	399.60	25	30	30
39	394.59	409.70	25	30	30
40	404.69	419.80	25	30	30
41	414.77	429.90	30	30	30
42	424.86	440.00	30	30	40
43	434.96	450.10	30	30	40
44	445.06	460.20	30	30	40
45	455.17	470.30	30	30	40
46	465.25	480.40	30	30	40
47	475.35	490.50	30	30	40
48	485.45	500.60	30	30	40
57	576.35	591.50	30	30	40
76	768.32	783.50	30	30	40
95	960.25	975.20	30	30	40

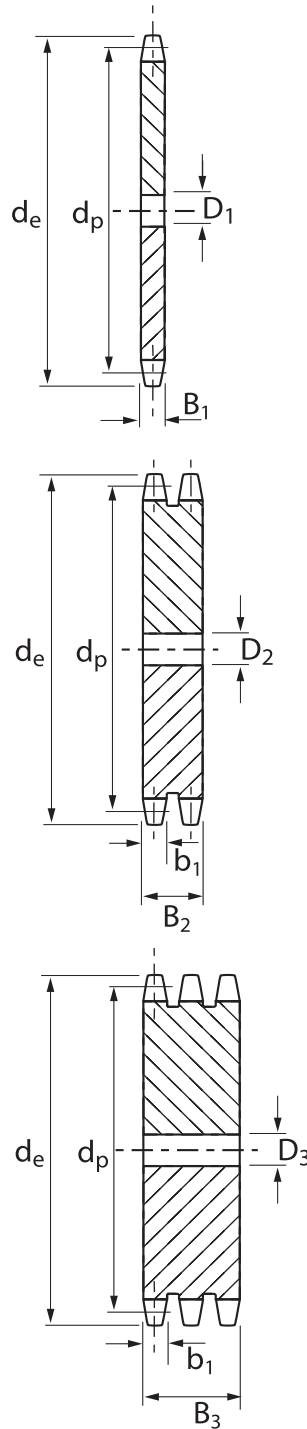

MATERIAL: Steel grade C45

To complete the product code insert the number of teeth required (027C0009 = 20B-1 1.1/4" pitch 9 tooth simplex platewheel)

NOTE: Platewheels for use with friction torque limiting devices may require a special surface finish.

INSTALLATION NOTES

Shafts must be parallel. Supporting structures must be of sufficient rigidity to maintain true alignment.

Mount sprockets as close as possible to bearings.

Check correct alignment of each sprocket by use of a straight edge.

Roller chain can be used in practically any position provided the shafts are parallel.

Where the slack strand is nearly vertical, or where torque variation causes waves or whip in the chain, an idler must be used to take up the excessive slack. The idler should preferably be near to the larger sprocket in the drive, located on the outside of the slack strand of the chain. Where layout makes this impossible it is permissible to locate the idler on the inside of the chain.

CHAIN TENSION

Chains should be fairly tight at installation with only a small amount of slack. With vertical drives the chain should be kept snug. After the first few weeks of operation, re-check chain tension and adjust if necessary.

FIXED CENTRE APPLICATIONS

An idler sprocket is generally recommended for fixed centre drives. It should be positioned on the slack side as close to the larger sprocket as feasible. The tensioning sprocket should have a minimum of three teeth engaged and be a minimum of four links away from the nearest sprocket.

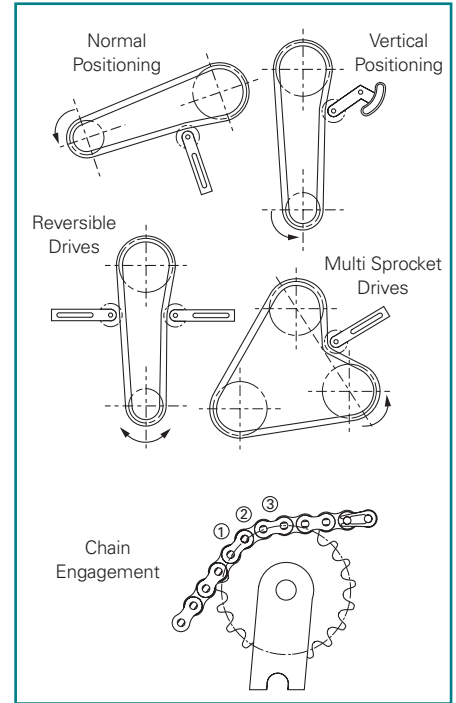

CHAIN TENSIONERS

LUBRICATION

Effective lubrication is essential in order to ensure optimum wear life from any chain.

To be effective it must form a film of lubricant between the wearing parts, (the pin and bush), of the chain. It has therefore to be of suitable viscosity and be delivered to the gap between the sideplates such that it can penetrate into the space between the pin and bush. The viscosity, amount and type of lubricant is governed by the size of chain and the operating conditions involved. Oil will only penetrate into the bearing area of the chain when the chain is slack, therefore oil should be delivered to the slack strand just after the driver sprocket.

High speed drives are especially critical. These generally require a continuous stream of lubricant applied across the full chain width in order to act as a coolant as well as lubricating the bearing area.

Three basic lubrication methods are recommended for use with Fenner roller chain.

TYPE 1 Drip Feed (for linear chain speeds up to 1 m/sec.)

Oil drops directed between the side plate gaps with a drip feed lubricator. Brush applicators may also be used, provided they are positioned to ensure that the oil is correctly delivered to the gap between the side plates. Volume and frequency should be sufficient to prevent discolouration of the lubricant in the chain joints. Any discolouration of the lubricant or of the

pin will indicate insufficient lubrication penetrating into the bearing area. Air movement, due to the motion of the drive, can disturb and mis-direct the oil drops, therefore, with due regard for safety, check the applicator while the drive is running.

TYPE 2 Oil Bath or Disc Lubricator (for linear chain speeds up to 6 m/sec.)

With oil bath lubrication the lower strand of chain runs through an oil sump. With the chain running, the oil level in the sump should immerse the chain at its lowest point. The oil level and condition of the oil should be checked periodically to ensure sufficient volume of oil is present and that it has not emulsified or become contaminated.

A disc or oil slinger may also be used. In which case the disc picks up oil from the sump and deposits it on the chain, usually through a trough. The chain operates above the oil level. The diameter of the disc should be sufficient to ensure a rim speed between 3 and 15 m/s.

TYPE 3 Pump and Sump (for high speed drives).

Oil is pumped from the sump by a circulating pump capable of delivering a constant stream of oil, evenly distributed across the full width of the chain. The oil should be supplied on the inside of the chain loop and at the lower strand, when chain speeds exceed 10 m/s.

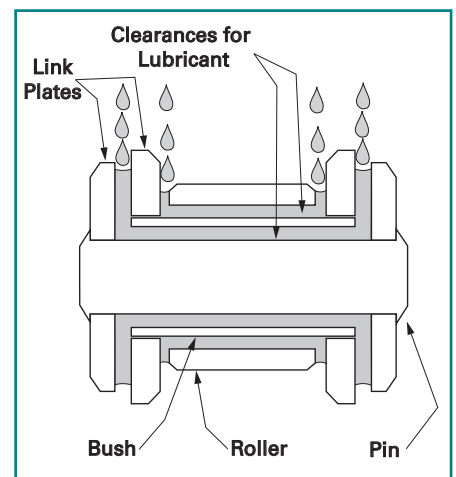

CHAIN LUBRICATION

Taper Lock® Installation Instructions



TAPER LOCK® BUSH INSTALLATION

TO INSTALL

1. After ensuring that the mating tapered surfaces, bore and shaft, are completely clean and free from oil or dirt, insert the bush into the hub so that holes line up.
2. Sparingly oil thread and point of grub screws, or thread and under head of cap screws. Place screws loosely in holes threaded in hub, shown thus ⊙ in diagram.
3. If a key is to be fitted, place it in the shaft keyway before fitting the bush. It is essential that it is a parallel key and side fitting only and has TOP CLEARANCE.
4. Clean shaft and fit hub to shaft as one unit and locate in position desired, remembering that bush will nip the shaft first and then hub will be slightly drawn on to the brush.
5. Using a hexagon wrench tighten screws gradually and alternately to torque shown in table below.
6. Hammer against large-end of bush, using a block or sleeve to prevent damage. (This will ensure that the bush is seated squarely in the bore.) Screws will now turn a little more. Repeat this alternate hammering and screw tightening once or twice to achieve maximum grip on the shaft.
7. After drive has been running under load for a short time stop and check tightness of screws.
8. Fill empty holes with grease to exclude dirt.

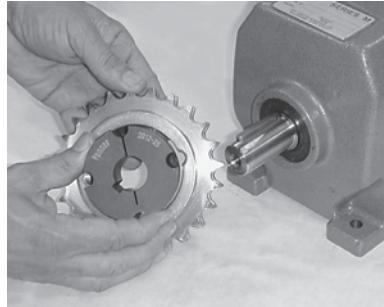

INSERT BUSH

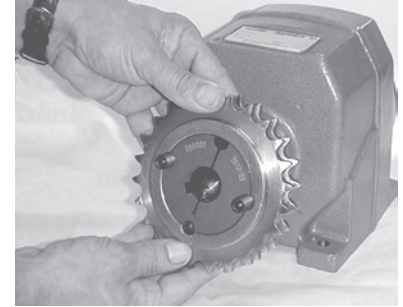

INSERT SCREWS AND LOCATE ON SHAFT

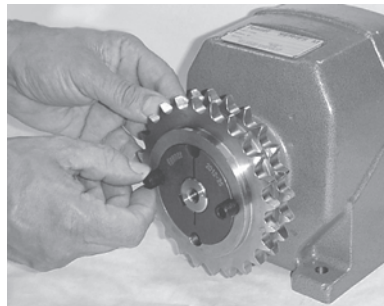

TIGHTEN SCREWS FINGER TIGHT

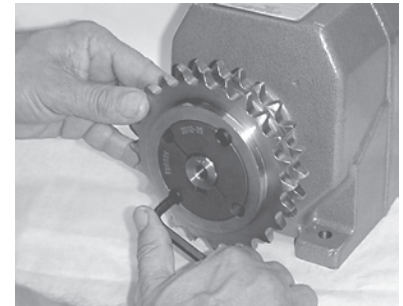

TIGHTEN SCREWS ALTERNATELY

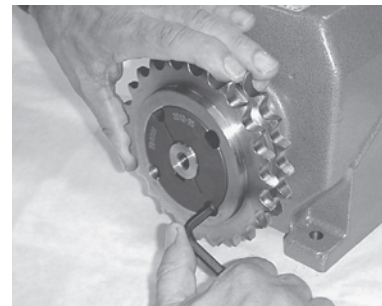

REMOVING A TAPER LOCK BUSH

TO REMOVE

1. Slacken all screws by several turns, remove one or two according to number of removal holes shown thus ● in diagram. Insert screws into removal holes after oiling thread and under head of cap screws.
2. Tighten screws alternately until bush is loosened in hub and assembly is free on the shaft.
3. Remove assembly from shaft.

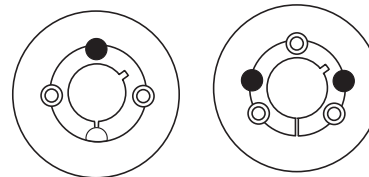

REMOVAL HOLES ●

Bush size	1008	1108	1210	1610	1615	2012	2517	3020	3030	3525	3535	4030	4040	4535	4545	5040	5050	
Screw tightening torque (Nm)	5.6	5.6	20.0	20.0	20.0	30.0	50.0	90.0	90.0	115.0	115.0	170.0	170.0	190.0	190.0	270.0	270.0	
qty	2	2	2	2	2	2	2	2	2	3	3	3	3	3	3	3	3	
Screw details	size (BSW)	1/4"	1/4"	3/8"	3/8"	3/8"	7/16"	1/2"	5/8"	5/8"	1/2"	1/2"	5/8"	5/8"	3/4"	3/4"	7/8"	7/8"
	Hex. socket size (mm)	3	3	5	5	5	6	6	8	8	10	10	12	12	14	14	14	14
Large end dia. (mm)	35.0	38.0	47.5	57.0	57.0	70.0	85.5	108.6	108.0	127.0	127.0	146.0	146.0	162.0	162.0	178.0	178.0	
Bush length (mm)	22.3	22.3	25.4	25.4	38.1	31.8	44.5	50.8	76.2	63.5	89.0	76.2	102.0	89.0	114.0	102.0	127.0	
Approx mass (kg)	0.1	0.1	0.2	0.3	0.5	0.7	1.5	2.7	3.6	3.8	5.0	5.6	7.7	7.5	10.0	11.1	14.0	

ACCESSORIES

CHAIN PULLERS

For drawing ends of a chain length together, to allow insertion of connecting links.



Catalogue Code	Model	Chain Sizes	Jaw Spread	Weight
028Z0035	35	3/8"-3/4"	50 mm	0.14 kg
028Z0050	50	1/2"-1"	85 mm	0.45 kg
028Z0080	80	1"-3"	125 mm	0.90 kg

PIN EXTRACTORS

Splitting chain to required length is simple with this easy to use tool. The pin extractor may be used with almost any size and make of roller chain.

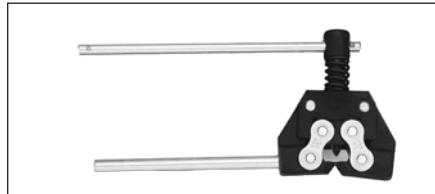

Catalogue Code	Max. Pitch
028Z0001	5/8"
028Z0002	1 1/4"
028Z0003	2"

FREEWHEEL UNITS

Size	Bore	Catalogue Code
RSJ	1 3/8"	027Z0001
NVF	2"	027Z0000
1/2" x 5/16" x 19T	1 3/8"	027Z0019
1/2" x 5/16" x 19T	1 3/8"	027Z0020
1/2" x 3/16" x 19T	1 5/8"	027Z0022
1/2" x 3/16" x 19T	2"	027Z0024

SHEARGUARD CLUTCH

The Shearguard clutch uses wedge pins for torque control, to give a simple, accurate and reliable drive overload protection. An added advantage is that the wedge pins are bolted in position and cannot fall into machinery when sheared by overload. The clutch is designed to accommodate standard platewheels for fast delivery chain drive protection.

TORQUE LIMITER

The Torque Limiter utilises spring loaded friction surfaces to limit the torque transmitted in a drive system. Protection against shock loads is achieved by a pre-set force.

When torque demand exceeds this pre-set value the unit slips, automatically re-engaging when overload torque has passed with no re-setting required.

The four sizes of Torque limiters available are designed to use a range of specially surface ground platewheels.

We recommend and offer from stock specially ground platewheels for use with all Torque Limiters.

CHAIN LUBRICANTS

Recommended lubricant is a penetrating non-mineral oil which lubricates the chain pins and frees seized chain. It forms a dry film which will not attract dust and dirt, and is also non-drip.

High temperature lubricant is also available.



Improved Performance, Longer Life.

The new Fenner Drive Alignment Laser is the perfect tool for pulley and sprocket alignment. Applied magnetically in just a few seconds, the laser line projects onto targets, allowing rapid adjustment to perfect alignment. It could not be simpler!

- Reduces wear on belts and pulleys
- Increases drive efficiency for larger energy savings
- Quick and easy to use, producing more accurate results than other methods
- Shows parallel and angular misalignment
- Suitable for both vertical & horizontal mounted machines



www.fptgroup.com

Order yours today: Product Code: 230L0000