

Rightangle

Gears

Cat.: CT-VFM-BS-HM010

Worm gearboxes

Riduttori a vite senza fine

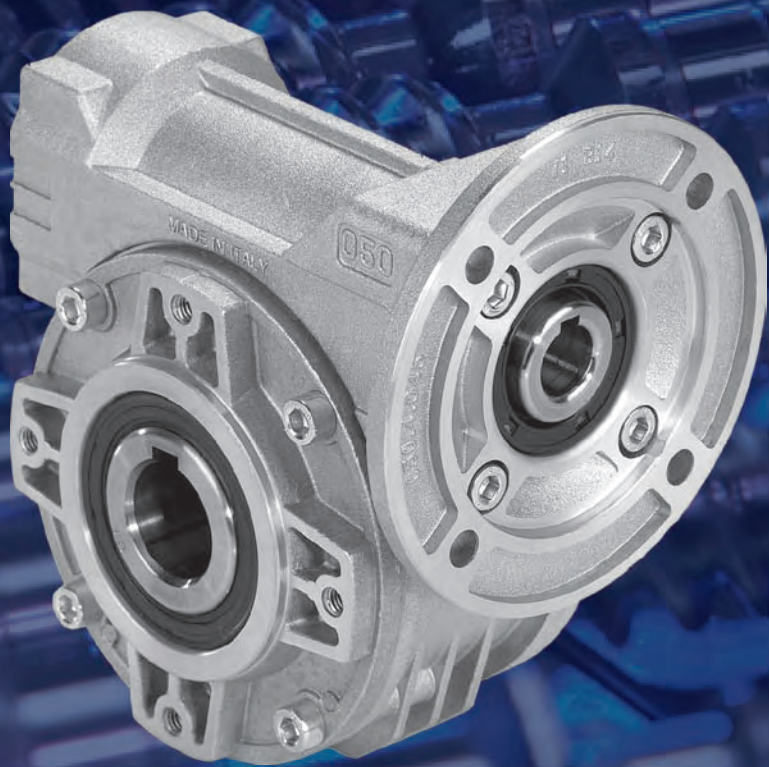

Made in Italy

HYDRO · MEC

Worm gearboxes type 030 ÷ 110

A modular and compact product

Single-piece aluminum alloy housing

Is vacuum impregnated (MIL-STD 276) for protection and sealing. No secondary finish required but readily accepts paint. Combines light weight with high tensile strength. Precision machined for alignment of bearings and gearing.

Single piece alloy steel input shaft and worm shaft.

High helix angle worm is case-hardened (Rc 58-60), ground, teeth are profiled and radiused, for noise reduction and enhanced efficiency.

Flange

Fully modular to IEC and compact integrated motor. NEMA C flange.

Oversized bearings

Support positively-retained, high speed shaft for higher shock load capacity - ideal for frequent starting and reversing application. Premium, Nitrile® high temperature seals each end.

Premium, high temperature

Nitrile® output seals

Bronze alloy worm gears.

Is centrifugally cast onto an iron hub for maximum strength and superior life.

Standard hollow output shaft mounting

Reduces total drive envelope size, weight and cost. Single and double solid output shaft is available.

Impregnated and machined bearing caps

With exterior machined surfaces enable a variety of mounting accessories. Extra-deep thread engagement provided for greater support strength. Zinc plated hardware.

Oversize bearing

For radial load capability and maximum hollow output shaft diameter.

Vent Free Design.

No breather or vents to leak! Factory lubricated for life with synthetic, semi-fluid gear lubricant with an operating range of -15°C to 130°C.

oil free



vent free



World wide sales network.

On page / A pagina / Auf Seite / En la página



Types / Tipi /
Arten / Tipos →

2-5	2-7	2-9	2-11	2-13	2-15	2-17
030 20Nm	045 39Nm	050 69Nm	063 140Nm	63A 180Nm	085 330Nm	110 620Nm

On page / A pagina / Auf Seite / En la página

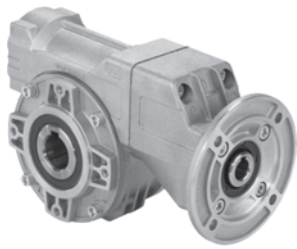

Types / Tipi /
Arten / Tipos →

2-19	2-21	2-23	2-25	2-27	2-29
P45 50Nm	P50 80Nm	P63 170Nm	P6A 198Nm	P85 400Nm	P10 730Nm

On page / A pagina / Auf Seite / En la página

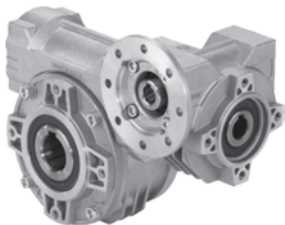

Types / Tipi /
Arten / Tipos →

2-31	2-33	2-35	2-37	2-39	2-41	2-43	2-45	2-47
303 30Nm	453 60Nm	503 95Nm	633 200Nm	634 230Nm	6A3 252Nm	6A4 264Nm	854 450Nm	115 850Nm

For : / Per : / Für : / Para :

Selection guide - fs
Guida alla selezione

Mounting pos. - Lubrication
Pos. di montaggio - lubrificazione

2 - 6 poles selection
Selezione 2 - 6 poli

Radial - axial loads
Carichi radiali e assiali

Reversibility
Reversibilità

Thermal limit
Limite termico

Atex certification
Certificazione Atex

Accessories
Accessori

Download 3D drawings
Download disegni 3D

Interchangeability
Intercambiabilità

Installation and maintenance
Installazione, uso e manutenzione

Spare parts list
Liste parti di ricambio

Use our web database to
get detailed informations,
always updated on
each type/size.

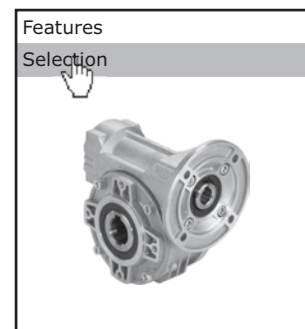

Type - Tipo - Typ - Tipo

Size - Grandezza
Größe - Tomaño

Mounting - Montaggio - Montage - Tipo de montaje

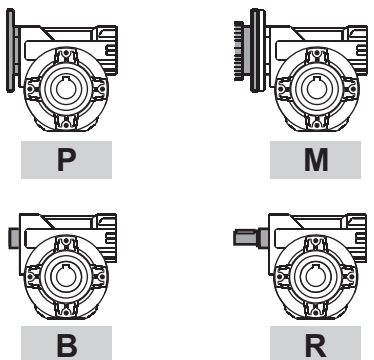
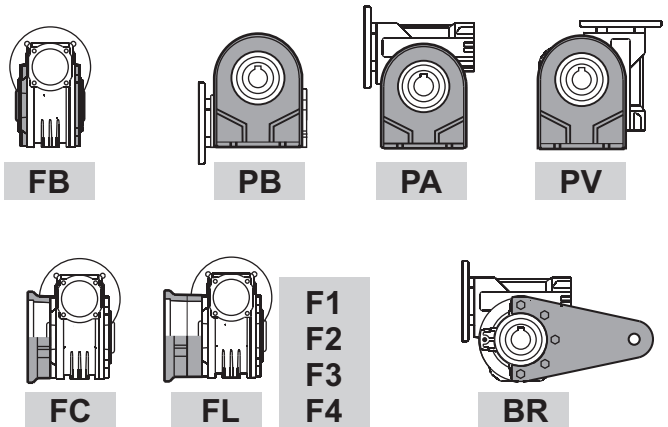
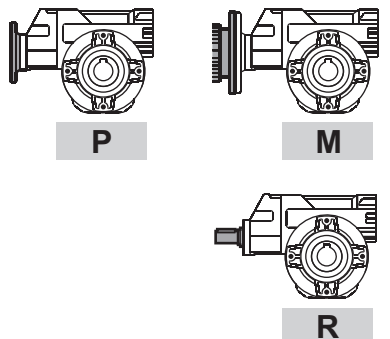
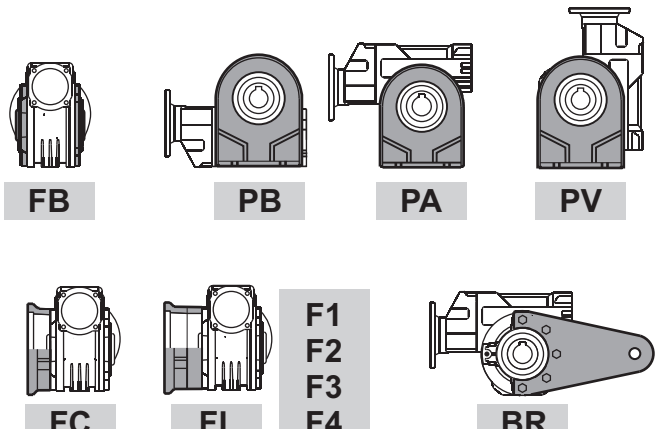
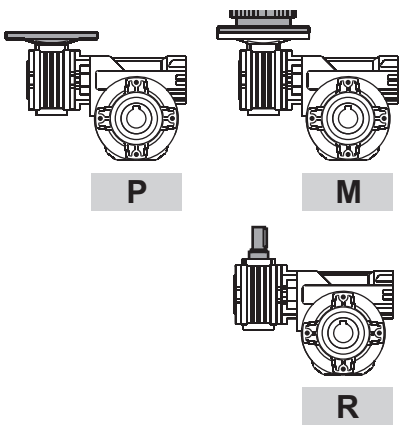
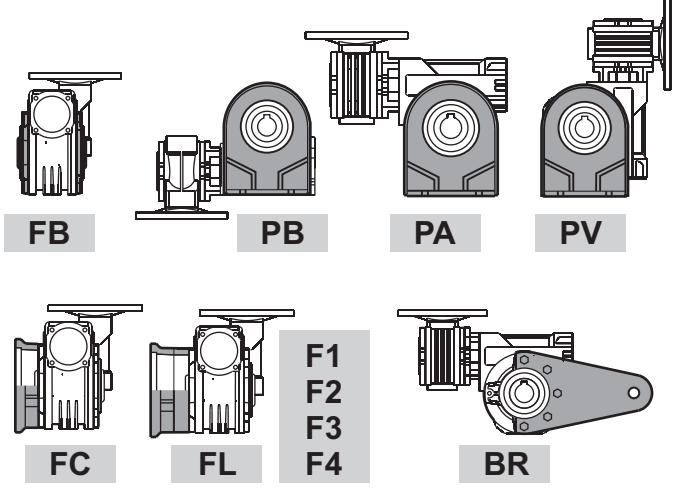
P	045	PA
<p>Worm gearboxes Riduttori a vite senza fine Schneckengetriebe Reductores de corona sin fin</p>  <p>P M B R</p>	<p>030 045 050 063 63A 085 110</p>	 <p>FB PB PA PV FC FL F1 F2 F3 F4 BR</p>
<p>Worm gearboxes with primary reduction Riduttori a vite senza fine con precoppia Schneckengetriebe mit stirnradstufe am Eintrieb Reductores corona sin fin con prerreductora de engranajes</p>  <p>P M R</p>	<p>P45 P50 P63 P6A P85 P10</p>	 <p>FB PB PA PV FC FL F1 F2 F3 F4 BR</p>
<p>Combined worm gearboxes Riduttori a vite senza fine combinati Schneckengetriebekombinationen Reductores combinados corona sin fin</p>  <p>P M R</p>	<p>303 503 633 634 6A3 6A4 854 115</p>	 <p>FB PB PA PV FC FL F1 F2 F3 F4 BR</p>

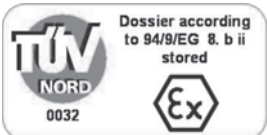





A richiesta possiamo fornire i nostri prodotti secondo le normative ATEX

On request we can deliver our products according to the ATEX

Auf Anfrage können wir unsere Produkte den Richtlinien ATEX entsprechend liefern

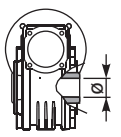
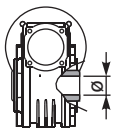
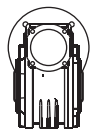
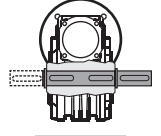
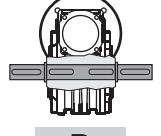
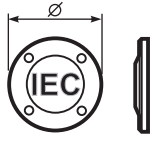
A pedido, se pueden enviar nuestros productos de acuerdo con las normas ATEX.

CODIFICA / HOW TO ORDER / TYPENBEZEICHNUNGEN / CODIFICACIÓN

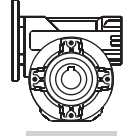
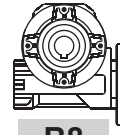
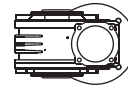
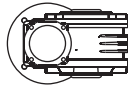
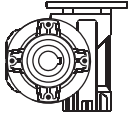
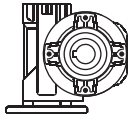
Ratio - Rapporto Untersetzung Relación	Hub - Mozzo corona Hohlwelle Nucleo corona	Output shaft Albero lento Abtriebswelle Eje solida	Motor size Grandezza motore Motor Größe Tamaño motor	Terminal box position Posizione morsettiara Klemmkastenlage Posición caja de bornes	Mounting position Posizione montaggio Einbaulage Position de montage	Reduced Input bore Foro entrata ridotto	Mountin position Esecuzione montaggio Einbaulage Posición de montaje
10	C	Ø	Q	B	B3	-	---
<p>See technical data table</p> <p>Vedi tabelle dati tecnici.</p> <p>Technisches Datenblatt beachten.</p> <p>Ver tabla datos técnicos</p>	 <p>C</p> <p>STANDARD</p> <p>030 ⇨ ø14 045 ⇨ ø18 050 ⇨ ø25 063 ⇨ ø25 63A ⇨ ø28 085 ⇨ ø35 110 ⇨ ø42</p> <p>I</p> <p>Stainless steel hub</p> <p>Mozzo in acciaio inox</p> <p>Special series Serie Speciale:</p> <p>S</p> <p>045 ⇨ ø19 050 ⇨ ø24</p> <p>X</p> <p>Mozzo in acciaio inox</p> <p>Stainless steel hub</p>  <p>U</p> <p>INCH</p> <p>045 ⇨ ø0.750" 050 ⇨ ø1.000" 063 ⇨ ø1.125" 085 ⇨ ø1.500"</p>	 <p>Ø</p>  <p>S</p>  <p>D</p>	 <p>M</p> <p>without flange Senza flangia</p> <p>B5</p> <p>A=56 (ø120) B=63 (ø140) C=71 (ø160) D=80 (ø200) E=90 (ø200) F=100+112 (ø250)</p> <p>B14</p> <p>O=56 (ø80) P=63 (ø90) Q=71 (ø105) R=80 (ø120) T=90 (ø140) U=100+112 (ø160)</p> <p>0=Type R</p> <p>Reduced Fl.</p> <p>1=56B5/ø11 2=63B5/ø14 3=71B5/ø19 4=71B5/ø24 5=90B5/ø28 6=100B5/ø38 7=132B5/ø42 8=80B14/ø11 9=100B5/ø24</p>	 <p>A</p>  <p>B</p> <p>STANDARD</p>  <p>C</p>  <p>D</p>	 <p>B3</p>  <p>B8</p>  <p>B6</p>  <p>B7</p>  <p>V5</p>  <p>V6</p>	<p>-</p> <p>Nothing indication standard bore</p> <p>Nessuna indicazione foro standard</p> <p>P</p> <p>Input bore reduced one size</p> <p>Foro entrata ridotto di una misura</p> <p>Ex. Input Flange 71 B14 Standard ø14 Reduced ø11</p> <p>Q</p> <p>Input bore reduced two sizes</p> <p>Due grandezze ridotte foro entrata</p> <p>Ex. Input Flange 71 B14 Standard ø14 Reduced ø9</p>	<p>Only for combined units See technical data table</p> <p>Solo per i riduttori combinati Vedi tabelle dati tecnici.</p> <p>Ausführungen für Getriebekombinationen it.</p> <p>Sólo para combinados ver tabla datos técnicos</p>

REQUIRED POWER / POTENZA RICHIESTA / ERFORDERLICHE LEISTUNG / POTENCIA NECESARIA

Lifting / sollevamento / hubantriebe / elevación

$$P \text{ [KW]} = \frac{M \text{ [Kg]} \cdot g \text{ [9.81]} \cdot v \text{ [m / s]}}{1000}$$

Rotation / rotazione / drehung / rotation

$$P \text{ [KW]} = \frac{M \text{ [Nm]} \cdot n \text{ [rpm]}}{9550}$$

Linear movement / traslazione / linearbewegung / translacion

$$P \text{ [KW]} = \frac{F \text{ [N]} \cdot v \text{ [m / s]}}{1000}$$

TORQUE / COPPIA / DREHMOMENT / PAR

$$M \text{ [Nm]} = \frac{9550 \cdot P \text{ [KW]}}{n \text{ [rpm]}}$$

$$M \text{ [lb in]} = \frac{63030 \cdot P \text{ [HP]}}{n \text{ [rpm]}}$$

RADIAL LOADS / CARICHI RADIALI / RADIALE - UND AXIALLASTEN / CARGA RADIAL Y AXIAL

- Radial load generated by external transmissions keyed onto input and/or output shafts.
- Forza radiale generata da organi di trasmissione calettati sugli alberi di ingresso e/o uscita.
- Belastungen der Antriebs- bzw. Abtriebswellen durch von aussen eingebrachte Radiallasten.
- Cargas radiales, generada por transmisiones externas, aplicadas sobre los ejes de entrada y/o salida

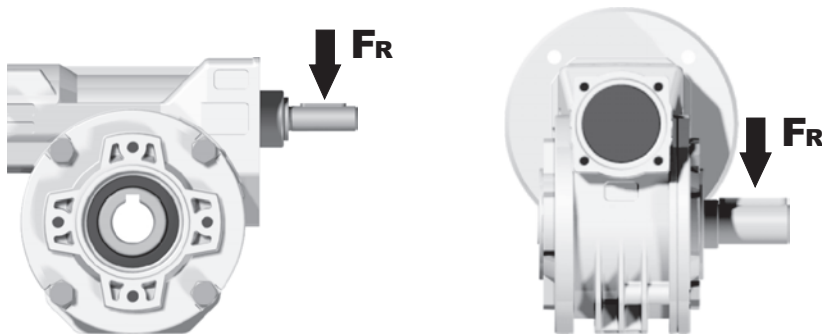

	$F_R \text{ [N]} = \frac{M \text{ [Nm]} \cdot 2000}{d \text{ [mm]}} \cdot f_k$	$F_R \text{ [N]} = \frac{M \text{ [lb in]} \cdot 8.9}{d \text{ [in]}} \cdot f_k$
M	Output torque / Momento torcente / Abtriebsdrehmoment / Par torsion	
d	Diam. of driving element / Diametro primitivo / Durchmesser der Abtriebseinheit / Diámetro primitivo	
f_k	Factor / Coefficiente di trasformazione / Faktor / Coefficiente de transmisión 1.15 Gearwheels / Ingranaggi / Zahnrad / Engranaje 1.25 Chain sprochets / Catena / Antriebskette / Cadena 1.75 Narrow v-belt pulley / Cinghia Trapezoidale / Keilriemen / Correa trapezoidal 2.50 Flat-belt pulley / Cinghia piatta / Flachzahnriem. / Correa plana	

- If your application requires higher radial loads, contact our technical office. Higher load may be possible.
- Nel caso la vostra applicazione richieda carichi radiali superiori consultare il nostro ufficio tecnico, valori maggiori possono essere accettati.
- Wenn Ihre Anwendung höhere Radialbelastungen erfordert, so wenden Sie sich bitte an unser technischen Büro.
- En el caso en que una aplicación exija una carga radial superior a la especificada en el catálogo, consultar a nuestra oficinas técnica.

How to select a gearbox / Come selezionare un riduttore
Wie wählt man ein Getriebe / Cómo seleccionar un reductor

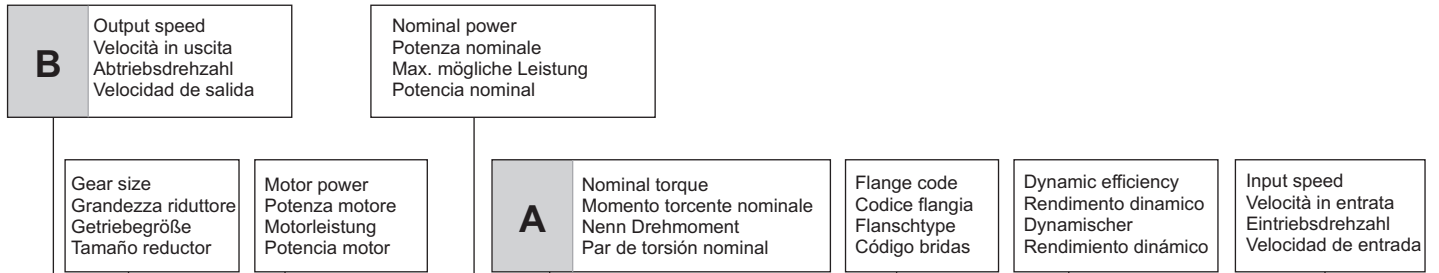

045 Rightangle - Gear **39Nm** Rating - Alluminum WORM GEARBOXES 

QUICK SELECTION / Selezione veloce input speed (n₁) = 1400 min⁻¹



Output Speed n ₂ [min ⁻¹]	Ratio i	Motor power P _{1M} [kW]	Output torque M _{2M} [Nm]	Service factor f.s.	Nominal power P _{1R} [kW]	Nominal torque M _{2R} [Nm]	Available B5 motor flanges		Available B14 motor flanges			Dynamic efficiency RD	Tooth Module Mn	Ratios code
							B	C	O	P	Q			
200	7	0.37	14	2.1	0.76	29	B		B-C	B-C		80	2.2	01
140	10	0.37	20	1.5	0.54	29	B		B-C	B-C		79	2.2	02
100	14	0.37	27	1.1	0.39	29	B		B-C	B-C		77	2.4	03



fs

Type of load and starts per hour Tipo di carico e avviamenti per ora		Oper. hours per day Ore di funz. giorn.		
		<2 h	2 - 8 h	8 - 16 h
Continuous or intermittent appl. with start / hour Applicazione cont. o interm. con n.ro operazioni/ora	Uniform / Uniforme	0.9	1	1.25
	Moderate / Moderato	1	1.25	1.5
	Heavy / Forte	1.25	1.5	1.75
Intermittent application with start / hour Applicazione intermittente con n.ro operazioni/ora	Uniform / Uniforme	1.25	1.5	1.75
	Moderate / Moderato	1.5	1.75	2
	Heavy / Forte	1.75	2	2.25

D Motor flange available
Flange disponibili
Erhältliche Motorflansche
Bridas disponibles

B)	Mounting with reduction ring Montaggio con boccia di riduzione Reduzierhülsen Montaje con casquillo de reducción	
C)	Motor flangeholes position/terminal box position Posizione fori flangia/basetta motore Bohrungsposition am Motorflansch/-sockel Posición agujeros brida / base motor	
B)	Available without reduction bushes Disponibile anche senza boccia Auch ohne Reduzierbuchse verfügbar Disponible tambien sin casquillo	

A	Select required torque (according to service factor)	Seleziona la coppia desiderata (comprensiva del fattore di servizio)	Max. Drehmoment in Bezug zum Betriebsfaktor	Seleccionar el par deseado (incluyendo el factor de servicio)
B	Select output speed	Seleziona la velocità in uscita	Ausgewählte Abtriebsdrehzahl	Seleccionar la velocidad de salida
C	On the same line of selected geared motor, you can find the gear ratio	Sulla riga corrispondente alla motorizzazione prescelta si può rilevare il rapporto di riduzione	Auf der gleichen Linie wie die ausgewählte Motorleistung steht auch die Getriebeuntersetzung	En la línea correspondiente al motor preseleccionado es posible encontrar la relación de reducción
D	Select motor flange available (if requested)	Scegli la flangia disponibile (se richiesta)	Erhältliche Motorflansche (auf Anfrage)	Seleccionar la brida disponible (sobre pedido)



QUICK SELECTION / Selezione veloce

input speed (n_1) = 1400 min⁻¹

Output Speed n_2 [min ⁻¹]	Ratio i	Motor power P_{1M} [kW]	Output torque M_{2M} [Nm]	Service factor f.s.	Nominal power P_{1R} [kW]	Nominal torque M_{2R} [Nm]	Available B5 motor flanges		Available B14 motor flanges		Dynamic efficiency RD	Tooth Module Mn [mm]	 Ratios code
							A	B	O	P			
							56	63	56	63			
280	5	0.18	5	3.2	0.57	16	B		B-C		82	1.26	01
200	7	0.18	7	2.3	0.42	16	B		B-C		80	1.44	02
140	10	0.18	10	1.7	0.30	16	B		B-C		78	1.44	03
93	15	0.18	13	1.3	0.24	18	B		B-C		73	1.44	04
70	20	0.18	17	1.0	0.19	18	B		B-C		70	1.09	05
47	30	0.12	15	1.3	0.16	20	B		B-C		62	1.44	06
35	40	0.12	19	1.0	0.12	19	B		B-C		57	1.09	07
23	61	0.09	19	1.0	0.09	19	B		B-C		50	0.72	08
17.5	80	0.09	16	1.0	0.06	15	B		B-C		48	0.56	09

A Motor Flanges Available
Flange Motore Disponibili

B Supplied with Reduction Bushing
Fornito con Bussola di Riduzione

B Available on Request without reduction bushing
Disponibile a Richiesta senza Bussola di Riduzione

C Motor Flange Holes Position
Posizione Fori Flangia Motore

EN Unit 030 is supplied with synthetic oil, providing "long life" lubrication. For mounting position V5-V6 please contact us. See table 1 for lubrication and recommended quantity. In table 2 please see possible radial loads and axial loads on the gearbox. For complete documentation please visit our web site.

I Il riduttore tipo 030 viene fornito lubrificato a vita con olio sintetico. Per posizioni V5-V6 contattare il ns. servizio tecnico. Vedi tab.1 per oli e quantità consigliati. In tab.2 sono presenti i carichi radiali e assiali applicabili al riduttore. Per la documentazione completa consulta il nostro sito.

D Für die Lebensdauerschmierung ist das Getriebe der Größe 030 mit synthetischem Öl befüllt. Bei Einbaulage V5 oder V6 bitten wir um Rücksprache. In Tabelle 1 ist die Schmiermenge und das empfohlene Schmiermittel angegeben. In Tabelle 2 sind die zulässigen Radial- und Axialbelastungen des Getriebes aufgeführt. Die komplette Dokumentation, Wartungs- und Inbetriebnahmeanleitungen finden Sie unter.

E El reductor tamaño 030 se suministra, lubricado de por vida con aceite sintético. Para las posiciones V5 y V6 contactar con nuestro servicio técnico. Ver tabla 1, para cantidades y aceites recomendados. En la tabla 2, se encuentran las cargas radiales y axiales admitidas por el reductor. Para documentación completa, consultar nuestra Web.

LUBRICATION 030 Oil Quantity 0.03 Lt.

AGIP	KLUBER	SHELL	MOBIL
Telium VSF 320	Syntheso D220 EP	Tivela Oil WB	Glygoyl 30 SHC 630

tab. 1

RADIAL AND AXIAL LOADS

Output shaft

Albero di uscita

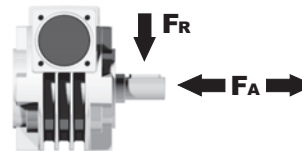

n_2 [min ⁻¹]	FA [N]	FR [N]
200	120	600
150	140	700
100	160	800
75	180	900
50	200	1000
25	250	1250
15	280	1400

Input shaft

albero in entrata

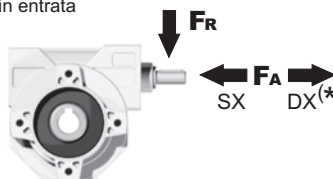

n_1 [min ⁻¹]	FA [N]	FR [N]
1400	20	100

***Strong axial loads in the DX direction are not allowed.**
Non sono consentiti forti carichi assiali con direzione DX

tab. 2

SELECT THIS TYPE AND THIS SPECIFIC SIZE ON THE WEB PAGES TO GET COMPLETE TECHNICAL DATA.
Selezionare tipo e gandezza specifica nel sito web per la documentazione completa.

P030FB... Basic wormbox
Riduttore base

Wormbox weight
peso riduttore **1.05 kg**

M. flanges	Kit code	øF	A
56B5	K030.4.041	120	61.5
63B5	K030.4.042	140	62.5
56B14	K030.4.046	80	61.5
63B14	K030.4.045	90	62.5

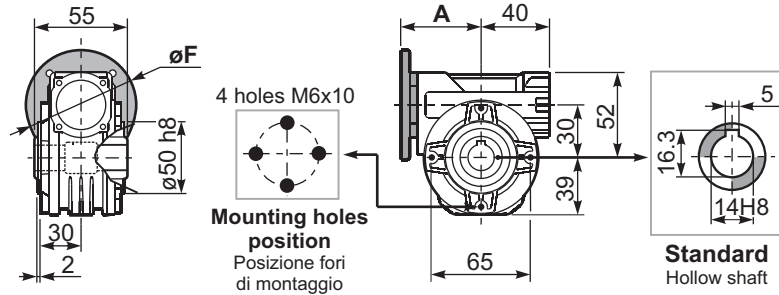

P030PA... Feet
Piedini

P030PB... Feet
Piedini

P030PV... Feet
Piedini

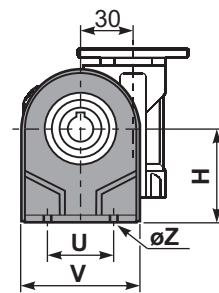
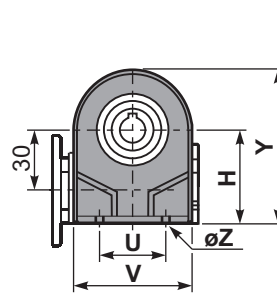
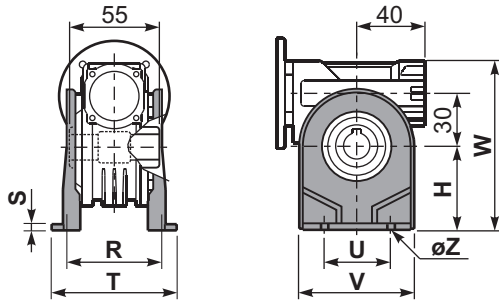

	H	R	S	T	U	V	Y	W	øZ	kit code
type B	55	66	3	87	50	78	94	107	ø6.5	K030.9.022
type S	52	66	3	87	52	90	91	104	ø6.5	KS030.9.023

P030FC... Output flange
Flangia uscita

P030BR... Reaction arm
Braccio di reazione

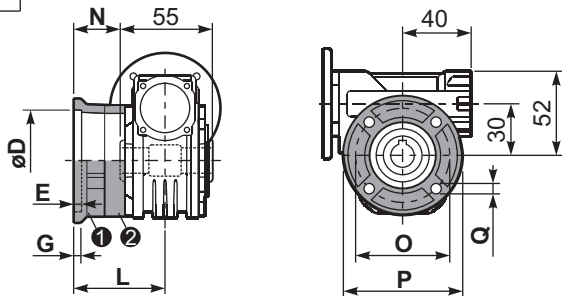

type B	øD	E	G	L	N	O	P	Q	kit code
FC	50 ^{+0.15} / _{+0.05}	6	6	50.5	23	68	80	7	① K030.9.010 ② -
FL	60 ^{+0.15} / _{+0.05}	6	6	55.5	28	87	110	8.5	① K045.9.010 ② -

type S	øD	E	G	L	N	O	P	Q	kit code
F1	40 ^{+0.15} / _{+0.10}	3.5	5.5	49	21.5	56	80	6.5	① KS030.9.012 ② -

P030.....S... Single Shaft
Albero lento semplice

P030.....D... Double Shaft
Albero lento bisp.

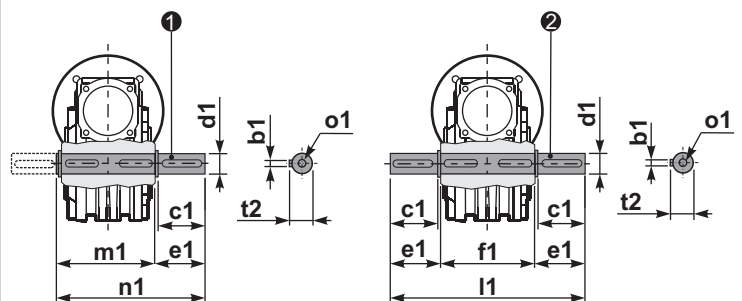

① kit cod. K030.5.028 type B ② kit cod. K030.5.029 type B

R030FB... Input shaft
Albero in entrata

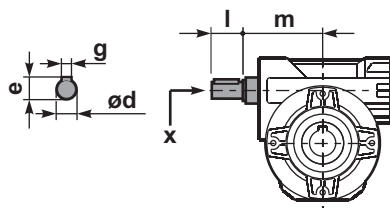

	ød	e	g	l	m	x	kit code
type B	9 h6	10.2	3	20	58	-	K030.5.006 PAM63
type S	-	-	-	-	-	-	-

	b1	c1	d1	e1	f1	l1	m1	n1	t2	o1
type B	5	25	14 ^{-0.005} / _{-0.020}	35.5	55	126	59	94.5	15.8	M5x14
type S	-	-	-	-	-	-	-	-	-	-



QUICK SELECTION / Selezione veloce							input speed (n ₁) = 1400 min ⁻¹							
Output Speed n ₂ [min ⁻¹]	Ratio i	Motor power P _{1M} [kW]	Output torque M _{2M} [Nm]	Service factor f.s.	Nominal power P _{1R} [kW]	Nominal torque M _{2R} [Nm]	Available B5 motor flanges		Available B14 motor flanges			Dynamic efficiency RD	Tooth Module Mn [mm]	Ratios code
							B	C	O	P	Q			
200	7	0.37	14	2.1	0.76	29	B		B-C	B-C		80	2.2	01
140	10	0.37	20	1.5	0.54	29	B		B-C	B-C		79	2.2	02
100	14	0.37	27	1.1	0.39	29	B		B-C	B-C		77	2.4	03
67	21	0.37	36	1.1	0.41	39	B		B-C	B-C		67	1.6	04
50	28	0.25	31	1.3	0.31	39	B		B-C	B-C		65	2.5	05
38	37	0.25	40	1.0	0.25	39	B		B-C	B-C		63	1.8	06
30	46	0.25	46	0.8	0.21	39	B		B-C	B-C		59	1.5	07
23	60	0.18	41	0.9	0.17	39	B		B-C	B-C		56	1.2	08
20	70	0.12	31	0.9	0.11	29	B		B-C	B-C		54	1.0	09
13.7	102	0.09*	28	<0.8	0.08	28	B		B-C	B-C		49	0.72	10

 Motor Flanges Available Flange Motore Disponibili
 B) Supplied with Reduction Bushing Fornito con Bussola di Riduzione
 B) Available on Request without reduction bushing Disponibile a Richiesta senza Bussola di Riduzione
 C) Motor Flange Holes Position Posizione Fori Flangia Motore

* Power higher than the maximum one which can be supported by the gearbox. Select according to the torque M_{2R}
 Potenza superiore a quella massima sopportabile dal riduttore. Selezionare in base al momento torcente M_{2R}

EN Unit 045 is supplied with synthetic oil, providing "long life" lubrication. For mounting position V5-V6 please contact us. See table 1 for lubrication and recommended quantity. In table 2 please see possible radial loads and axial loads on the gearbox. For complete documentation please visit our web site.

I Il riduttore tipo 045 viene fornito lubrificato a vita con olio sintetico. Per posizioni V5-V6 contattare il ns. servizio tecnico. Vedi tab.1 per oli e quantità consigliati. In tab.2 sono presenti i carichi radiali e assiali applicabili al riduttore. Per la documentazione completa consulta il nostro sito.

D Für die Lebensdauerschmierung ist das Getriebe der Größe 045 mit synthetischem Öl befüllt. Bei Einbaulage V5 oder V6 bitten wir um Rücksprache. In Tabelle 1 ist die Schmiermenge und das empfohlene Schmiermittel angegeben. In Tabelle 2 sind die zulässigen Radial- und Axialbelastungen des Getriebes aufgeführt. Die komplette Dokumentation, Wartungs- und Inbetriebnahmeanleitungen finden Sie unter.

E El reductor tamaño 045 se suministra, lubricado de por vida con aceite sintético. Para las posiciones V5 y V6 contactar con nuestro servicio técnico. Ver tabla 1, para cantidades y aceites recomendados. En la tabla 2, se encuentran las cargas radiales y axiales admitidas por el reductor. Para documentación completa, consultar nuestra Web.

• LUBRICATION 045 Oil Quantity 0.09 Lt.

AGIP	KLUBER	SHELL	MOBIL
Telium VSF 320	Syntheso D220 EP	Tivela Oil WB	Glygoyl 30 SHC 630

tab. 1

• RADIAL AND AXIAL LOADS

Output shaft
Albero di uscita

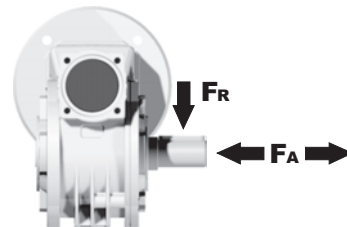

n ₂ [min ⁻¹]	FA [N]	FR [N]
200	180	900
150	200	1000
100	220	1100
75	240	1200
50	260	1400
25	300	1800
15	400	2000

Input shaft
albero in entrata

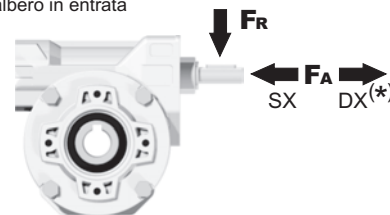

n ₁ [min ⁻¹]	FA [N]	FR [N]
1400	42	210

*Strong axial loads in the DX direction are not allowed.
 Non sono consentiti forti carichi assiali con direzione DX

tab. 2

▪ **SELECT THIS TYPE AND THIS SPECIFIC SIZE ON THE WEB PAGES TO GET COMPLETE TECHNICAL DATA.**
 Selezionare tipo e gandezza specifica nel sito web per la documentazione completa.

P045FB... Basic wormbox
Riduttore base

Wormbox weight
peso riduttore **2.40 kg**

M. flanges	Kit code	øF	A
63B5	K050.4.041	138	72
71B5	K050.4.042	160	70
56B14	KC40.4.049	80	71.5
63B14	K050.4.047	90	74
71B14	K050.4.045	105	71.5

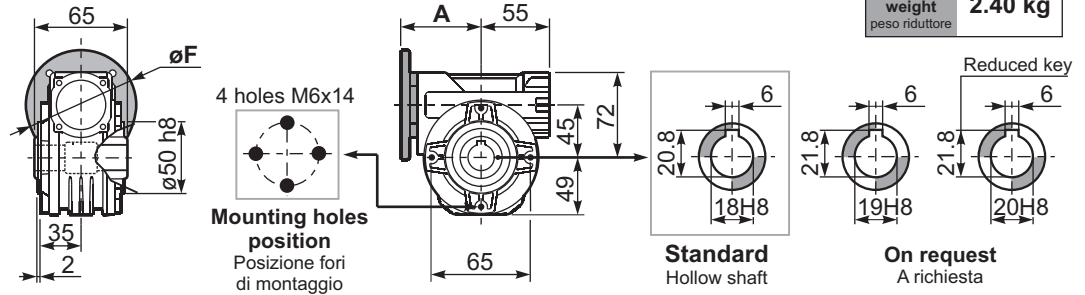

P045PA... Feet
Piedini

P045PB... Feet
Piedini

P045PV... Feet
Piedini

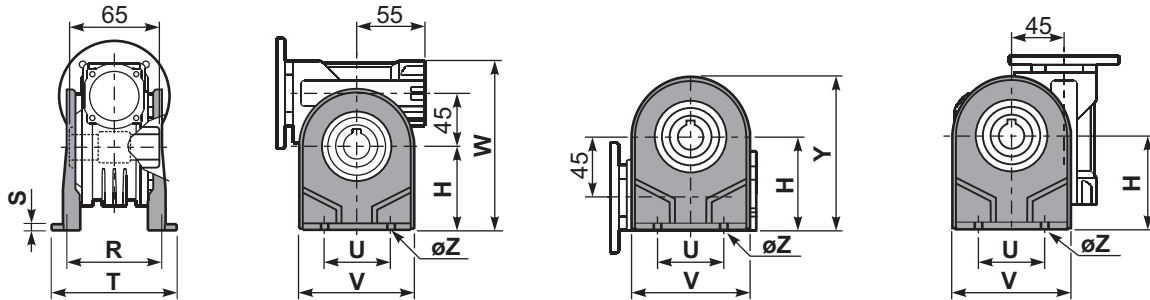

	H	R	S	T	U	V	Y	W	øZ	kit code
type B	72	81	3	100	52	98	121	144	ø10.5	K045.9.022
type S	71	84	8	100	70	90	120	143	ø8	KS045.9.023

P045FC... Output flange
Flangia uscita

P045BR... Reaction arm
Braccio di reazione

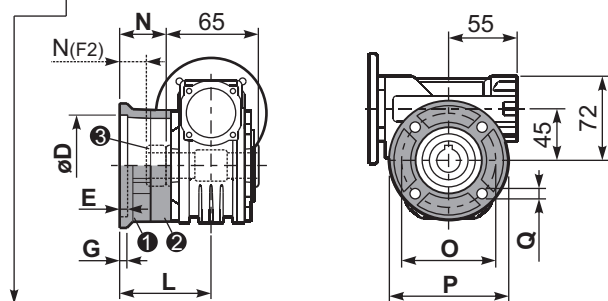

type B	øD	E	G	L	N	O	P	Q	kit code
FC	60 ^{+0.15} / _{+0.05}	9	9	60.5	28	87	110	8.5	① K045.9.010 ② -
FL	60 ^{+0.15} / _{+0.05}	9	9	90.5	58	87	110	8.5	① K045.9.010 ② K045.0.200

type S	øD	E	G	L	N	O	P	Q	kit code
F1	95 ^{+0.20} / _{+0.15}	4	11	73.5	41	115	140	9	① KS045.9.013 ② -
F2	60 ^{+0.15} / _{+0.05}	9	9	60.5	19	87	110	8.5	① KS045.9.010 ② S045.0.204
F3	80 ^{+0.15} / _{+0.10}	3	8	51.5	19	100	120	9	① KS045.9.014 ② -

P045.....S... Single Shaft
Albero lento semplice

P045.....D... Double Shaft
Albero lento bisp.

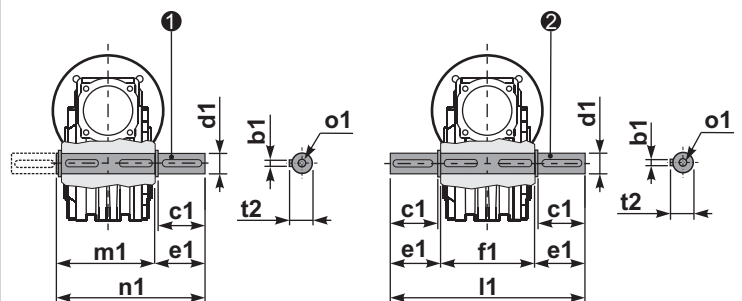

① kit cod. K045.5.028 type B
kit cod. KS045.5.030 type S

② kit cod. K045.5.029 type B
kit cod. KS045.5.031 type S

R045FB... Input shaft
Albero in entrata

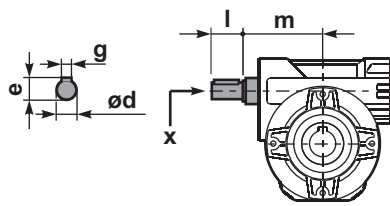

	ød	e	g	l	m	x	kit code
type B	11 h6	12.5	4	30	68	-	① ② K045.5.006 PAM71
type S	-	-	-	-	-	-	① ② -

	b1	c1	d1	e1	f1	l1	m1	n1	t2	o1
type B	6	32	18 ^{-0.005} / _{-0.020}	43	65	151	70	113	20.5	M6x18
type S	6	40	19 ^{-0.005} / _{-0.020}	58.8	65	182	70	128.5	21.5	M8x20



QUICK SELECTION / Selezione veloce										input speed (n ₁) = 1400 min ⁻¹						
Output Speed n ₂ [min ⁻¹]	Ratio i	Motor power P _{1M} [kW]	Output torque M _{2M} [Nm]	Service factor f.s.	Nominal power P _{1R} [kW]	Nominal torque M _{2R} [Nm]	Available B5 motor flanges			Available B14 motor flanges				Dynamic efficiency RD	Tooth Module Mn [mm]	Ratios code
							B	C	D	O	P	Q	R			
							63	71	80	56	63	71	80			
200	7	0.75	29	1.8	1.4	54	B	B			B-C	B		82	2.5	01
140	10	0.75	41	1.4	1.1	59	B	B			B-C	B		80	2.4	02
100	14	0.75	57	1.1	0.86	65	B	B			B-C	B		79	2.6	03
78	18	0.55	51	1.2	0.64	59	B	B			B-C	B		75	2.0	04
54	26	0.55	67	0.9	0.51	63	B	B			B-C	B		69	2.7	05
39	36	0.37	63	1.1	0.41	69	B			B-C	B-C			69	2.1	06
33	43	0.37	72	0.9	0.34	65	B			B-C	B-C			66	1.8	07
23	60	0.25	59	1.0	0.25	59	B			B-C	B-C			58	1.3	08
21	68	0.25	66	0.8	0.21	55	B			B-C	B-C			57	1.2	09
17.5	80	0.18	53	1.0	0.18	54	B			B-C	B-C			54	1.0	10
14	100	0.12	41	1.2	0.14	49	B			B-C	B-C			50	0.8	11

Motor Flanges Available
Flange Motore Disponibili

B) Supplied with Reduction Bushing
Fornito con Bussola di Riduzione

B) Available on Request without reduction bushing
Disponibile a Richiesta senza Bussola di Riduzione

C) Motor Flange Holes Position
Posizione Fori Flangia Motore

EN Unit 050 is supplied with synthetic oil, providing "long life" lubrication. For mounting position V5-V6 please contact us. See table 1 for lubrication and recommended quantity. In table 2 please see possible radial loads and axial loads on the gearbox. For complete documentation please visit our web site.

I Il riduttore tipo 050 viene fornito lubrificato a vita con olio sintetico. Per posizioni V5-V6 contattare il ns. servizio tecnico. Vedi tab.1 per oli e quantità consigliati. In tab.2 sono presenti i carichi radiali e assiali applicabili al riduttore. Per la documentazione completa consulta il nostro sito.

D Für die Lebensdauerschmierung ist das Getriebe der Größe 050 mit synthetischem Öl befüllt. Bei Einbaulage V5 oder V6 bitten wir um Rücksprache. In Tabelle 1 ist die Schmiermenge und das empfohlene Schmiermittel angegeben. In Tabelle 2 sind die zulässigen Radial- und Axialbelastungen des Getriebes aufgeführt. Die komplette Dokumentation, Wartungs- und Inbetriebnahmeanleitungen finden Sie unter.

E El reductor tamaño 050 se suministra, lubricado de por vida con aceite sintético. Para las posiciones V5 y V6 contactar con nuestro servicio técnico. Ver tabla 1, para cantidades y aceites recomendados. En la tabla 2, se encuentran las cargas radiales y axiales admitidas por el reductor. Para documentación completa, consultar nuestra Web.

• LUBRICATION 050 Oil Quantity 0.14 Lt.

AGIP	KLUBER	SHELL	MOBIL
Telium VSF 320	Syntheso D220 EP	Tivela Oil WB	Glygoyl 30 SHC 630

tab. 1

• RADIAL AND AXIAL LOADS

Output shaft Albero di uscita

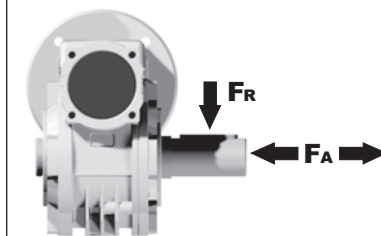

n ₂ [min ⁻¹]	FA [N]	FR [N]
200	240	1200
150	280	1400
100	300	1500
75	340	1700
50	380	1900
25	480	2500
15	560	2800

Input shaft albero in entrata

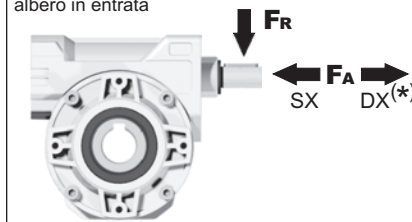

n ₁ [min ⁻¹]	FA [N]	FR [N]
1400	76	380

*Strong axial loads in the DX direction are not allowed.
Non sono consentiti forti carichi assiali con direzione DX

tab. 2

SELECT THIS TYPE AND THIS SPECIFIC SIZE ON THE WEB PAGES TO GET COMPLETE TECHNICAL DATA.
Selezionare tipo e gandezza specifica nel sito web per la documentazione completa.

P050FB... Basic wormbox
Riduttore base

Wormbox weight
peso riduttore **3.00 kg**

M. flanges	Kit code	øF	A
63B5	K050.4.041	138	76.5
71B5	K050.4.042	160	74.5
80B5	K050.4.043	200	76.5
56B14	KC40.4.049	80	76
63B14	K050.4.047	90	78.5
71B14	K050.4.045	105	76
80B14	K050.4.046	120	76.5

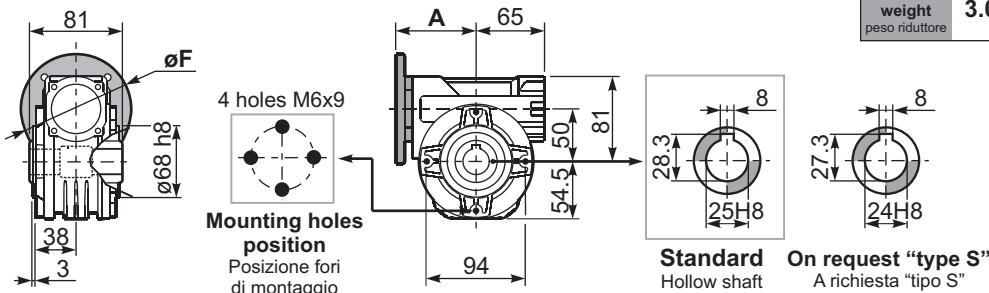

P050PA... Feet
Piedini

P050PB... Feet
Piedini

P050PV... Feet
Piedini

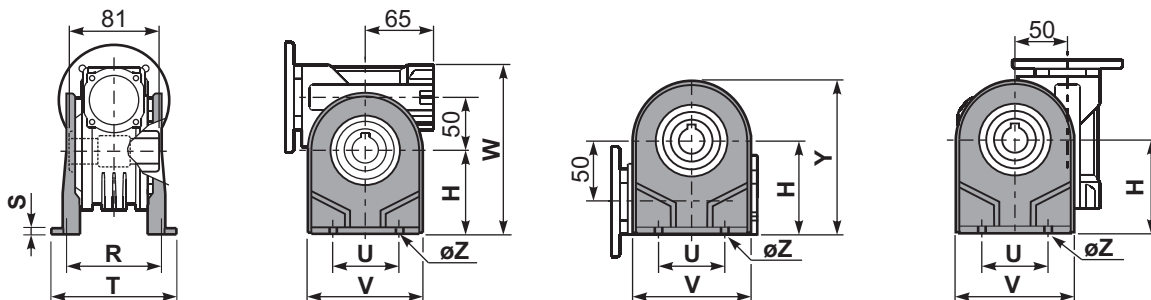

	H	R	S	T	U	V	Y	W	øZ	kit code
type B	82	98.5	3.5	123	63	113	138.5	163	ø10.5	K050.9.022
type S	85	96	10	114	85	110	139.5	166	ø10	KS050.9.023

P050FC... Output flange
Flangia uscita

P050BR... Reaction arm
Braccio di reazione

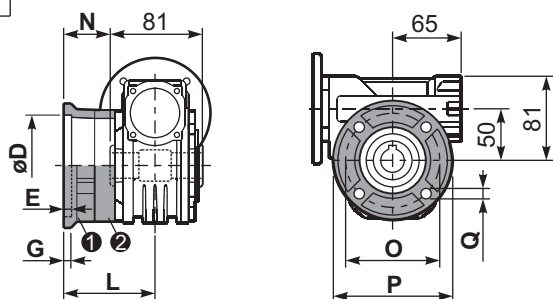

type B	øD	E	G	L	N	O	P	Q	kit code
FC	70 ^{+0.20} / _{+0.15}	9	12	85	44.5	90	123	10.5	① K050.9.010 ② -
FL	70 ^{+0.20} / _{+0.15}	9	12	114.5	74	90	123	10.5	① K050.9.010 ② K050.0.200
type S	øD	E	G	L	N	O	P	Q	kit code
F1	110 ^{+0.20} / _{+0.15}	4	11	83.5	43	130	160	10	① KS050.9.012 ② -
F2	70 ^{+0.20} / _{+0.15}	9	12	76.5	36	90	123	10.5	① KS050.9.014 ② -
F3	95 ^{+0.20} / _{+0.15}	4	10	66.5	26	115	140	10	① KS050.9.013 ② -

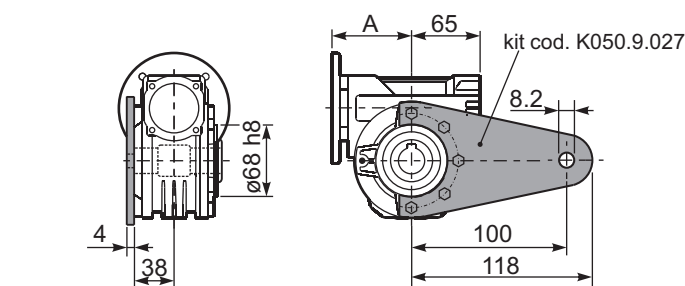

P050.....S... Single Shaft
Albero lento semplice

P050.....D... Double Shaft
Albero lento bisp.

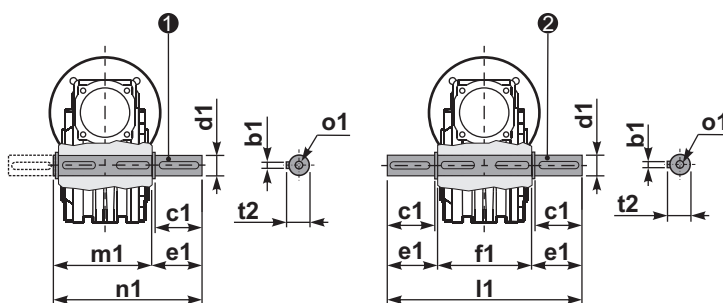

① kit cod. K050.5.028 type B
kit cod. KS050.5.030 type S

② kit cod. K050.5.029 type B
kit cod. KS050.5.031 type S

R050FB... Input shaft
Albero in entrata

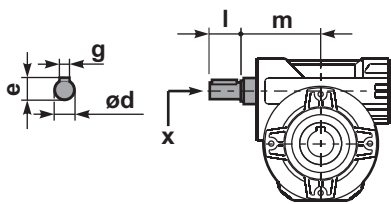

	ød	e	g	l	m	x	kit code
type B	16 h6	18	5	30	74.5	M6x16	① K050.5.006 PAM71 ② K050.5.007 PAM80
type S	14 h6	16	5	30	74.5	M5x10	① KS050.5.008 PAM71 ② KS050.5.009 PAM80

	b1	c1	d1	e1	f1	l1	m1	n1	t2	o1
type B	8	52	25 ^{-0.005} / _{-0.020}	59.5	81	200	86.5	146	28	M8x20
type S	8	50	24 ^{-0.005} / _{-0.020}	68.8	81	218	86.5	155	27	M8x20



QUICK SELECTION / Selezione veloce										input speed (n ₁) = 1400 min ⁻¹							
Output Speed n ₂ [min ⁻¹]	Ratio i	Motor power P _{1M} [kW]	Output torque M _{2M} [Nm]	Service factor f.s.	Nominal power P _{1R} [kW]	Nominal torque M _{2R} [Nm]	Available B5 motor flanges				Available B14 motor flanges			Dynamic efficiency RD	Tooth Module Mn [mm]	Ratios code	
							B	C	D	E	Q	R	T				
200	7	1.8	71	1.7	3.0	119		B	B			B-C	B-C		83	3.1	01
140	10	1.8	99	1.3	2.3	128		B	B			B-C	B-C		81	3.1	02
93	15	1.5	121	1.1	1.6	131		B	B			B-C	B-C		79	3.1	03
74	19	1.1	111	1.2	1.3	131		B	B			B-C	B-C		78	2.6	04
58	24	1.1	135	1.0	1.1	135		B	B			B-C	B-C		75	2.0	05
47	30	1.1	167	0.8	0.92	139		B	B			B-C	B-C		74	3.2	06
39	36	0.75	125	1.1	0.84	140		B	B	B		B-C	B-C		68	2.7	07
31	45	0.55	111	1.2	0.64	129	B	B				B-C	C		66	2.1	08
21	67	0.55	151	0.8	0.43	118	B	B				B-C	C		60	1.5	09
17.5	80	0.37	115	1.0	0.36	113	B	B				B-C	C		57	1.3	10
14.9	94	0.37	123	0.9	0.34	113	B	B				B-C	C		52	1.1	11

Motor Flanges Available
Flange Motore Disponibili

B) Supplied with Reduction Bushing
Fornito con Bussola di Riduzione

B) Available on Request without reduction bushing
Disponibile a Richiesta senza Bussola di Riduzione

C) Motor Flange Holes Position
Posizione Fori Flangia Motore

EN Unit 063 is supplied with synthetic oil, providing "long life" lubrication. For mounting position V5-V6 please contact us. See table 1 for lubrication and recommended quantity. In table 2 please see possible radial loads and axial loads on the gearbox. For complete documentation please visit our web site.

I Il riduttore tipo 063 viene fornito lubrificato a vita con olio sintetico. Per posizioni V5-V6 contattare il ns. servizio tecnico. Vedi tab.1 per oli e quantità consigliati. In tab.2 sono presenti i carichi radiali e assiali applicabili al riduttore. Per la documentazione completa consulta il nostro sito.

D Für die Lebensdauerschmierung ist das Getriebe der Größe 063 mit synthetischem Öl befüllt. Bei Einbaulage V5 oder V6 bitten wir um Rücksprache. In Tabelle 1 ist die Schmiermenge und das empfohlene Schmiermittel angegeben. In Tabelle 2 sind die zulässigen Radial- und Axialbelastungen des Getriebes aufgeführt. Die komplette Dokumentation, Wartungs- und Inbetriebnahmeanleitungen finden Sie unter.

E El reductor tamaño 063 se suministra, lubricado de por vida con aceite sintético. Para las posiciones V5 y V6 contactar con nuestro servicio técnico. Ver tabla 1, para cantidades y aceites recomendados. En la tabla 2, se encuentran las cargas radiales y axiales admitidas por el reductor. Para documentación completa, consultar nuestra Web.

LUBRICATION 063 Oil Quantity 0.40 Lt.

AGIP	KLUBER	SHELL	MOBIL
Telium VSF 320	Syntheso D220 EP	Tivela Oil WB	Glygoyl 30 SHC 630

tab. 1

RADIAL AND AXIAL LOADS

Output shaft

Albero di uscita

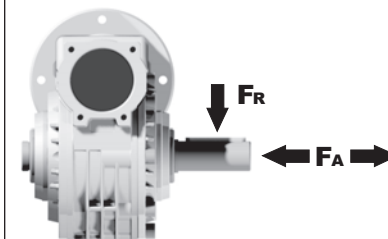

n ₂ [min ⁻¹]	FA [N]	FR [N]
200	360	1800
150	400	2000
100	460	2300
75	500	2500
50	600	3000
25	700	3800
15	800	4000

Input shaft

albero in entrata

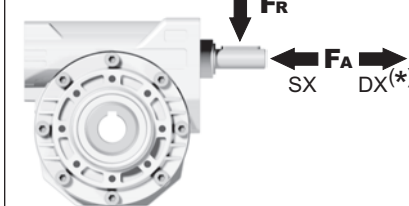

n ₁ [min ⁻¹]	FA [N]	FR [N]
1400	90	450

*Strong axial loads in the DX direction are not allowed.
Non sono consentiti forti carichi assiali con direzione DX

tab. 2

SELECT THIS TYPE AND THIS SPECIFIC SIZE ON THE WEB PAGES TO GET COMPLETE TECHNICAL DATA.
Selezionare tipo e gandezza specifica nel sito web per la documentazione completa.

P063FB... Basic wormbox
Riduttore base

Wormbox weight
peso riduttore **6.00 kg**

M. flanges	Kit code	øF	A
63B5	K063.4.041	140	99.5
71B5	K063.4.042	160	97.5
80/90B5	K063.4.043	200	99.5
71B14	K063.4.047	105	97.5
80B14	K063.4.046	120	98.5
90B14	K063.4.041	140	99.5

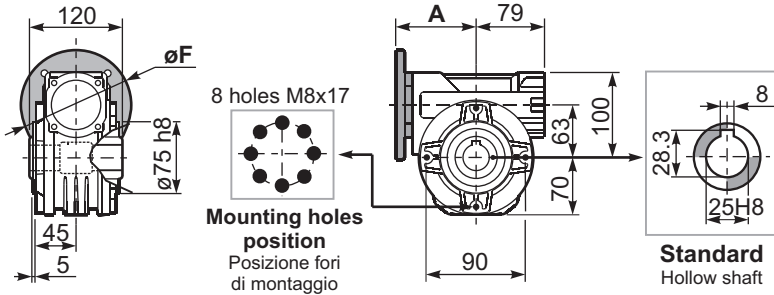

P063PA... Feet
Piedini

P063PB... Feet
Piedini

P063PV... Feet
Piedini

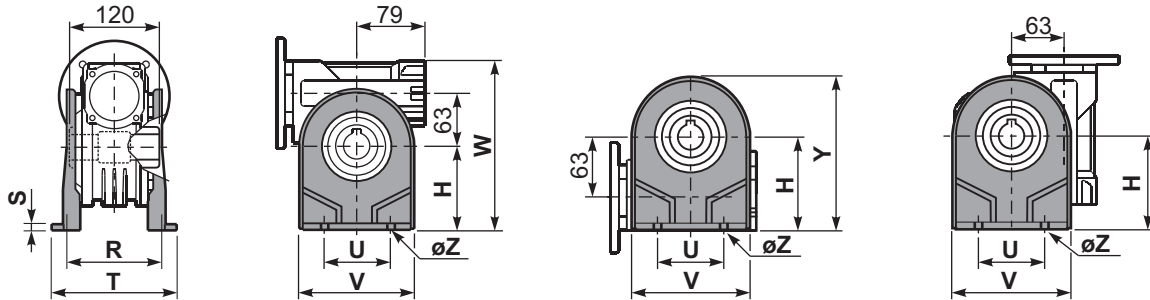

	H	R	S	T	U	V	Y	W	øZ	kit code
type B	100	111	4	144	95	133	170	200	ø10.5	K063.9.022
type S	-	-	-	-	-	-	-	-	-	-

P063FC... Output flange
Flangia uscita

P063BR... Reaction arm
Braccio di reazione

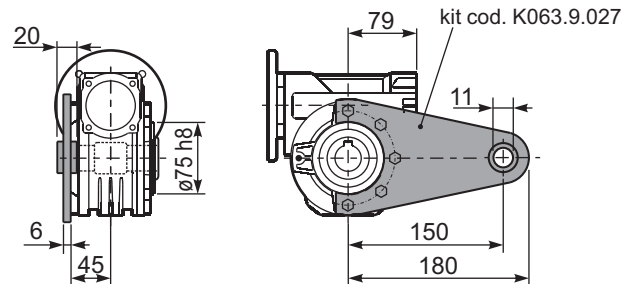
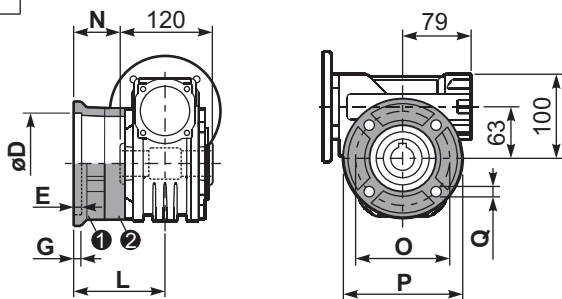

type B	øD	E	G	L	N	O	P	Q	kit code
FC	115 ^{+0.20} / _{+0.15}	7	13	86	26	150	175	11	1 K063.9.010 2 -
FL	115 ^{+0.20} / _{+0.15}	7	13	116	56	150	175	11	1 K063.9.010 2 K063.0.200

type S	øD	E	G	L	N	O	P	Q	kit code
F1	130 ^{+0.20} / _{+0.15}	7	13	102	42	165	200	13	1 KS070.9.013 2 -
F2	115 ^{+0.20} / _{+0.15}	7	13	116	56	150	175	11	1 KS063.9.013 2 -
F3	110 ^{+0.035} / ₀	5	11	82	22	130	160	10	1 KS063.9.011 2 -

P063.....S... Single Shaft
Albero lento semplice

P063.....D... Double Shaft
Albero lento bisp.

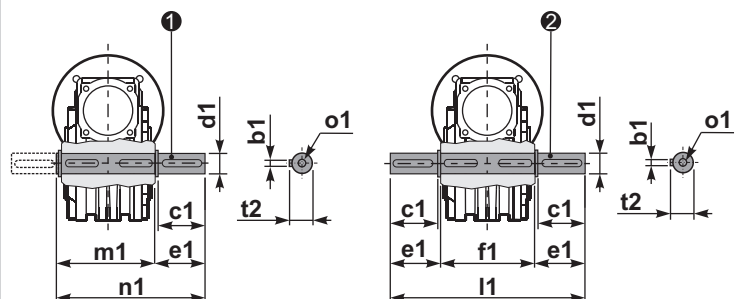

1 kit cod. K063.5.028 type B

2 kit cod. K063.5.029 type B

R063FB... Input shaft
Albero in entrata

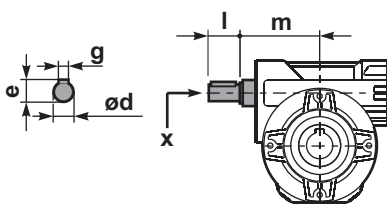

	ød	e	g	l	m	x	kit code
type B	18 h6	20.5	6	45	93	M6x16	1 K063.5.006 PAM80 2 K063.5.007 PAM90
type S	19 h6	21.5	6	40	93	M8x20	1 KS063.5.008 PAM80 2 KS063.5.009 PAM90

	b1	c1	d1	e1	f1	l1	m1	n1	t2	o1
type B	8	60	25 ^{-0.005} / _{-0.020}	63.2	120	246.4	126.8	190	28	M8x20
type S	-	-	-	-	-	-	-	-	-	-



QUICK SELECTION / Selezione veloce							input speed (n_1) = 1400 min ⁻¹										
Output Speed n_2 [min ⁻¹]	Ratio i	Motor power P_{1M} [kW]	Output torque M_{2M} [Nm]	Service factor f.s.	Nominal power P_{1R} [kW]	Nominal torque M_{2R} [Nm]	Available B5 motor flanges				Available B14 motor flanges			Dynamic efficiency RD	Tooth Module Mn [mm]	Ratios code 	
							B	C	D	E	Q	R	T				
200	7	1.8	71	2.2	3.9	155		B	B			B-C	B-C		83	3.1	01
140	10	1.8	99	1.7	3.0	165		B	B			B-C	B-C		81	3.1	02
93	15	1.5	121	1.4	2.1	169		B	B			B-C	B-C		79	3.1	03
74	19	1.5	152	1.1	1.7	169		B	B			B-C	B-C		78	2.6	04
58	24	1.5	184	1.0	1.4	176		B	B			B-C	B-C		75	2	05
47	30	1.5	227	0.8	1.2	180		B	B			B-C	B-C		74	3.2	06
39	36	1.1	184	1.0	1.1	181		B	B	B		B-C	B-C		68	2.7	07
31	45	0.75	152	1.1	0.82	167	B	B				B-C	C		66	2.1	08
21	67	0.55	151	1.0	0.55	151	B	B				B-C	C		60	1.5	09
17.5	80	0.37	115	1.3	0.47	146	B	B				B-C	C		57	1.3	10
14.9	94	0.37	123	1.0	0.37	124	B	B				B-C	C		52	1.1	11

Motor Flanges Available
Flange Motore Disponibili

B) Supplied with Reduction Bushing
Fornito con Bussola di Riduzione

B) Available on Request without reduction bushing
Disponibile a Richiesta senza Bussola di Riduzione

C) Motor Flange Holes Position
Posizione Fori Flangia Motore

EN Unit 63A is supplied with synthetic oil, providing "long life" lubrication. For mounting position V5-V6 please contact us. See table 1 for lubrication and recommended quantity. In table 2 please see possible radial loads and axial loads on the gearbox. For complete documentation please visit our web site.

I Il riduttore tipo 63A viene fornito lubrificato a vita con olio sintetico. Per posizioni V5-V6 contattare il ns. servizio tecnico. Vedi tab.1 per oli e quantità consigliati. In tab.2 sono presenti i carichi radiali e assiali applicabili al riduttore. Per la documentazione completa consulta il nostro sito.

D Für die Lebensdauerschmierung ist das Getriebe der Größe 63A mit synthetischem Öl befüllt. Bei Einbaulage V5 oder V6 bitten wir um Rücksprache. In Tabelle 1 ist die Schmiermenge und das empfohlene Schmiermittel angegeben. In Tabelle 2 sind die zulässigen Radial - und Axialbelastungen des Getriebes aufgeführt. Die komplette Dokumentation, Wartungs - und Inbetriebnahmeanleitungen finden Sie unter.

E El reductor tamaño 63A se suministra, lubricado de por vida con aceite sintético. Para las posiciones V5 y V6 contactar con nuestro servicio técnico. Ver tabla 1, para cantidades y aceites recomendados. En la tabla 2, se encuentran las cargas radiales y axiales admitidas por el reductor. Para documentación completa, consultar nuestra Web.

• LUBRICATION 63A Oil Quantity 0.40 Lt.

AGIP	KLUBER	SHELL	MOBIL
Telium VSF 320	Syntheso D220 EP	Tivela Oil WB	Glygoyl 30 SHC 630

tab. 1

• RADIAL AND AXIAL LOADS

Output shaft

Albero di uscita

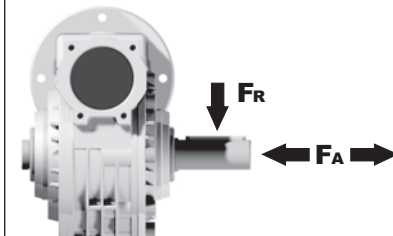

n_2 [min ⁻¹]	FA [N]	FR [N]
200	360	1800
150	400	2000
100	460	2300
75	500	2500
50	600	3000
25	700	3800
15	800	4000

Input shaft

albero in entrata

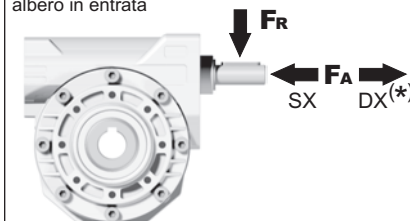

n_1 [min ⁻¹]	FA [N]	FR [N]
1400	90	450

*Strong axial loads in the DX direction are not allowed.
Non sono consentiti forti carichi assiali con direzione DX

tab. 2

SELECT THIS TYPE AND THIS SPECIFIC SIZE ON THE WEB PAGES TO GET COMPLETE TECHNICAL DATA.
Selezionare tipo e gandezza specifica nel sito web per la documentazione completa.

P63AFB... Basic wormbox
Riduttore base

Wormbox weight
peso riduttore **6.00 kg**

M. flanges	Kit code	øF	A
63B5	K063.4.041	140	99.5
71B5	K063.4.042	160	97.5
80/90B5	K063.4.043	200	99.5
71B14	K063.4.047	105	97.5
80B14	K063.4.046	120	98.5
90B14	K063.4.041	140	99.5

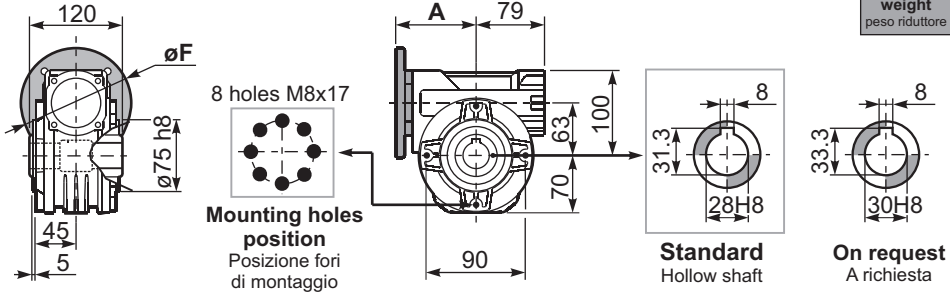

Standard
Hollow shaft

On request
A richiesta

P63APA... Feet
Piedini

P63APB... Feet
Piedini

P63APV... Feet
Piedini

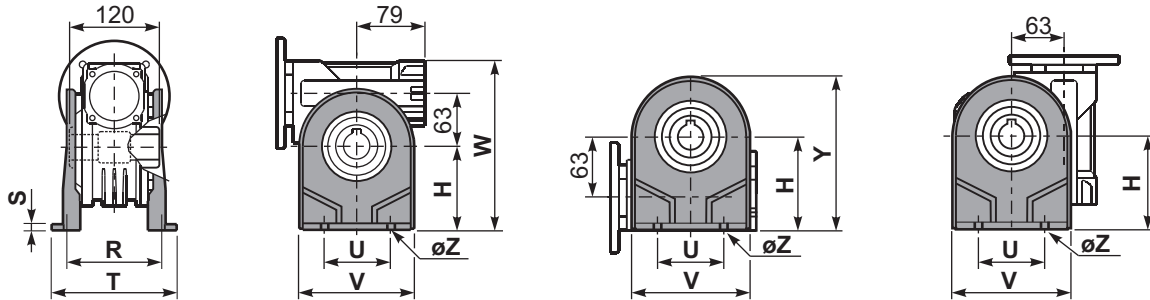

	H	R	S	T	U	V	Y	W	øZ	kit code
type B	115	115	12	142	120	156	185	215	ø11	K070.9.022
type S	-	-	-	-	-	-	-	-	-	-

P63AFC... Output flange
Flangia uscita

P63ABR... Reaction arm
Braccio di reazione

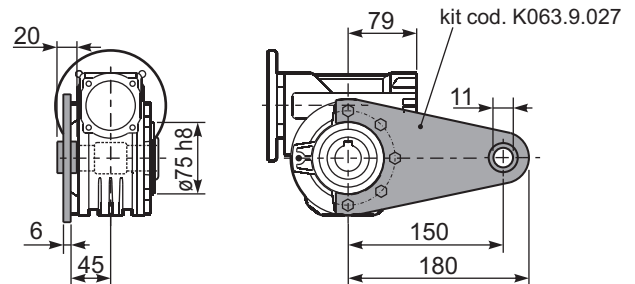
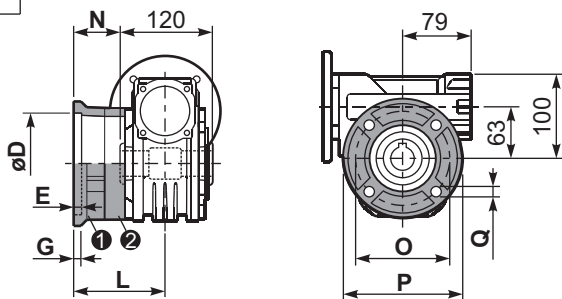

type B	øD	E	G	L	N	O	P	Q	kit code
FC	130 ^{+0.20} / _{+0.15}	7	13	85	25	165	200	13	① K070.9.010 ② -
FL	130 ^{+0.20} / _{+0.15}	7	13	111	51	165	200	13	① K070.9.010 ② K070.0.200
type S	øD	E	G	L	N	O	P	Q	kit code
F1	130 ^{+0.20} / _{+0.15}	7	13	111	51	165	200	13	① KS070.9.014 ② -
F2	115 ^{+0.20} / _{+0.15}	7	13	116	56	150	175	11	① KS063.9.013 ② -
F3	110 ^{+0.035} / ₀	5	13.5	84.5	24.5	130	160	11	① KS070.9.011 ② -

P63A.....S... Single Shaft
Albero lento semplice

P63A.....D... Double Shaft
Albero lento bisp.

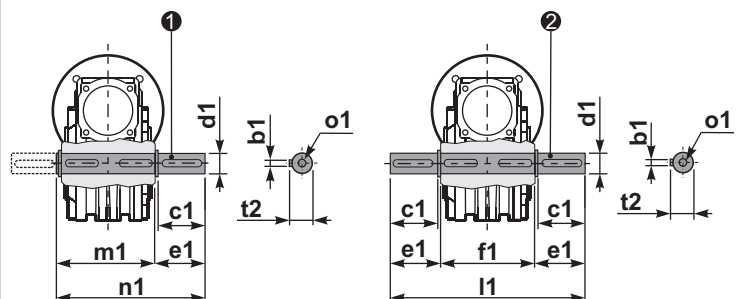

① kit cod. K070.5.028 type B

② kit cod. K070.5.029 type B

R63AFB... Input shaft
Albero in entrata

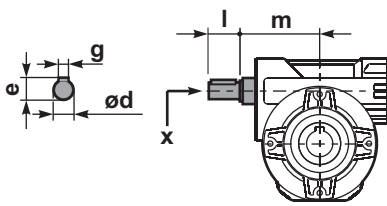

	ød	e	g	l	m	x	kit code
type B	18 h6	20.5	6	45	93	M6x16	① K063.5.006 PAM80 ② K063.5.007 PAM90
type S	19 h6	21.5	6	40	93	M8x20	① KS063.5.008 PAM80 ② KS063.5.009 PAM90

	b1	c1	d1	e1	f1	l1	m1	n1	t2	o1
type B	8	60	28 ^{-0.005} / _{-0.020}	63.5	120	247	127.5	191	31	M8x20
type S	-	-	-	-	-	-	-	-	-	-



QUICK SELECTION / Selezione veloce										input speed (n ₁) = 1400 min ⁻¹							
Output Speed n ₂ [min ⁻¹]	Ratio i	Motor power P _{1M} [kW]	Output torque M _{2M} [Nm]	Service factor f.s.	Nominal power P _{1R} [kW]	Nominal torque M _{2R} [Nm]	Available B5 motor flanges				Available B14 motor flanges			Dynamic efficiency RD	Tooth Module Mn [mm]	Ratios code	
							C	D	E	F	R	T	U				
							71	80	90	100 112	80	90	100 112				
200	7	4.0	168	1.5	5.8	245		B	B			B	B		88	4.23	01
140	10	4.0	218	1.2	4.9	270		B	B			B	B		80	4.2	02
100	14	3.0	223	1.3	3.9	290		B	B			B	B		78	4.5	03
70	20	2.2	237	1.2	2.6	280		B	B			B	B		79	3.4	04
64	22	2.2	258	1.1	2.4	280		B	B			B	B		78	3.1	05
50	28	2.2	315	1.0	2.3	330		B	B	B		B	B		75	4.7	06
37	38	1.5	276	1.2	1.7	320	B	B	B			B	B		71	3.5	07
30	46	1.5	320	1.0	1.4	310	B	B				B	B		68	3.1	08
27	52	1.1	258	1.1	1.2	275	B	B				B			66	2.7	09
21	67	1.1	327	0.8	0.93	275	B	B				B			65	2.1	10
18.9	74	0.75	220	1.2	0.87	255	B	B				B			58	1.9	11
14.6	96	0.55	191	1.2	0.66	230	B	B				B			53	1.5	12

Motor Flanges Available Flange Motore Disponibili
 B Supplied with Reduction Bushing Fornito con Bussola di Riduzione
 B Available on Request without reduction bushing Disponibile a Richiesta senza Bussola di Riduzione
 C Motor Flange Holes Position Posizione Fori Flangia Motore

EN Unit 085 is supplied with synthetic oil, providing "long life" lubrication. For mounting position V5-V6 please contact us. See table 1 for lubrication and recommended quantity. In table 2 please see possible radial loads and axial loads on the gearbox. For complete documentation please visit our web site.

I Il riduttore tipo 085 viene fornito lubrificato a vita con olio sintetico. Per posizioni V5-V6 contattare il ns. servizio tecnico. Vedi tab.1 per oli e quantità consigliati. In tab.2 sono presenti i carichi radiali e assiali applicabili al riduttore. Per la documentazione completa consulta il nostro sito.

D Für die Lebensdauerschmierung ist das Getriebe der Größe 085 mit synthetischem Öl befüllt. Bei Einbaulage V5 oder V6 bitten wir um Rücksprache. In Tabelle 1 ist die Schmiermenge und das empfohlene Schmiermittel angegeben. In Tabelle 2 sind die zulässigen Radial- und Axialbelastungen des Getriebes aufgeführt. Die komplette Dokumentation, Wartungs- und Inbetriebnahmeanleitungen finden Sie unter.

E El reductor tamaño 085 se suministra, lubricado de por vida con aceite sintético. Para las posiciones V5 y V6 contactar con nuestro servicio técnico. Ver tabla 1, para cantidades y aceites recomendados. En la tabla 2, se encuentran las cargas radiales y axiales admitidas por el reductor. Para documentación completa, consultar nuestra Web.

LUBRICATION 085 Oil Quantity 1.20 Lt.			
AGIP	KLUBER	SHELL	MOBIL
Telium VSF 320	Syntheso D220 EP	Tivela Oil WB	Glygoyl 30 SHC 630

tab. 1

RADIAL AND AXIAL LOADS			
Output shaft Albero di uscita			
	n ₂ [min ⁻¹]	FA [N]	FR [N]
	200	500	2500
	150	580	2900
	100	600	3000
	75	700	3500
	50	800	4000
	25	1000	5000
	15	1160	5800
Input shaft albero in entrata			
	n ₁ [min ⁻¹]	FA [N]	FR [N]
	1400	160	809
*Strong axial loads in the DX direction are not allowed. Non sono consentiti forti carichi assiali con direzione DX			

tab. 2

SELECT THIS TYPE AND THIS SPECIFIC SIZE ON THE WEB PAGES TO GET COMPLETE TECHNICAL DATA.
Selezionare tipo e gandezza specifica nel sito web per la documentazione completa.

P085FB... Basic wormbox
Riduttore base

Wormbox weight
peso riduttore **11.00 kg**

M. flanges	Kit code	øF	A
71B5	K023.4.041	160	116
80/90B5	K023.4.042	200	118
100/112B5	K023.4.043	250	124
80B14	K085.4.046	120	116
90B14	K085.4.045	140	116
100/112B14	K023.4.041	160	116

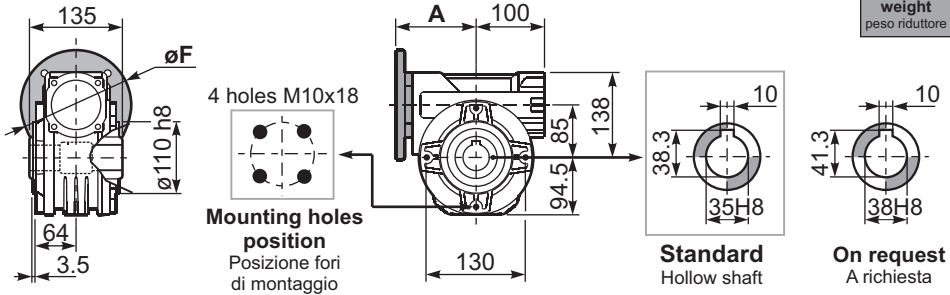

P085PA... Feet
Piedini

P085PB... Feet
Piedini

P085PV... Feet
Piedini

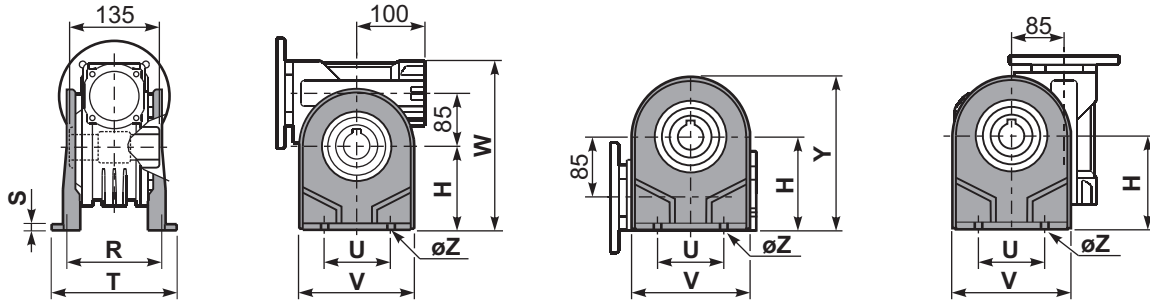

	H	R	S	T	U	V	Y	W	øZ	kit code
type B	142	145	5	182	140	180	236.5	280	ø10.5	K085.9.022
type S	-	-	-	-	-	-	-	-	-	-

P085FC... Output flange
Flangia uscita

P085BR... Reaction arm
Braccio di reazione

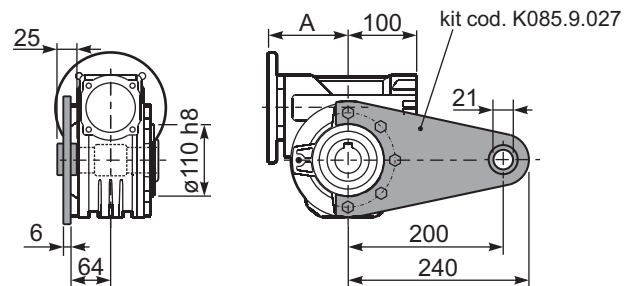
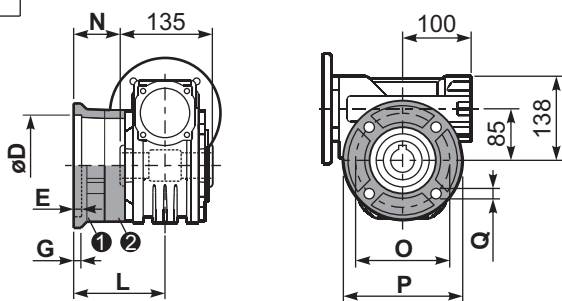

type B	øD	E	G	L	N	O	P	Q	kit code
FC	152 ^{+0.06} / _{+0.00}	5	16	108	40.5	176	205	13	① K085.9.010 ② -
FL	152 ^{+0.06} / _{+0.00}	5	16	148.5	81	176	205	13	① K085.9.010 ② K085.0.201
type S	øD	E	G	L	N	O	P	Q	kit code
F1	130 H7	5	13	117.5	50	165	200	11.5	① KS085.9.012 ② -
F2	152 ^{+0.06} / _{+0.00}	5	15	147.5	80	180	205	12.5	① KS085.9.013 ② -
F4	130 H7	5	13	106.5	39	165	200	13	① KS085.9.015 ② -

P085.....S... Single Shaft
Albero lento semplice

P085.....D... Double Shaft
Albero lento bisp.

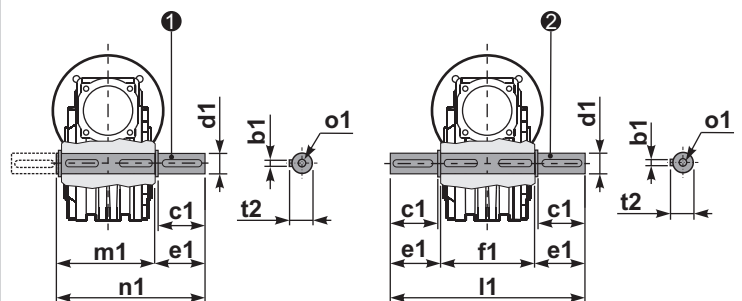

① kit cod. K085.5.028 type B

② kit cod. K085.5.029 type B

R085FB... Input shaft
Albero in entrata

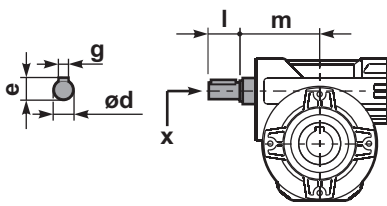

	ød	e	g	l	m	x	kit code
type B	25 h6	28	8	50	112	M8x20	① K085.5.007 PAM90 ② K085.5.008 PAM100
type S	24 h6	27	8	50	112	M8x20	① KS085.5.009 PAM90 ② KS085.5.011 PAM100

	b1	c1	d1	e1	f1	l1	m1	n1	t2	o1
type B	10	60	35 ^{-0.005} / _{-0.020}	73.5	135	282	141	214.5	38	M10x23
type S	-	-	-	-	-	-	-	-	-	-



■ QUICK SELECTION / Selezione veloce							input speed (n ₁) = 1400 min ⁻¹										
Output Speed n ₂ [min ⁻¹]	Ratio i	Motor power P _{1M} [kW]	Output torque M _{2M} [Nm]	Service factor f.s.	Nominal power P _{1R} [kW]	Nominal torque M _{2R} [Nm]	Available B5 motor flanges				Available B14 motor flanges			Dynamic efficiency RD	Tooth Module Mn [mm]	Ratios code	
							C	D	E	F	R	T	U				
200	7	4.0	168	2.7	10.9	460		B	B			B	B		88	5.5	01
140	10	4.0	235	2.1	8.5	500		B	B			B	B		86	5.4	02
88	16	4.0	358	1.4	5.7	510		B	B			B	B		82	5.3	03
70	20	4.0	447	1.2	4.6	520		B	B			B	B		82	4.5	04
61	23	3.0	377	1.3	3.9	490		B	B			B	B		80	3.9	05
47	30	3.0	467	1.3	4.0	620		B	B			B	B		76	5.6	06
37	38	3.0	583	1.0	3.1	610		B	B			B	B		75	4.7	07
31	45	2.2	493	1.2	2.5	570		B	B			B	B		73	4.0	08
26	53	2.2	557	1.1	2.3	590		B	B			B	B		70	3.5	09
22	64	1.5	452	1.1	1.7	510	B	B				B			69	2.9	10
16.7	84	1.1	410	1.1	1.3	470	B	B				B			65	2.2	11
14.1	99	1.1	446	1.0	1.1	460	B	B				B			60	1.9	12

Motor Flanges Available Flange Motore Disponibili
 B) Supplied with Reduction Bushing Fornito con Bussola di Riduzione
 B) Available on Request without reduction bushing Disponibile a Richiesta senza Bussola di Riduzione
 C) Motor Flange Holes Position Posizione Fori Flangia Motore

EN Unit 110 is supplied without lubricant and equipped with a breather, level and drain plugs. User can add mineral oil keeping existing plugs. Should the user wish to fill it with synthetic oil, it is recommended to replace the existing plugs with a closed plug. See table 1 for lubrication and recommended quantity. In table 2 please see possible radial loads and axial loads on the gearbox. [For complete documentation please visit our web site.](#)

I Il riduttore tipo 110 è fornito privo di lubrificazione con tappi di sfiato, livello e scarico olio. L'utente può immettere olio minerale mantenendo i tappi esistenti. Se immetterà olio sintetico, dovrà sostituire i tappi esistenti con altri tipo chiuso. Tab.1 per oli e quantità consigliati. Tab.2 carichi radiali e assiali applicabili al riduttore. [Per la documentazione completa consulta il nostro sito.](#)

D Das Getriebe der Baugröße 110 wird ohne Schmiermittel geliefert. Es ist jedoch mit Einfüllschraube, Überdruckventil und Ablassschraube ausgerüstet. Das benötigte mineralische Öl kann über die Einfüllschraube eingefüllt werden. Sollte synthetisches Öl bevorzugt werden, so ist sind das eingebaute Überdruckventil durch eine geschlossenen Schraube zu ersetzen. In Tabelle 1 ist die Schmiermenge und das empfohlene Schmiermittel angegeben. In Tabelle 2 sind die zulässigen Radial - und Axialbelastungen des Getriebes aufgeführt. [Die komplette Dokumentation, Wartungs - und Inbetriebnahmeanleitungen finden Sie unter.](#)

E El reductor tamaño 110 se suministra sin lubricante, provisto de tapones de respiración, nivel y descarga de aceite. El usuario puede utilizar aceite mineral, manteniendo los tapones existentes. Si prefiere utilizar aceite sintético deberá sustituir los tapones existentes por tapones ciegos. La prerreducción se suministra con tapones ciegos, lubricado de por vida con aceite sintético. Ver tabla 1, para cantidades y aceites recomendados. En la tabla 2, se encuentran las cargas radiales y axiales admitidas por el reductor. [Para documentación completa, consultar nuestra Web.](#)

B3	B6	B7	B8	V5	V6
2.00 LT	1.50 LT	1.50 LT	2.00LT	2.00 LT	2.00LT
AGIP	BP	SHELL	KLUBER	MOBIL	
Telium VSF 320	Energol SGXP220	Tivela Oil WB	Syntheso D220 EF	Glygoyl 30	

tab. 1

■ RADIAL AND AXIAL LOADS				
Output shaft Albero di uscita		n₂ [min ⁻¹]	FA [N]	FR [N]
		200	600	2900
		150	700	3300
		100	750	3600
		75	800	4000
		50	920	4600
		25	1200	6000
		n₁ [min ⁻¹]	FA [N]	FR [N]
		1400	228	1140
		*Strong axial loads in the DX direction are not allowed. Non sono consentiti forti carichi assiali con direzione DX		

tab. 2

■ **SELECT THIS TYPE AND THIS SPECIFIC SIZE ON THE WEB PAGES TO GET COMPLETE TECHNICAL DATA.**
Selezionare tipo e gandezza specifica nel sito web per la documentazione completa.

P110FB... Basic wormbox
Riduttore base

Wormbox weight
peso riduttore **35.00 kg**

M. flanges	Kit code	øF	A
71B5	K023.4.041	160	135.5
80/90B5	K023.4.042	200	137.5
100/112B5	K023.4.043	250	143.5
80B14	K085.4.046	120	135.5
90B14	K085.4.045	140	135.5
100/112B14	K023.4.041	160	135.5

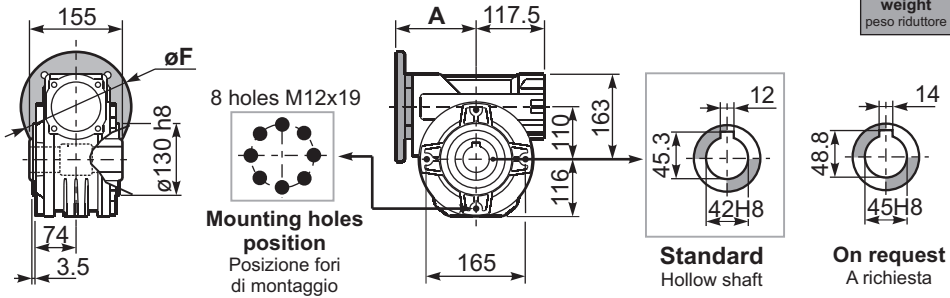

P110PA... Feet
Piedini

P110PB... Feet
Piedini

P110PV... Feet
Piedini

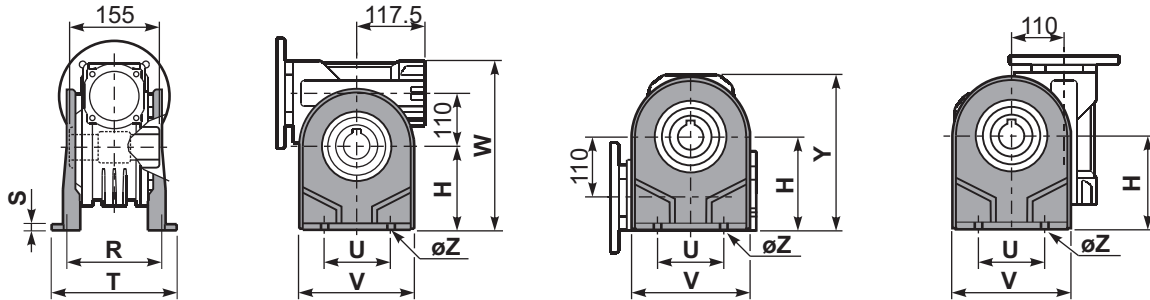

	H	R	S	T	U	V	Y	W	øZ	kit code
type B	170	180	22	224	200	240	286	333	ø13	K110.9.022
type S	172	160	18	190	200	240	288	335	ø14	KS110.9.023

P110FC... Output flange
Flangia uscita

P110BR... Reaction arm
Braccio di reazione

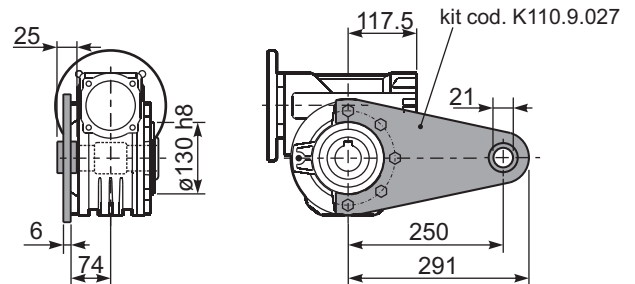
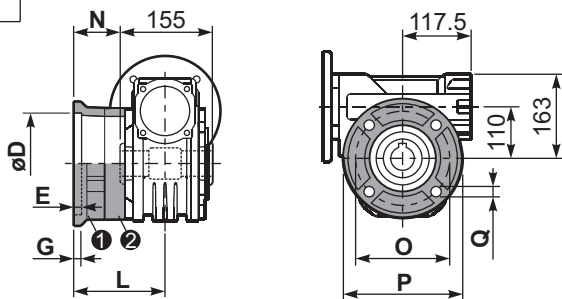

type B	øD	E	G	L	N	O	P	Q	kit code
FC	170 ^{+0.083} / _{-0.043}	11	16.5	131.5	54	230	270	13	① K110.9.010 ② -
FL	170 ^{+0.083} / _{-0.043}	11	16.5	179.5	102	230	270	13	① K110.9.011 ② -

type S	øD	E	G	L	N	O	P	Q	kit code
F1	180 ^{+0.040} / ₀	5	18	150	72.5	215	250	15	① KS110.9.014 ② -
F2	170 ^{+0.083} / _{-0.043}	9.5	15	178	100.5	230	270	13	① KS110.9.012 ② -
F3	180 ^{+0.040} / ₀	5	18	130	52.5	215	250	15	① KS110.9.013 ② -

P110.....S... Single Shaft
Albero lento semplice

P110.....D... Double Shaft
Albero lento bisp.

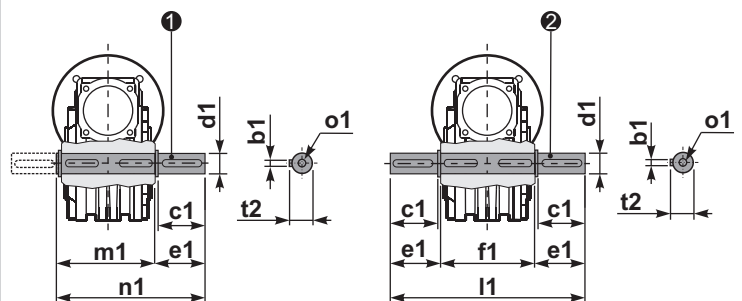

① kit cod. K110.5.028 type B

② kit cod. K110.5.029 type B

R110FB... Input shaft
Albero in entrata

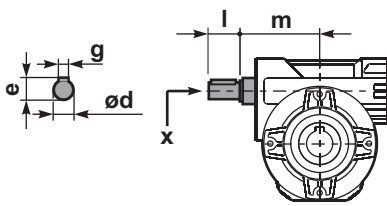

	ød	e	g	l	m	x	kit code
type B	25 h6	28	8	50	131.5	M8x20	① K085.5.007 PAM90 ② K085.5.008 PAM100
type S	24 h6	27	8	50	131.5	M8x20	① KS085.5.009 PAM90 ② KS085.5.011 PAM100

	b1	c1	d1	e1	f1	l1	m1	n1	t2	o1
type B	12	75	42 ^{-0.005} / _{-0.020}	96.5	155	348	163.5	260	45	M12x32
type S	-	-	-	-	-	-	-	-	-	-

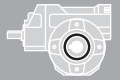

QUICK SELECTION / Selezione veloce

input speed (n_1) = 1400 min⁻¹

Output Speed n_2 [min ⁻¹]	Ratio i	Motor power P_{1M} [kW]	Output torque M_{2M} [Nm]	Service factor f.s.	Nominal power P_{1R} [kW]	Nominal torque M_{2R} [Nm]	Available B5 motor flanges		Available B14 motor flanges		Dynamic efficiency RD	Tooth Module Mn [mm]	Ratios code
							B	C	P	Q			
							63	71	63	71			
47	30.1	0.25	38	1.3	0.33	50			C		74	2.2	01
33	43.0	0.25	53	0.9	0.24	50			C		72	2.4	02
23	60.2	0.12	30	1.7	0.20	50			C		60	1.6	03
15.5	90.3	0.12	42	1.2	0.14	50			C		57	2.5	04
11.6	120	0.12	52	1.0	0.11	50			C		53	1.8	05
8.8	159	0.12	64	0.8	0.09	50			C		49	1.5	06
7.1	198	0.12*	50	<0.8	0.08	50			C		47	1.5	07
5.4	258	0.12*	50	<0.8	0.06	50			C		45	1.0	08
4.7	301	0.12*	35	<0.8	0.04	35			C		40	0.72	09
3.2	439	0.12*	35	<0.8	0.03	35			C		36	0.72	10

A Motor Flanges Available
Flange Motore Disponibili

B Supplied with Reduction Bushing
Fornito con Bussola di Riduzione

B Available on Request without reduction bushing
Disponibile a Richiesta senza Bussola di Riduzione

C Motor Flange Holes Position
Posizione Fori Flangia Motore

* Power higher than the maximum one which can be supported by the gearbox. Select according to the torque M_{2R}
Potenza superiore a quella massima sopportabile dal riduttore. Selezionare in base al momento torcente M_{2R}

EN Unit P45 is supplied with synthetic oil, providing "long life" lubrication. For mounting position V5-V6 please contact us. See table 1 for lubrication and recommended quantity. In table 2 please see possible radial loads and axial loads on the gearbox. For complete documentation please visit our web site.

I Il riduttore tipo P45 viene fornito lubrificato a vita con olio sintetico. Per posizioni V5-V6 contattare il ns. servizio tecnico. Vedi tab.1 per oli e quantità consigliati. In tab.2 sono presenti i carichi radiali e assiali applicabili al riduttore. Per la documentazione completa consulta il nostro sito

D Für die Lebensdauerschmierung ist das Getriebe der Größe P45 mit synthetischem Öl befüllt. Bei Einbaulage V5 oder V6 bitten wir um Rücksprache. In Tabelle 1 ist die Schmiermenge und das empfohlene Schmiermittel angegeben. In Tabelle 2 sind die zulässigen Radial- und Axialbelastungen des Getriebes aufgeführt. Die komplette Dokumentation, Wartungs- und Inbetriebnahmeanleitungen finden Sie unter.

E El reductor tamaño P45 se suministra, lubricado de por vida con aceite sintético. Para las posiciones V5 y V6 contactar con nuestro servicio técnico. Ver tabla 1, para cantidades y aceites recomendados. En la tabla 2, se encuentran las cargas radiales y axiales admitidas por el reductor. Para documentación completa, consultar nuestra Web.

LUBRICATION P45 Oil
Quantity 0.09/0.04 Lt.

AGIP	KLUBER	SHELL	MOBIL
Telium VSF 320	Syntheso D220 EP	Tivela Oil WB	Glygoyl 30 SHC 630

tab. 1

RADIAL AND AXIAL LOADS

Output shaft
Albero di uscita

n_2 [min ⁻¹]	FA [N]	FR [N]
75	240	1200
50	260	1400
25	300	1800
15-6	400	2000

Input shaft
albero in entrata

n_1 [min ⁻¹]	FA [N]	FR [N]
1400	44	220

***Strong axial loads in the DX direction are not allowed.**
Non sono consentiti forti carichi assiali con direzione DX

tab. 2

SELECT THIS TYPE AND THIS SPECIFIC SIZE ON THE WEB PAGES TO GET COMPLETE TECHNICAL DATA.
Selezionare tipo e gandezza specifica nel sito web per la documentazione completa.

PP45FB... Basic wormbox
Riduttore base

Wormbox weight
peso riduttore **3.20 kg**

M. flanges	Kit code	øF	A
63B5	K050.4.041	138	137.5
71B5	K050.4.042	160	135.5
63B14	K050.4.047	90	139.5
71B14	K050.4.045	105	137

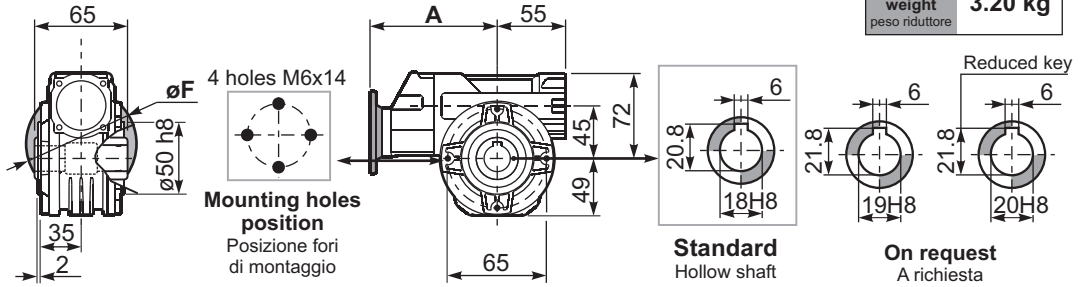

PP45PA... Feet
Piedini

PP45PB... Feet
Piedini

PP45PV... Feet
Piedini

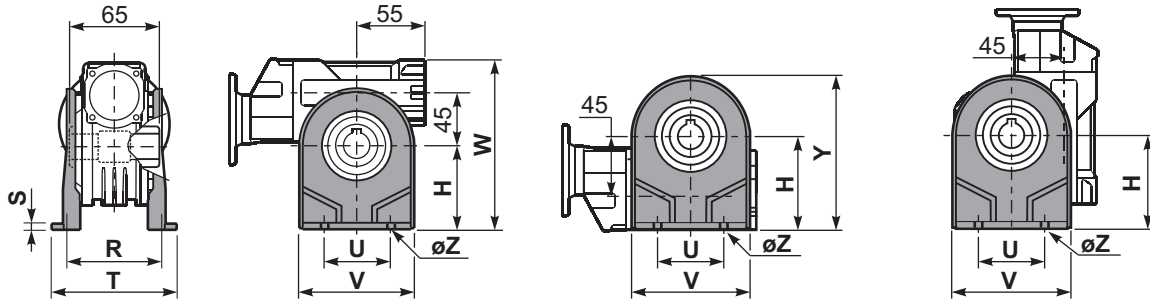

	H	R	S	T	U	V	Y	W	øZ	kit code
type B	72	81	3	100	52	98	121	144	ø10.5	K045.9.022
type S	71	84	8	100	70	90	120	143	ø8	KS045.9.023

PP45FC... Output flange
Flangia uscita

PP45BR... Reaction arm
Braccio di reazione

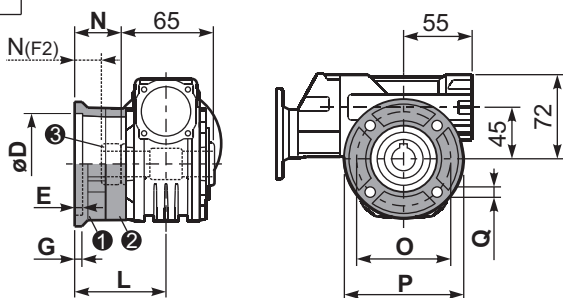

type B	øD	E	G	L	N	O	P	Q	kit code
FC	60 ^{+0.15} / _{-0.05}	9	9	60.5	28	87	110	8.5	1 K045.9.010 2 -
FL	60 ^{+0.15} / _{-0.05}	9	9	90.5	58	87	110	8.5	1 K045.9.010 2 K045.0.200

type S	øD	E	G	L	N	O	P	Q	kit code
F1	95 ^{+0.20} / _{-0.15}	4	11	73.5	41	115	140	9	1 KS045.9.013 2 -
F2	60 ^{+0.15} / _{-0.05}	9	9	60.5	19	87	110	8.5	1 KS045.9.010 2 S045.0.204
F3	80 ^{+0.03} / _{-0.00}	3	8	51.5	19	100	120	9	1 KS045.9.014 2 -

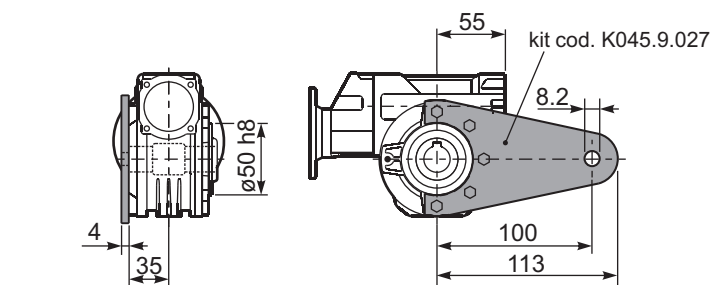

PP45.....S... Single Shaft
Albero lento semplice

PP45.....D... Double Shaft
Albero lento bisp.

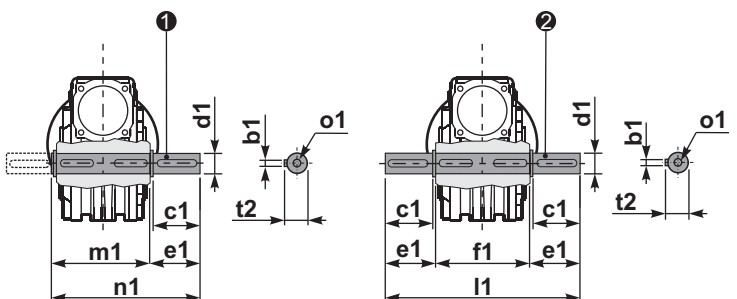

- 1 kit cod. K045.5.028 type B
kit cod. KS045.5.030 type S
- 2 kit cod. K045.5.029 type B
kit cod. KS045.5.031 type S

RP45FB... Input shaft
Albero in entrata

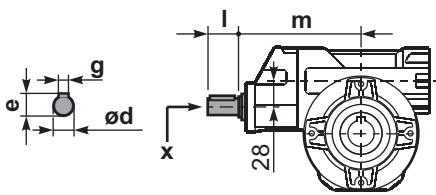

	ød	e	g	l	m	x
type B	14 j6	16	5	25	131	M5x13
type S	-	-	-	-	-	-

	b1	c1	d1	e1	f1	l1	m1	n1	t2	o1
type B	6	32	18 ^{-0.005} / _{-0.020}	43	65	151	70	113	20.5	M6x18
type S	6	40	19 ^{-0.005} / _{-0.020}	58.8	65	182	70	128.5	21.5	M8x20

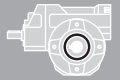

QUICK SELECTION / Selezione veloce

input speed (n_1) = 1400 min⁻¹

Output Speed n_2 [min ⁻¹]	Ratio i	Motor power P_{1M} [kW]	Output torque M_{2M} [Nm]	Service factor f.s.	Nominal power P_{1R} [kW]	Nominal torque M_{2R} [Nm]	Available B5 motor flanges		Available B14 motor flanges		Dynamic efficiency RD	Tooth Module M_n [mm]	Ratios code
							B	C	P	Q			
							63	71	63	71			
47	30.1	0.37	58	1.2	0.45	70			C		76	2.4	01
33	43.0	0.25	55	1.3	0.32	70			C		75	2.6	02
23	60.2	0.25	71	1.0	0.25	70			C		69	2.0	03
18.1	77.4	0.18	58	1.4	0.25	80			C		61	2.7	04
12.5	112	0.18	84	1.0	0.17	80			C		61	2.1	05
9.0	155	0.12	71	1.1	0.14	80			C		56	1.8	06
7.6	185	0.12	74	0.9	0.11	70			C		49	1.3	07
5.4	258	0.12*	70	<0.8	0.08	70			C		47	1.2	08
4.8	292	0.12*	60	<0.8	0.07	60			C		44	1.0	09
4.1	344	0.12*	40	<0.8	0.04	40			C		40	0.8	10
3.3	430	0.12*	40	<0.8	0.04	40			C		36	0.8	11

Motor Flanges Available Flange Motore Disponibili
 B) Supplied with Reduction Bushing Fornito con Bussola di Riduzione
 B) Available on Request without reduction bushing Disponibile a Richiesta senza Bussola di Riduzione
 C) Motor Flange Holes Position Posizione Fori Flangia Motore

* Power higher than the maximum one which can be supported by the gearbox. Select according to the torque M_{2R}
 Potenza superiore a quella massima sopportabile dal riduttore. Selezionare in base al momento torcente M_{2R}

EN Unit P50 is supplied with synthetic oil, providing "long life" lubrication. For mounting position V5-V6 please contact us. See table 1 for lubrication and recommended quantity. In table 2 please see possible radial loads and axial loads on the gearbox. For complete documentation please visit our web site.

I Il riduttore tipo P50 viene fornito lubrificato a vita con olio sintetico. Per posizioni V5-V6 contattare il ns. servizio tecnico. Vedi tab.1 per oli e quantità consigliati. In tab.2 sono presenti i carichi radiali e assiali applicabili al riduttore. Per la documentazione completa consulta il nostro sito.

D Für die Lebensdauerschmierung ist das Getriebe der Größe P50 mit synthetischem Öl befüllt. Bei Einbaulage V5 oder V6 bitten wir um Rücksprache. In Tabelle 1 ist die Schmiermenge und das empfohlene Schmiermittel angegeben. In Tabelle 2 sind die zulässigen Radial- und Axialbelastungen des Getriebes aufgeführt. Die komplette Dokumentation, Wartungs- und Inbetriebnahmeanleitungen finden Sie unter.

E El reductor tamaño P50 se suministra, lubricado de por vida con aceite sintético. Para las posiciones V5 y V6 contactar con nuestro servicio técnico. Ver tabla 1, para cantidades y aceites recomendados. En la tabla 2, se encuentran las cargas radiales y axiales admitidas por el reductor. Para documentación completa, consultar nuestra Web.

LUBRICATION P50 Oil Quantity 0.14/0.04 Lt.

AGIP	KLUBER	SHELL	MOBIL
Telium VSF 320	Syntheso D220 EP	Tivela Oil WB	Glygoyl 30 SHC 630

tab. 1

RADIAL AND AXIAL LOADS

Output shaft
Albero di uscita

n_2 [min ⁻¹]	FA [N]	FR [N]
75	340	1700
50	380	1900
25	480	2500
15-6	560	2800

Input shaft
albero in entrata

n_1 [min ⁻¹]	FA [N]	FR [N]
1400	44	220

***Strong axial loads in the DX direction are not allowed.**
 Non sono consentiti forti carichi assiali con direzione DX

tab. 2

SELECT THIS TYPE AND THIS SPECIFIC SIZE ON THE WEB PAGES TO GET COMPLETE TECHNICAL DATA.
 Selezionare tipo e gandezza specifica nel sito web per la documentazione completa.

PP50FB... Basic wormbox
Riduttore base

Wormbox weight
peso riduttore **3.80 kg**

M. flanges	Kit code	øF	A
63B5	K050.4.041	138	142
71B5	K050.4.042	160	140
63B14	K050.4.047	90	144
71B14	K050.4.045	105	141.5

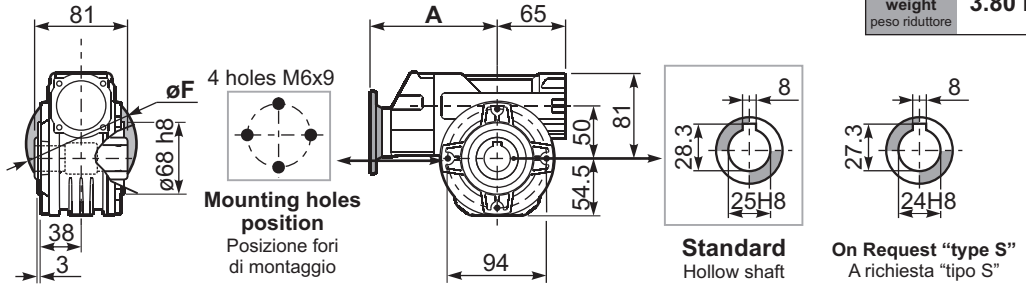

Standard
Hollow shaft

On Request "type S"
A richiesta "tipo S"

PP50PA... Feet
Piedini

PP50PB... Feet
Piedini

PP50PV... Feet
Piedini

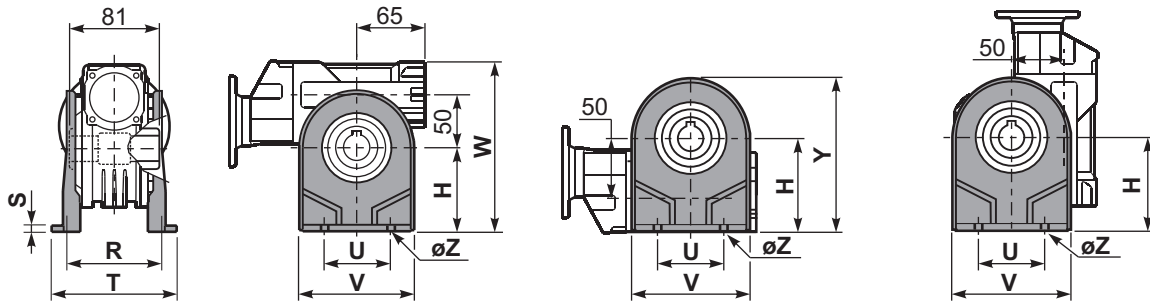

	H	R	S	T	U	V	Y	W	øZ	kit code
type B	82	98.5	3.5	123	63	113	138.5	163	ø10.5	K050.9.022
type S	85	96	10	114	85	110	139.5	166	ø10	KS050.9.023

PP50FC... Output flange
Flangia uscita

PP50BR... Reaction arm
Braccio di reazione

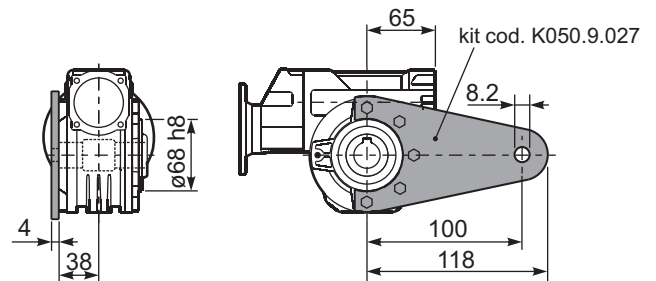
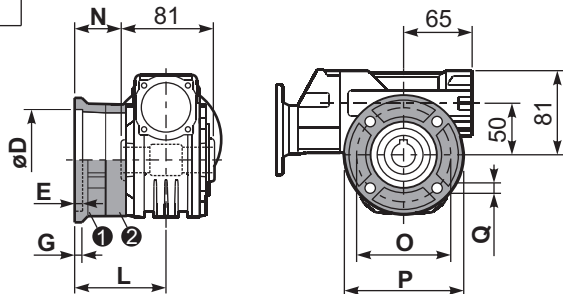

type B	øD	E	G	L	N	O	P	Q	kit code
FC	70 ^{+0.20} / _{+0.15}	9	12	85	44.5	90	123	10.5	① K050.9.010 ② -
FL	70 ^{+0.20} / _{+0.15}	9	12	114.5	74	90	123	10.5	① K050.9.010 ② K050.0.200

PP50.....S... Single Shaft
Albero lento semplice

PP50.....D... Double Shaft
Albero lento bisp.

type S	øD	E	G	L	N	O	P	Q	kit code
F1	110 ^{+0.20} / _{+0.15}	4	11	83.5	43	130	160	10	① KS050.9.012 ② -
F2	70 ^{+0.20} / _{+0.15}	9	12	76.5	36	90	123	10.5	① KS050.9.014 ② -
F3	95 ^{+0.035} / ₀	4	10	66.5	26	115	140	10	① KS050.9.013 ② -

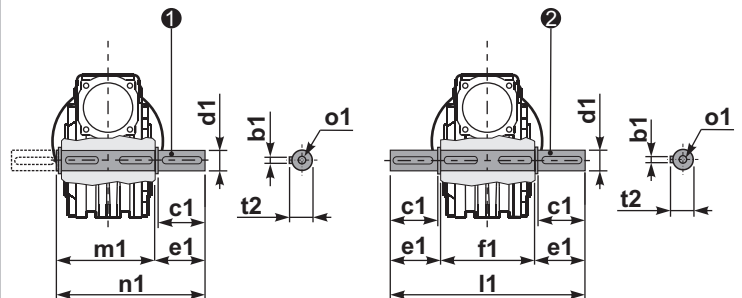

① kit cod. K050.5.028 type B
kit cod. KS050.5.030 type S

② kit cod. K050.5.029 type B
kit cod. KS050.5.031 type S

RP50FB... Input shaft
Albero in entrata

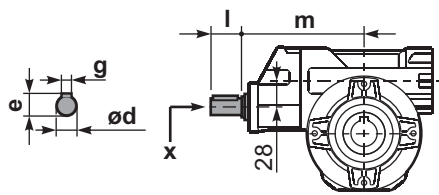

	ød	e	g	l	m	x
type B	14 j6	16	5	25	135.5	M5x13
type S	-	-	-	-	-	-

	b1	c1	d1	e1	f1	l1	m1	n1	t2	o1
type B	8	52	25 ^{-0.005} / _{-0.020}	59.5	81	200	86.5	146	28	M8x20
type S	8	50	24 ^{-0.005} / _{-0.020}	68.8	81	218	86.5	155	27	M8x20

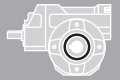

QUICK SELECTION / Selezione veloce

input speed (n_1) = 1400 min⁻¹

	Output Speed n_2 [min ⁻¹]	Ratio i	Motor power P_{1M} [kW]	Output torque M_{2M} [Nm]	Service factor f.s.	Nominal power P_{1R} [kW]	Nominal torque M_{2R} [Nm]	Available B5 motor flanges				Available B14 motor flanges				Dynamic efficiency RD	Tooth Module Mn [mm]	 Ratios code
								B	C	D	E	P	Q	R	T			
								63	71	80	90	63	71	80	90			
IEC 90 - 80 - 71	47	29.9	0.75	113	1.3	0.99	150					C	C		74	2.6	01	
	37	37.7	0.75	141	1.1	0.80	150					C	C		73	2.0	02	
	30	47.1	0.75	169	1.0	0.76	170					C	C		70	3.2	03	
	25	56.6	0.55	136	1.3	0.69	170					C	C		64	2.7	04	
	19.8	70.7	0.37	111	1.5	0.57	170					C	C		62	2.1	05	
	15.9	87.8	0.37	162	1.1	0.39	170					C	C		73	2.6	06	
	12.6	111.0	0.37	199	0.9	0.32	170					C	C		71	2.0	07	
IEC 71 - 63	10.1	139	0.37	234	0.7	0.27	170					C			67	3.2	08	
	8.4	166	0.25	173	1.0	0.25	170					C			61	2.7	09	
	6.7	208	0.18	151	1.0	0.18	150					C			59	2.1	10	
	4.5	310	0.12	129	1.2	0.14	150					C			51	1.5	11	
	3.8	370	0.12	145	1.0	0.12	150					C			48	1.3	12	
	3.2	434	0.12	149	0.8	0.10	125					C			42	1.1	13	

Motor Flanges Available Flange Motore Disponibili
 B) Supplied with Reduction Bushing Fornito con Bussola di Riduzione
 B) Available on Request without reduction bushing Disponibile a Richiesta senza Bussola di Riduzione
 C) Motor Flange Holes Position Posizione Fori Flangia Motore

EN Unit P63 is supplied with synthetic oil, providing "long life" lubrication. For mounting position V5-V6 please contact us. See table 1 for lubrication and recommended quantity. In table 2 please see possible radial loads and axial loads on the gearbox. For complete documentation please visit our web site.

I Il riduttore tipo P63 viene fornito lubrificato a vita con olio sintetico. Per posizioni V5-V6 contattare il ns. servizio tecnico. Vedi tab.1 per oli e quantità consigliati. In tab.2 sono presenti i carichi radiali e assiali applicabili al riduttore. Per la documentazione completa consulta il nostro sito.

D Für die Lebensdauerschmierung ist das Getriebe der Größe P63 mit synthetischem Öl befüllt. Bei Einbaulage V5 oder V6 bitten wir um Rücksprache. In Tabelle 1 ist die Schmiermenge und das empfohlene Schmiermittel angegeben. In Tabelle 2 sind die zulässigen Radial - und Axialbelastungen des Getriebes aufgeführt. Die komplette Dokumentation, Wartungs - und Inbetriebnahmeanleitungen finden Sie unter.

E El reductor tamaño P63 se suministra, lubricado de por vida con aceite sintético. Para las posiciones V5 y V6 contactar con nuestro servicio técnico. Ver tabla 1, para cantidades y aceites recomendados. En la tabla 2, se encuentran las cargas radiales y axiales admitidas por el reductor. Para documentación completa, consultar nuestra Web.

LUBRICATION P63 Oil Quantity 0.40/0.08 Lt.

AGIP	KLUBER	SHELL	MOBIL
Telium VSF 320	Syntheso D220 EP	Tivela Oil WB	Glygoyl 30 SHC 630

tab. 1

RADIAL AND AXIAL LOADS

Output shaft
Albero di uscita

n_2 [min ⁻¹]	FA [N]	FR [N]
75	500	2500
50	600	3000
25	700	3800
15-6	800	4000

Input shaft
albero in entrata

n_1 [min ⁻¹]	FA [N]	FR [N]
1400	61	305

***Strong axial loads in the DX direction are not allowed.**
Non sono consentiti forti carichi assiali con direzione DX

tab. 2

SELECT THIS TYPE AND THIS SPECIFIC SIZE ON THE WEB PAGES TO GET COMPLETE TECHNICAL DATA.
Selezionare tipo e gandezza specifica nel sito web per la documentazione completa.

PP63**FB**... Basic wormbox
Riduttore base

Wormbox weight	29.9+111	139+434
peso riduttore	7.30 Kg	7.80 Kg

M.flange	Kit code	øF	A
71B5	K063.4.042	160	176.5
80/90B5	K063.4.043	200	178.5
71B14	K063.4.047	105	176.5
80B14	K063.4.046	120	177.5
90B14	K063.4.041	140	178.5
<hr/>			
139+434	63B5	K050.4.041	138 160.5
	71B5	K050.4.042	160 158.5
	63B14	K050.4.047	90 160.5
	71B14	K050.4.045	105 160

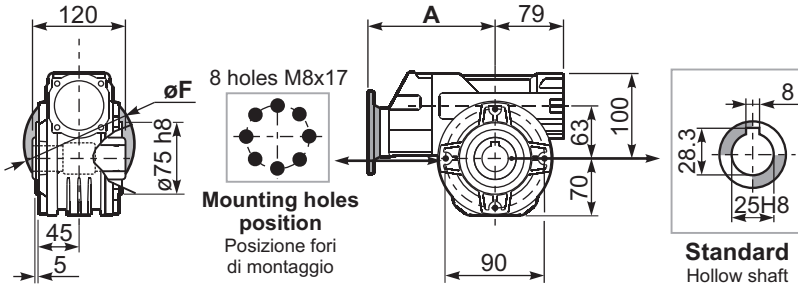

PP63**PA**... Feet
Piedini

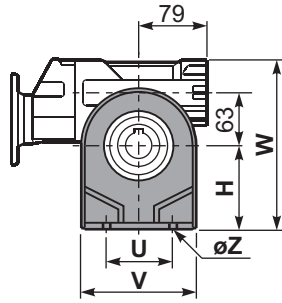
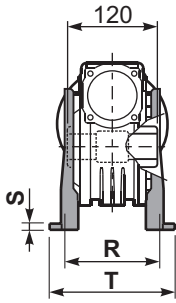

PP63**PB**... Feet
Piedini

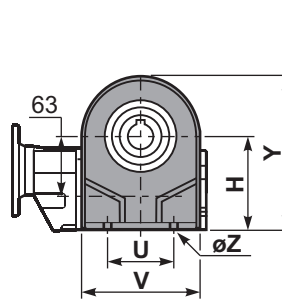

PP63**PV**... Feet
Piedini

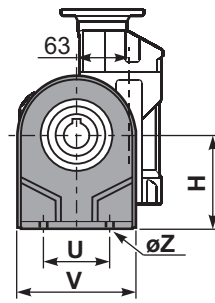

	H	R	S	T	U	V	Y	W	øZ	kit code
type B	100	111	4	144	95	133	170	200	ø10.5	K063.9.022
type S	-	-	-	-	-	-	-	-	-	-

PP63**FC**... Output flange
Flangia uscita

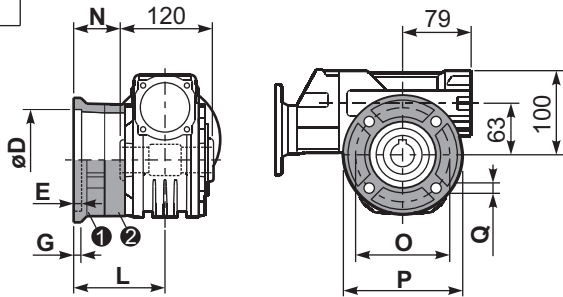

type B	øD	E	G	L	N	O	P	Q	kit code
FC	115 ^{+0.20} / _{+0.15}	7	13	86	26	150	175	11	① K063.9.010 ② -
FL	115 ^{+0.20} / _{+0.15}	7	13	116	56	150	175	11	① K063.9.010 ② K063.0.200
type S	øD	E	G	L	N	O	P	Q	kit code
F1	130 ^{+0.20} / _{+0.15}	7	13	102	42	165	200	13	① KS070.9.013 ② -
F2	115 ^{+0.20} / _{+0.15}	7	13	116	56	150	175	11	① KS063.9.013 ② -
F3	110 ^{+0.035} / ₀	5	11	82	22	130	160	10	① KS063.9.011 ② -

PP63**BR**... Reaction arm
Braccio di reazione

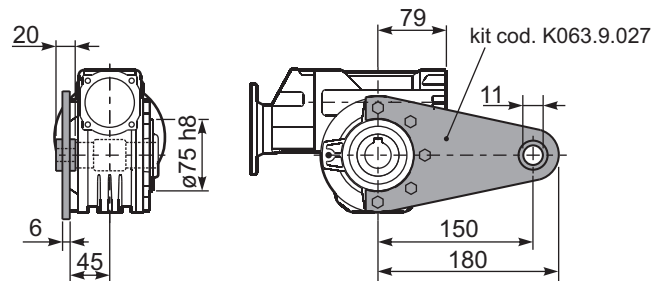

PP63.....**S**... Single Shaft
Albero lento semplice

PP63.....**D**... Double Shaft
Albero lento bisp.

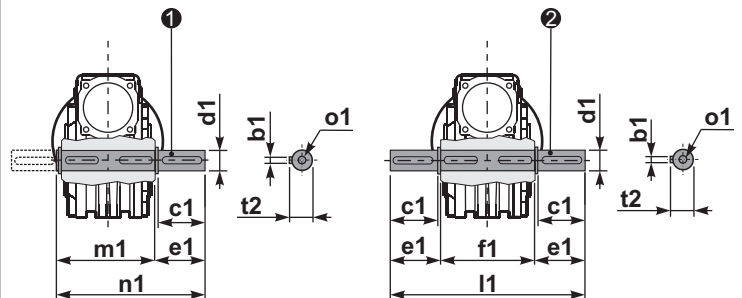

① kit cod. K063.5.028 type B

② kit cod. K063.5.029 type B

RP63**FB**... Input shaft
Albero in entrata

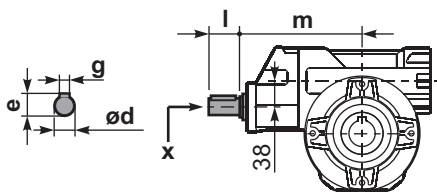

	ød	e	g	l	m	x	
29.9+111	19 j5	21.5	6	35	169.4	M6x16	C40.5.062
139+434	14 j5	16	5	25	154.2	M5x13	C35.5.061

	b1	c1	d1	e1	f1	l1	m1	n1	t2	o1
type B	8	60	25 ^{-0.005} / _{-0.020}	63.2	120	246.4	126.8	190	28	M8x20
type S	-	-	-	-	-	-	-	-	-	-

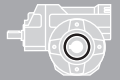

QUICK SELECTION / Selezione veloce

input speed (n₁) = 1400 min⁻¹

	Output Speed n ₂ [min ⁻¹]	Ratio i	Motor power P _{IM} [kW]	Output torque M _{2M} [Nm]	Service factor f.s.	Nominal power P _{1R} [kW]	Nominal torque M _{2R} [Nm]	Available B5 motor flanges				Available B14 motor flanges				Dynamic efficiency RD	Tooth Module Mn [mm]	Ratios code
								B	C	D	E	P	Q	R	T			
								63	71	80	90	63	71	80	90			
IEC 90 - 80 - 71	47	29.9	0.75	113	1.5	1.09	165					C	C		74	2.6	01	
	37	37.7	0.75	141	1.2	0.88	165					C	C		73	2.0	02	
	30	47.1	0.75	169	1.1	0.83	187					C	C		70	3.2	03	
	25	56.6	0.55	136	1.4	0.76	187					C	C		64	2.7	04	
	19.8	70.7	0.37	109	1.7	0.64	187					C	C		61	2.1	05	
	15.9	87.8	0.37	160	1.2	0.46	198					C	C		72	2.6	06	
	12.6	111.0	0.37	196	1.0	0.37	198					C	C		70	2.0	07	
IEC 71 - 63	10.1	139	0.37	231	0.9	0.32	198					C			66	3.2	08	
	8.4	166	0.25	170	1.2	0.29	198					C			60	2.7	09	
	6.7	208	0.25	195	0.9	0.23	176					C			55	2.1	10	
	4.5	310	0.18	194	0.9	0.16	176					C			51	1.5	11	
	3.8	370	0.18	213	0.8	0.15	176					C			47	1.3	12	
	3.2	434	0.18*	130	<0.8	0.10	130					C			42	1.1	13	

Motor Flanges Available
Flange Motore Disponibili

B) Supplied with Reduction Bushing
Fornito con Bussola di Riduzione

B) Available on Request without reduction bushing
Disponibile a Richiesta senza Bussola di Riduzione

C) Motor Flange Holes Position
Posizione Fori Flangia Motore

* Power higher than the maximum one which can be supported by the gearbox. Select according to the torque M_{2R}
Potenza superiore a quella massima sopportabile dal riduttore. Selezionare in base al momento torcente M_{2R}

EN Unit P6A is supplied with synthetic oil, providing "long life" lubrication. For mounting position V5-V6 please contact us. See table 1 for lubrication and recommended quantity. In table 2 please see possible radial loads and axial loads on the gearbox. For complete documentation please visit our web site.

I Il riduttore tipo P6A viene fornito lubrificato a vita con olio sintetico. Per posizioni V5-V6 contattare il ns. servizio tecnico. Vedi tab.1 per oli e quantità consigliati. In tab.2 sono presenti i carichi radiali e assiali applicabili al riduttore. Per la documentazione completa consulta il nostro sito.

D Für die Lebensdauerschmierung ist das Getriebe der Größe P6A mit synthetischem Öl befüllt. Bei Einbaulage V5 oder V6 bitten wir um Rücksprache. In Tabelle 1 ist die Schmiermenge und das empfohlene Schmiermittel angegeben. In Tabelle 2 sind die zulässigen Radial - und Axialbelastungen des Getriebes aufgeführt. Die komplette Dokumentation, Wartungs - und Inbetriebnahmeanleitungen finden Sie unter.

E El reductor tamaño P6A se suministra, lubricado de por vida con aceite sintético. Para las posiciones V5 y V6 contactar con nuestro servicio técnico. Ver tabla 1, para cantidades y aceites recomendados. En la tabla 2, se encuentran las cargas radiales y axiales admitidas por el reductor. Para documentación completa, consultar nuestra Web.

LUBRICATION P63 Oil **Quantity 0.40/0.08 Lt.**

AGIP	KLUBER	SHELL	MOBIL
Telium VSF 320	Syntheso D220 EP	Tivela Oil WB	Glygoyl 30 SHC 630

tab. 1

RADIAL AND AXIAL LOADS

Output shaft
Albero di uscita

n ₂ [min ⁻¹]	FA [N]	FR [N]
75	500	2500
50	600	3000
25	700	3800
15-6	800	4000

Input shaft
albero in entrata

n ₁ [min ⁻¹]	FA [N]	FR [N]
1400	61	305

***Strong axial loads in the DX direction are not allowed.**
Non sono consentiti forti carichi assiali con direzione DX

tab. 2

SELECT THIS TYPE AND THIS SPECIFIC SIZE ON THE WEB PAGES TO GET COMPLETE TECHNICAL DATA.
Selezionare tipo e gandezza specifica nel sito web per la documentazione completa.

PP6A_{FB}... Basic wormbox
Riduttore base

Wormbox weight	29.9+111	139+434
peso riduttore	7.30	7.80
	Kg	Kg

M.flange	Kit code	øF	A
29.9+111	71B5	K063.4.042	160
	80/90B5	K063.4.043	200
	71B14	K063.4.047	105
	80B14	K063.4.046	120
139+434	90B14	K063.4.041	140
	63B5	K050.4.041	138
	71B5	K050.4.042	160
	63B14	K050.4.047	90
71B14	K050.4.045	105	160

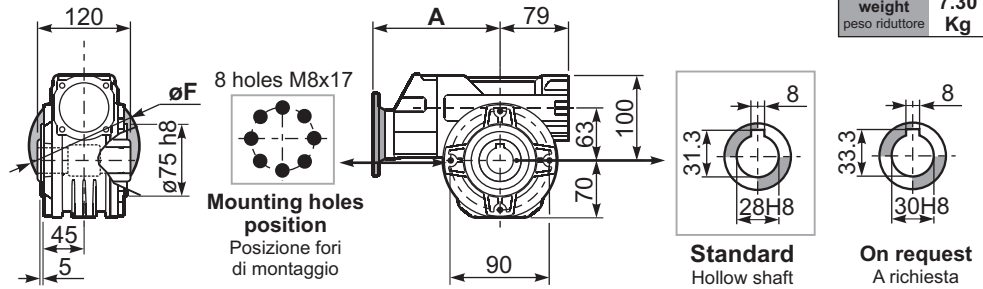

PP6A_{PA}... Feet
Piedini

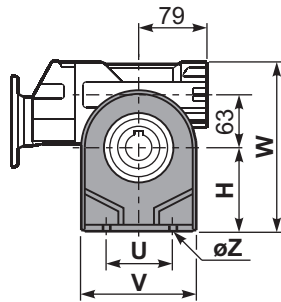
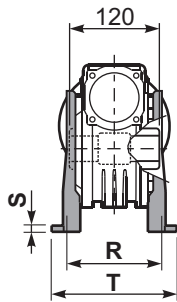

PP6A_{PB}... Feet
Piedini

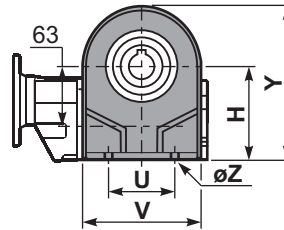

PP6A_{PV}... Feet
Piedini

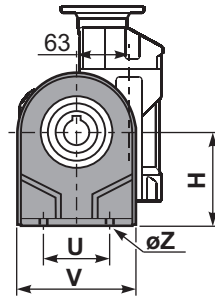

	H	R	S	T	U	V	Y	W	øZ	kit code
type B	115	115	12	142	120	156	185	215	ø11	K070.9.022
type S	-	-	-	-	-	-	-	-	-	-

PP6A_{FC}... Output flange
Flangia uscita

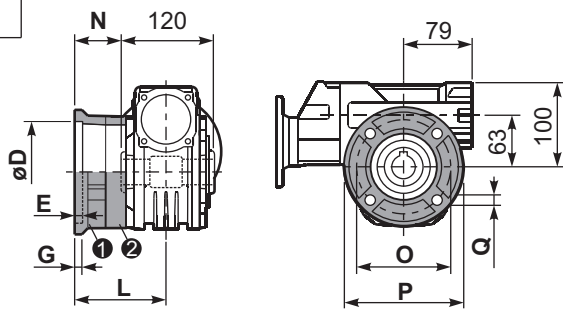

type B	øD	E	G	L	N	O	P	Q	kit code
FC	130 ^{+0.20} / _{+0.15}	7	13	85	25	165	200	13	① K070.9.010 ② -
FL	130 ^{+0.20} / _{+0.15}	7	13	111	51	165	200	13	① K070.9.010 ② K070.0.200

type S	øD	E	G	L	N	O	P	Q	kit code
F1	130 ^{+0.20} / _{+0.15}	7	13	111	51	165	200	13	① KS070.9.014 ② -
F2	115 ^{+0.20} / _{+0.15}	7	13	116	56	150	175	11	① KS063.9.013 ② -
F3	110 ^{+0.035} / ₀	5	13.5	84.5	24.5	130	160	11	① KS070.9.011 ② -

PP6A_{BR}... Reaction arm
Braccio di reazione

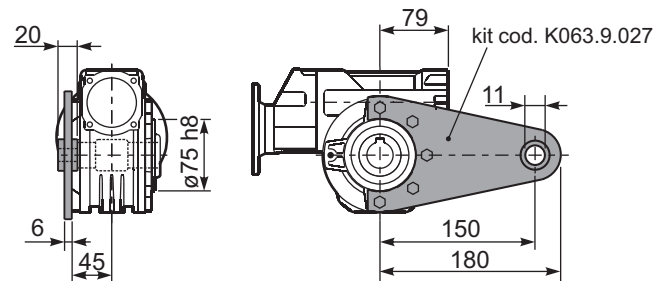

PP6A.....S... Single Shaft
Albero lento semplice

PP6A.....D... Double Shaft
Albero lento bisp.

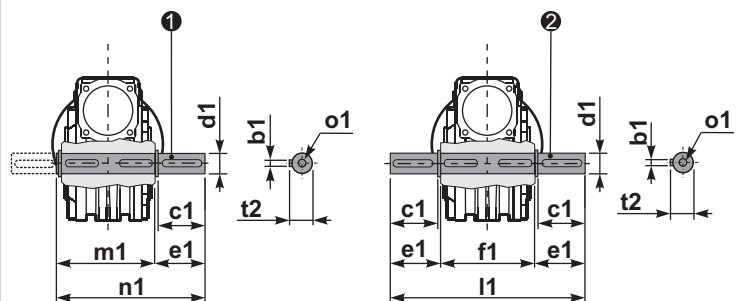

① kit cod. K070.5.028 type B

② kit cod. K070.5.029 type B

R_{P6}AFB... Input shaft
Albero in entrata

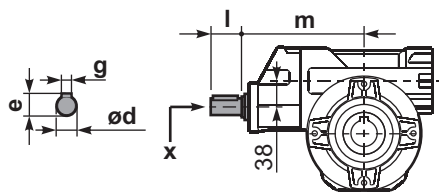

	ød	e	g	l	m	x	
29.9+111	19 j5	21.5	6	35	169.4	M6x16	C40.5.062
139+434	14 j5	16	5	25	154.2	M5x13	C35.5.061

	b1	c1	d1	e1	f1	l1	m1	n1	t2	o1
type B	8	60	28 ^{-0.005} / _{-0.020}	63.5	120	247	127.5	191	31	M8x20
type S	-	-	-	-	-	-	-	-	-	-

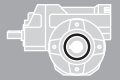

QUICK SELECTION / Selezione veloce

input speed (n_1) = 1400 min⁻¹

Output Speed n_2 [min ⁻¹]	Ratio i	Motor power P_{1M} [kW]	Output torque M_{2M} [Nm]	Service factor f.s.	Nominal power P_{1R} [kW]	Nominal torque M_{2R} [Nm]	Available B5 motor flanges				Available B14 motor flanges			Dynamic efficiency RD	Tooth Module Mn [mm]	Ratios code
							B	C	D	E	Q	R	T			
							63	71	80	90	71	80	90			
23.5	59.7	1.1	300	1.3	1.39	380					C	C		67	3.5	01
19.4	72.3	1.1	347	1.1	1.17	370					C	C		64	3.1	02
17.1	81.7	1.1	374	1.0	1.12	380					C	C		61	2.7	03
13.3	105	0.75	323	1.1	0.81	350					C	C		60	2.1	04
8.0	176	0.55	415	1.0	0.53	400	B				C	C		63	3.5	05
6.6	213	0.37	322	1.1	0.43	370	B				C	C		60	3.1	06
5.8	240	0.37	321	1.2	0.44	380	B				C	C		53	2.7	07
4.3	328	0.37	438	0.9	0.32	380	B				C	C		53	2.7	08
3.3	422	0.25	374	0.9	0.23	350	B				C	C		52	2.1	09
3.0	466	0.25	358	0.8	0.21	300	B				C	C		45	1.9	10
2.3	605	0.18	297	1.0	0.18	300	B				C	C		40	1.5	11

Motor Flanges Available
Flange Motore Disponibili

B) Supplied with Reduction Bushing
Fornito con Bussola di Riduzione

B) Available on Request without reduction bushing
Disponibile a Richiesta senza Bussola di Riduzione

C) Motor Flange Holes Position
Posizione Fori Flangia Motore

EN Unit P85 is supplied with synthetic oil, providing "long life" lubrication. For mounting position V5-V6 please contact us. See table 1 for lubrication and recommended quantity. In table 2 please see possible radial loads and axial loads on the gearbox. For complete documentation please visit our web site.

I Il riduttore tipo P85 viene fornito lubrificato a vita con olio sintetico. Per posizioni V5-V6 contattare il ns. servizio tecnico. Vedi tab.1 per oli e quantità consigliati. In tab.2 sono presenti i carichi radiali e assiali applicabili al riduttore. Per la documentazione completa consulta il nostro sito.

D Für die Lebensdauerschmierung ist das Getriebe der Größe P85 mit synthetischem Öl befüllt. Bei Einbaulage V5 oder V6 bitten wir um Rücksprache. In Tabelle 1 ist die Schmiermenge und das empfohlene Schmiermittel angegeben. In Tabelle 2 sind die zulässigen Radial- und Axialbelastungen des Getriebes aufgeführt. Die komplette Dokumentation, Wartungs- und Inbetriebnahmeanleitungen finden Sie unter.

E El reductor tamaño P85 se suministra, lubricado de por vida con aceite sintético. Para las posiciones V5 y V6 contactar con nuestro servicio técnico. Ver tabla 1, para cantidades y aceites recomendados. En la tabla 2, se encuentran las cargas radiales y axiales admitidas por el reductor. Para documentación completa, consultar nuestra Web.

LUBRICATION P85 Oil Quantity 1.20/0.14 Lt.

AGIP	KLUBER	SHELL	MOBIL
Telium VSF 320	Syntheso D220 EP	Tivela Oil WB	Glygoyl 30 SHC 630

tab. 1

RADIAL AND AXIAL LOADS

Output shaft
Albero di uscita

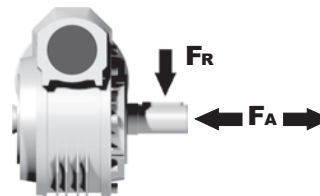

n_2 [min ⁻¹]	FA [N]	FR [N]
75	700	3500
50	800	4000
25	1000	5000
15-6	1160	5800

Input shaft
albero in entrata

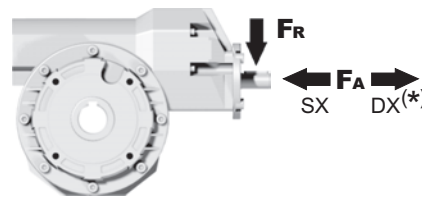

n_1 [min ⁻¹]	FA [N]	FR [N]
1400	108	540

***Strong axial loads in the DX direction are not allowed.**
Non sono consentiti forti carichi assiali con direzione DX

tab. 2

SELECT THIS TYPE AND THIS SPECIFIC SIZE ON THE WEB PAGES TO GET COMPLETE TECHNICAL DATA.
Selezionare tipo e gandezza specifica nel sito web per la documentazione completa.

PP85**FB**... Basic wormbox
Riduttore base

Wormbox weight
peso riduttore **19.30 kg**

M. flanges	Kit code	øF	A
63B5	K063.4.041	140	195.2
71B5	K063.4.042	160	193.2
80/90B5	K063.4.043	200	195.2
71B14	K063.4.047	105	193.2
80B14	K063.4.046	120	194.2
90B14	K063.4.041	140	195.2

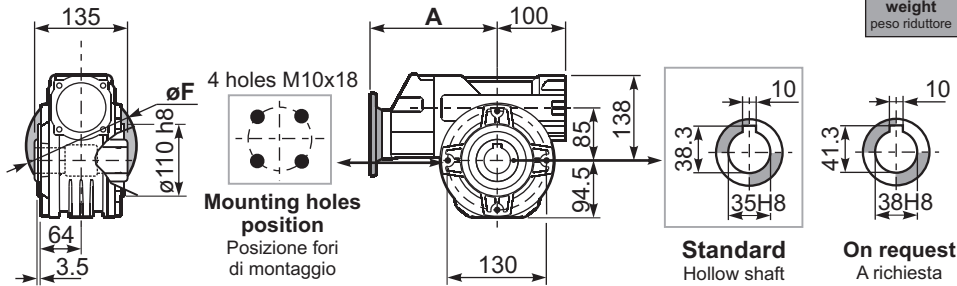

PP85**PA**... Feet
Piedini

PP85**PB**... Feet
Piedini

PP85**PV**... Feet
Piedini

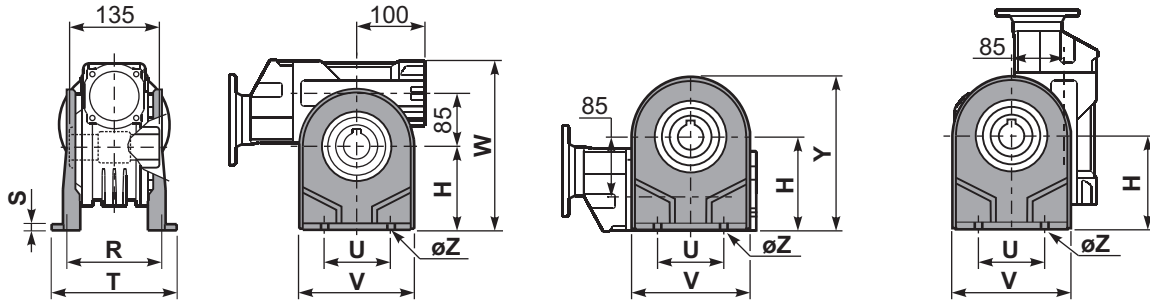

	H	R	S	T	U	V	Y	W	øZ	kit code
type B	142	145	5	182	140	180	236.5	280	ø10.5	K085.9.022
type S	-	-	-	-	-	-	-	-	-	-

PP85**FC**... Output flange
Flangia uscita

PP85**BR**... Reaction arm
Braccio di reazione

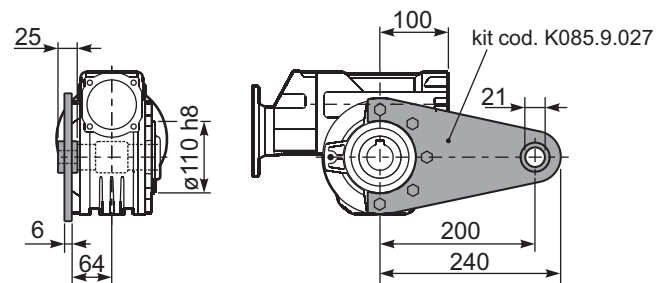
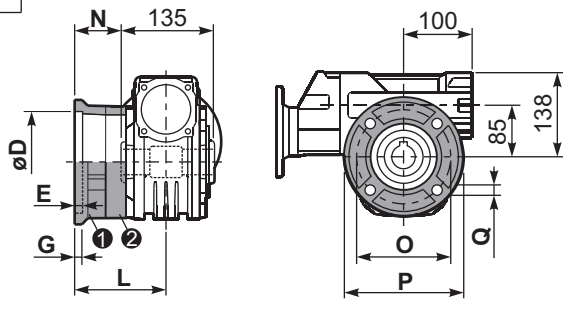

type B	øD	E	G	L	N	O	P	Q	kit code
FC	152 ^{+0.06} / _{+0.00}	5	16	108	40.5	176	205	13	① K085.9.010 ② -
FL	152 ^{+0.06} / _{+0.00}	5	16	148.5	81	176	205	13	① K085.9.010 ② K085.0.201

type S	øD	E	G	L	N	O	P	Q	kit code
F1	130 ^{+0.04} / _{+0.00}	5	13	117.5	50	165	200	11.5	① KS085.9.012 ② -
F2	152 ^{+0.06} / _{+0.00}	5	15	147.5	80	180	205	12.5	① KS085.9.013 ② -
F4	130 ^{+0.04} / _{+0.00}	5	13	106.5	39	165	200	13	① KS085.9.015 ② -

PP85.....**S**... Single Shaft
Albero lento semplice

PP85.....**D**... Double Shaft
Albero lento bisp.

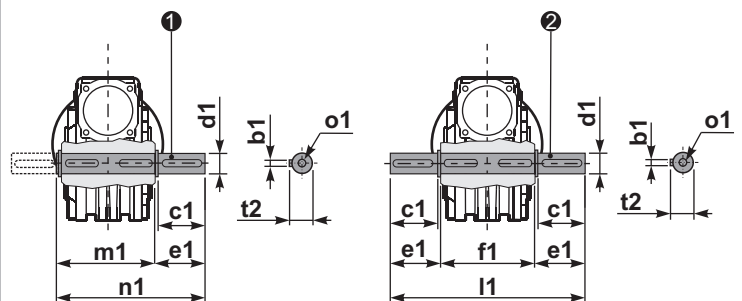

① kit cod. K085.5.028 type B

② kit cod. K085.5.029 type B

RP85**FB**... Input shaft
Albero in entrata

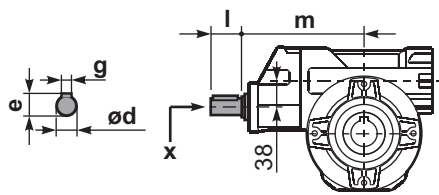

	ød	e	g	l	m	x	
type B	19 j5	21.5	6	35	187.5	M6x16	C40.5.062
type S	-	-	-	-	-	-	-

	b1	c1	d1	e1	f1	l1	m1	n1	t2	o1
type B	10	60	35 ^{-0.005} / _{-0.020}	73.5	135	282	141	214.5	38	M10x23
type S	-	-	-	-	-	-	-	-	-	-

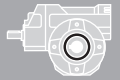

QUICK SELECTION / Selezione veloce

input speed (n_1) = 1400 min⁻¹

Output Speed n_2 [min ⁻¹]	Ratio i	Motor power P_{1M} [kW]	Output torque M_{2M} [Nm]	Service factor f.s.	Nominal power P_{1R} [kW]	Nominal torque M_{2R} [Nm]	Available B5 motor flanges				Available B14 motor flanges			Dynamic efficiency RD	Tooth Module M_n [mm]	Ratios code
							B	C	D	E	Q	R	T			
							63	71	80	90	71	80	90			
16.8	83.2	1.5	562	1.1	1.6	600					C			69	3.5	01
13.9	100.5	1.5	651	0.8	1.2	540					C			68	2.9	02
10.6	132	1.1	574	0.9	1.0	500					C			64	2.2	03
8.0	176	0.75	594	1.2	0.92	730	B				C			74	4.7	04
6.7	208	0.75	670	0.9	0.67	600	B				C			72	4.0	05
5.7	245	0.55	570	1.1	0.58	600	B				C			69	3.5	06
4.7	296	0.55	611	0.9	0.49	540	B				C			68	2.9	07
4.2	334	0.55	689	0.9	0.48	600	B				C			69	3.5	08
3.5	403	0.37	519	1.0	0.39	540	B				C			68	2.9	09
2.6	529	0.25	424	1.2	0.29	500	B				C			64	2.2	10
2.2	624	0.25	479	1.0	0.25	480	B				C			59	1.9	11

Motor Flanges Available
Flange Motore Disponibili

B) Supplied with Reduction Bushing
Fornito con Bussola di Riduzione

B) Available on Request without reduction bushing
Disponibile a Richiesta senza Bussola di Riduzione

C) Motor Flange Holes Position
Posizione Fori Flangia Motore

EN Unit P10 is supplied without lubricant and equipped with a breather, level and drain plugs. User can add mineral oil keeping existing plugs. Should the user wish to fill it with synthetic oil, it is recommended to replace the existing plugs with a closed plug. Primary reduction unit is supplied with closed plugs and lubricated for life with synthetic oil. See table 1 for lubrication and recommended quantity. In table 2 please see possible radial loads and axial loads on the gearbox. For complete documentation please visit our web site.

B3	B6	B7	B8	V5	V6
2.0/0.14LT	1.5/0.14 LT	1.5/0.14 LT	2.0/0.14 LT	2.0/0.14 LT	2.0/0.14 LT
AGIP	BP	SHELL	KLUBER	MOBIL	
Telium VSF 320	Energol SGXP220	Tivela Oil WB	Syntheso D220 EP	Glygoyl 30	

tab. 1

I Il riduttore tipo P10 è fornito privo di lubrificazione con tappi di sfiato, livello e scarico olio. L'utente può immettere olio minerale mantenendo i tappi esistenti. Se immetterà olio sintetico, dovrà sostituire i tappi esistenti con altri tipo chiuso. La precoppia è fornita con tappi chiusi e lubrificata a vita con olio sintetico. Tab.1 per oli e quantità consigliati. Tab.2 carichi radiali e assiali applicabili al riduttore. Per la documentazione completa consulta il nostro sito.

D Das Getriebe der Baugröße P10 wird ohne Schmiermittel geliefert. Es ist jedoch mit Einfüllschraube, Überdruckventil und Ablassschraube ausgerüstet. Das benötigte mineralische Öl kann über die Einfüllschraube eingefüllt werden. Sollte synthetisches Öl bevorzugt werden, so ist sind das eingebaute Überdruckventil durch eine geschlossenen Schraube zu ersetzen. Die Stirnradvorstufe ist Lebensdauer geschmiert und wird mit synthetischem Öl geliefert. Die Stirnradvorstufe ist komplett geschlossen ohne Füllschrauben. In Tabelle 1 ist die Schmiermenge und das empfohlene Schmiermittel angegeben. In Tabelle 2 sind die zulässigen Radial- und Axialbelastungen des Getriebes aufgeführt. Die komplette Dokumentation, Wartungs- und Inbetriebnahmeanleitungen finden Sie unter.

E El reductor tamaño P10 se suministra sin lubricante, provisto de tapones de respiración, nivel y descarga de aceite. El usuario puede utilizar aceite mineral, manteniendo los tapones existentes. Si prefiere utilizar aceite sintético deberá sustituir los tapones existentes por tapones ciegos. La prerreducción se suministra con tapones ciegos, lubricado de por vida con aceite sintético. Ver tabla 1, para cantidades y aceites recomendados. En la tabla 2, se encuentran las cargas radiales y axiales admitidas por el reductor. Para documentación completa, consultar nuestra Web.

RADIAL AND AXIAL LOADS

Output shaft
Albero di uscita

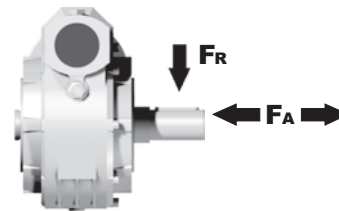

n_2 [min ⁻¹]	FA [N]	FR [N]
75	800	4000
50	920	4600
25	1200	6000
15-6	1400	7000

Input shaft
albero in entrata

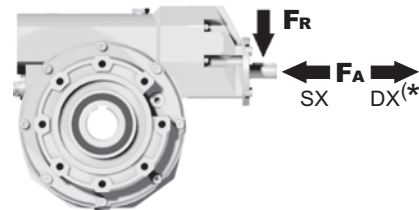

n_1 [min ⁻¹]	FA [N]	FR [N]
1400	150	760

***Strong axial loads in the DX direction are not allowed.**
Non sono consentiti forti carichi assiali con direzione DX

tab. 2

SELECT THIS TYPE AND THIS SPECIFIC SIZE ON THE WEB PAGES TO GET COMPLETE TECHNICAL DATA.
Selezionare tipo e gandezza specifica nel sito web per la documentazione completa.

PP10FB... Basic wormbox
Riduttore base

Wormbox weight
peso riduttore **41.00 kg**

M. flanges	Kit code	øF	A
63B5	K063.4.041	140	214.7
71B5	K063.4.042	160	212.7
80/90B5	K063.4.043	200	214.7
71B14	K063.4.047	105	212.7
80B14	K063.4.046	120	213.7
90B14	K063.4.041	140	214.7

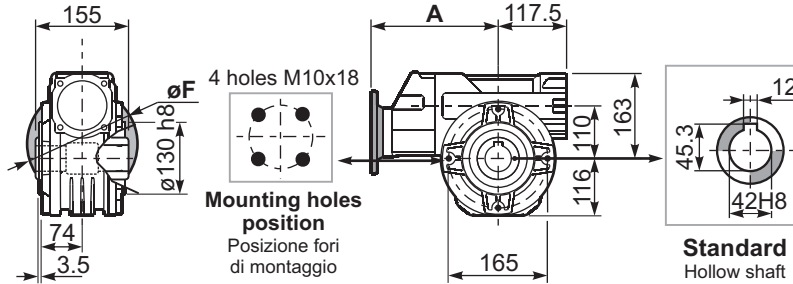

PP10PA... Feet
Piedini

PP10PB... Feet
Piedini

PP10PV... Feet
Piedini

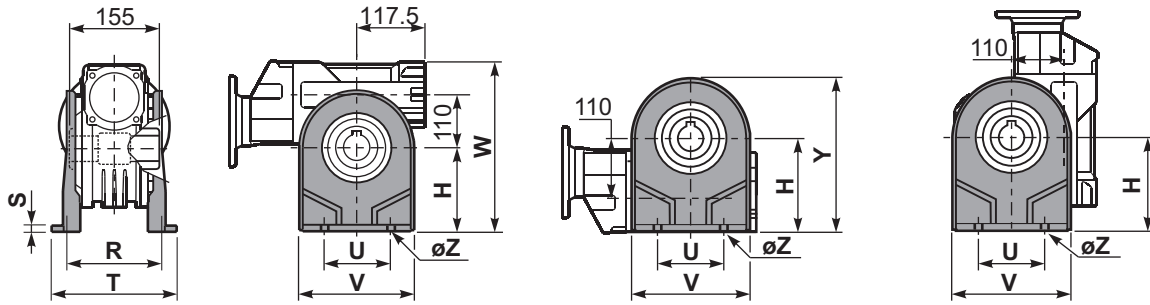

	H	R	S	T	U	V	Y	W	øZ	kit code
type B	170	180	22	224	200	240	286	333	ø13	K110.9.022
type S	172	160	18	190	200	240	288	335	ø14	KS110.9.023

PP10FC... Output flange
Flangia uscita

PP10BR... Reaction arm
Braccio di reazione

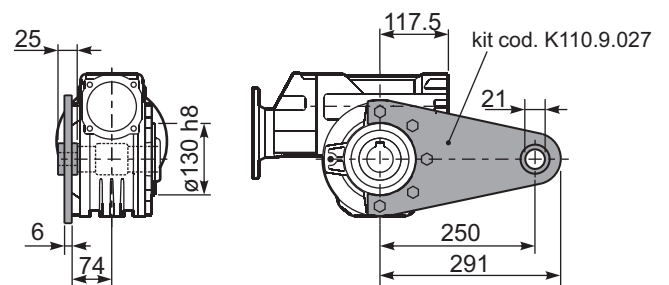
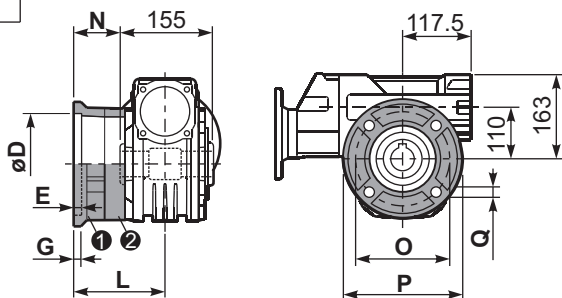

type B	øD	E	G	L	N	O	P	Q	kit code
FC	170 ^{+0.083} / ₀ ^{+0.043}	11	16.5	131.5	54	230	270	13	① K110.9.010 ② -
FL	170 ^{+0.083} / ₀ ^{+0.043}	11	16.5	179.5	102	230	270	13	① K110.9.011 ② -

type S	øD	E	G	L	N	O	P	Q	kit code
F1	180 ^{+0.040} / ₀	5	18	150	72.5	215	250	15	① KS110.9.014 ② -
F2	170 ^{+0.083} / ₀ ^{+0.043}	9.5	15	178	100.5	230	270	13	① KS110.9.012 ② -
F3	180 ^{+0.040} / ₀	5	18	130	52.5	215	250	15	① KS110.9.013 ② -

PP10.....S... Single Shaft
Albero lento semplice

PP10.....D... Double Shaft
Albero lento bisp.

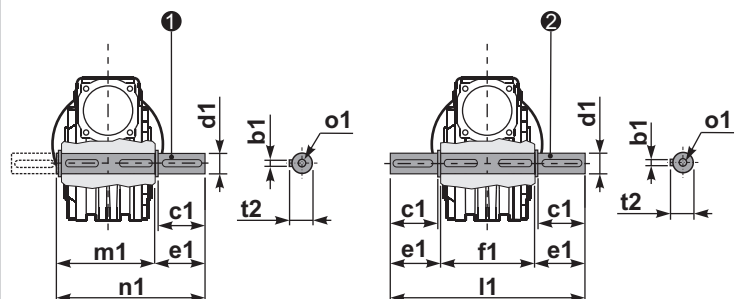

① kit cod. K110.5.028 type B

② kit cod. K110.5.029 type B

RP10FB... Input shaft
Albero in entrata

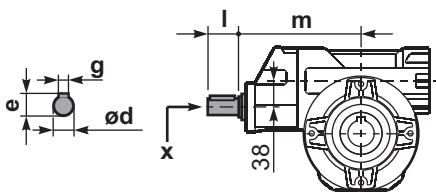

	ød	e	g	l	m	x
type B	19 j5	21.5	6	35	205	M6x16
type S	-	-	-	-	-	-

	b1	c1	d1	e1	f1	l1	m1	n1	t2	o1
type B	12	75	42 ^{-0.005} / ₀ ^{-0.020}	96.5	155	348	163.5	260	45	M12x32
type S	-	-	-	-	-	-	-	-	-	-

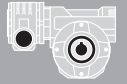

QUICK SELECTION / Selezione veloce							input speed (n ₁) = 1400 min ⁻¹						
Output Speed n ₂ [min ⁻¹]	Ratio i	Motor power P _{1M} [kW]	Output torque M _{2M} [Nm]	Service factor f.s.	Nominal power P _{1R} [kW]	Nominal torque M _{2R} [Nm]	Available B5 motor flanges		Available B14 motor flanges		Dynamic efficiency RD	Tooth Module Mn [mm]	Ratios code
							A	B	O	P			
9.3	150	0.06	29	1.0	0.06	30	B		B-C		48	1.44	01
6.7	210	0.06	39	0.8	0.05	30	B		B-C		45	1.44	02
4.7	300	0.06*	30	<0.8	0.04	30	B		B-C		36	1.44	03
3.1	450	0.06*	30	<0.8	0.03	30	B		B-C		33	1.44	04
2.3	600	0.06*	30	<0.8	0.02	30	B		B-C		30	1.44	05
1.6	900	0.06*	30	<0.8	0.02	30	B		B-C		27	1.44	06
1.2	1200	0.06*	30	<0.8	0.01	30	B		B-C		26	1.44	07
0.8	1830	0.06*	30	<0.8	0.01	30	B		B-C		24	1.44	08
0.6	2400	0.06*	30	<0.8	0.01	30	B		B-C		22	1.44	09

A) Motor Flanges Available
Flange Motore Disponibili

B) Supplied with Reduction Bushing
Fornito con Bussola di Riduzione

B) Available on Request without reduction bushing
Disponibile a Richiesta senza Bussola di Riduzione

C) Motor Flange Holes Position
Posizione Fori Flangia Motore

* Power higher than the maximum one which can be supported by the gearbox. Select according to the torque M_{2R}
Potenza superiore a quella massima sopportabile dal riduttore. Selezionare in base al momento torcente M_{2R}

EN Unit 303 is supplied with synthetic oil, providing "long life" lubrication. For mounting position V5-V6 please contact us. See table 1 for lubrication and recommended quantity. In table 2 please see possible radial loads and axial loads on the gearbox. For complete documentation please visit our web site.

I Il riduttore tipo 303 viene fornito lubrificato a vita con olio sintetico. Per posizioni V5-V6 contattare il ns. servizio tecnico. Vedi tab.1 per oli e quantità consigliati. In tab.2 sono presenti i carichi radiali e assiali applicabili al riduttore. Per la documentazione completa consulta il nostro sito.

D Für die Lebensdauerschmierung ist das Getriebe der Größe 303 mit synthetischem Öl befüllt. Bei Einbaulage V5 oder V6 bitten wir um Rücksprache. In Tabelle 1 ist die Schmiermenge und das empfohlene Schmiermittel angegeben. In Tabelle 2 sind die zulässigen Radial- und Axialbelastungen des Getriebes aufgeführt. Die komplette Dokumentation, Wartungs- und Inbetriebnahmeanleitungen finden Sie unter.

E El reductor tamaño 303 se suministra, lubricado de por vida con aceite sintético. Para las posiciones V5 y V6 contactar con nuestro servicio técnico. Ver tabla 1, para cantidades y aceites recomendados. En la tabla 2, se encuentran las cargas radiales y axiales admitidas por el reductor. Para documentación completa, consultar nuestra Web.

LUBRICATION 303 Oil Quantity 0.03/0.03 Lt.			
AGIP	KLUBER	SHELL	MOBIL
Telium VSF 320	Syntheso D220 EP	Tivela Oil WB	Glygoyl 30 SHC 630

tab. 1

RADIAL AND AXIAL LOADS			
Output shaft Albero di uscita			
	n ₂ [min ⁻¹]	FA [N]	FR [N]
	25	300	1800
	15	400	2000
Input shaft albero in entrata			
	n ₁ [min ⁻¹]	FA [N]	FR [N]
	1400	20	100
	*Strong axial loads in the DX direction are not allowed. Non sono consentiti forti carichi assiali con direzione DX		

tab. 2

SELECT THIS TYPE AND THIS SPECIFIC SIZE ON THE WEB PAGES TO GET COMPLETE TECHNICAL DATA.
Selezionare tipo e gandezza specifica nel sito web per la documentazione completa.

3D dimensions on request

P303FB... Basic wormbox
Riduttore base

Wormbox weight
peso riduttore **2.15 kg**

M. flanges	Kit code	øF	A
56B5	K030.4.041	120	61.5
63B5	K030.4.042	140	62.5
56B14	K030.4.046	80	61.5
63B14	K030.4.045	90	62.5

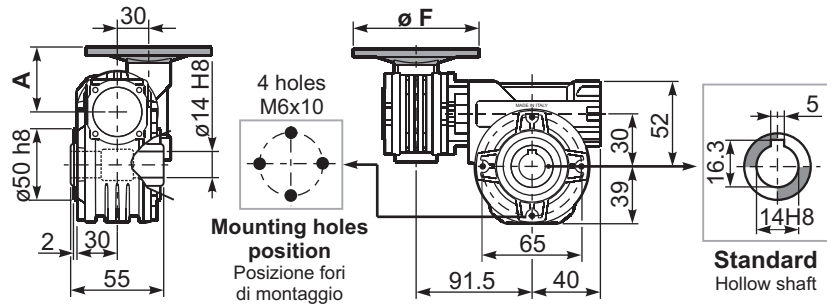

P303PA... Feet
Piedini

P303PB... Feet
Piedini

P303PV... Feet
Piedini

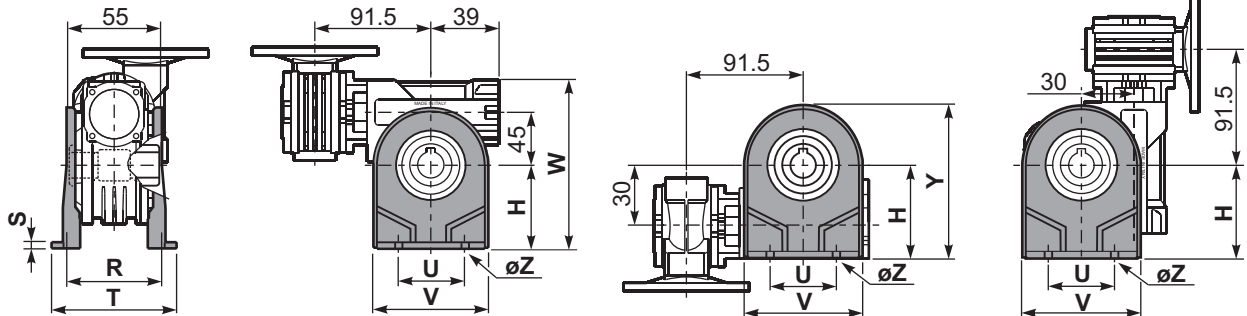

	H	R	S	T	U	V	Y	W	øZ	kit code
type B	55	66	3	87	50	78	94	107	ø6.5	K030.9.022
type S	52	66	3	87	52	90	91	104	ø6.5	KS030.9.023

P303FC... Output flange
Flangia uscita

P303BR... Reaction arm
Braccio di reazione

kit cod. K045.9.027

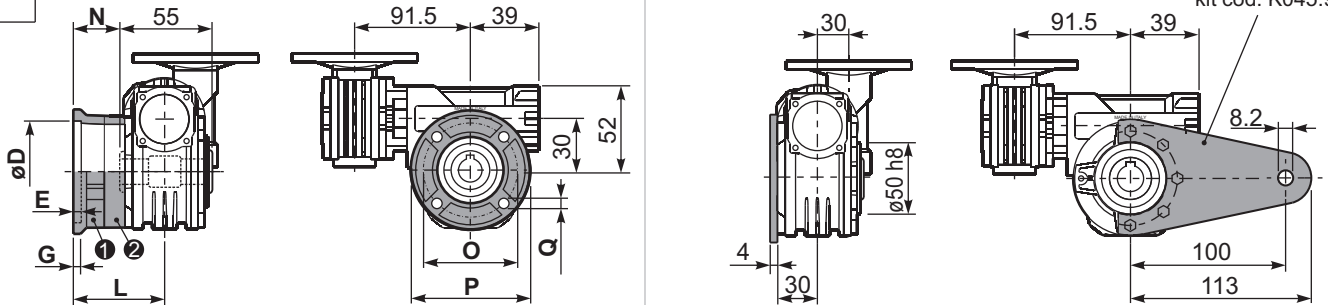

type B	øD	E	G	L	N	O	P	Q	kit code
FC	50 ^{+0.15} / _{+0.05}	6	6	50.5	23	68	80	7	① K030.9.010 ② -
FL	60 ^{+0.15} / _{+0.05}	6	6	55.5	28	87	110	8.5	① K030.9.011 ② -
type S	øD	E	G	L	N	O	P	Q	kit code
F1	40 ^{+0.15} / _{+0.10}	3.5	5.5	49	21.5	56	80	6.5	① KS030.9.012 ② -

P303....S... Single Shaft
Albero lento semplice

P303....D... Double Shaft
Albero lento bisp.

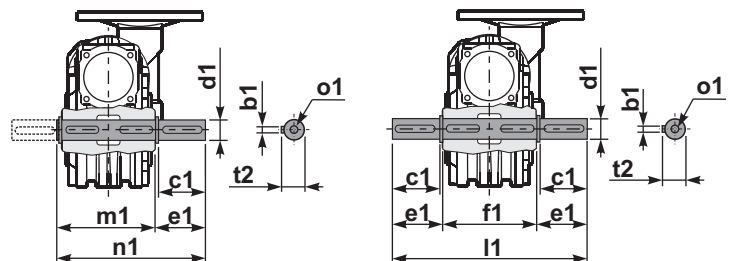

① kit cod. K030.5.028 type B

② kit cod. K030.5.029 type B

R303FB... Input shaft
Albero in entrata

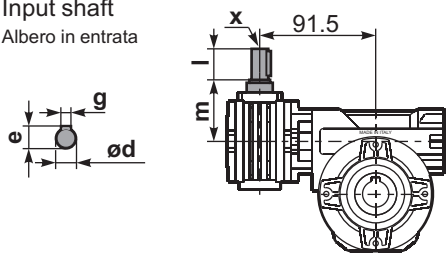

	ød	e	g	l	m	x	kit code
type B	9 h6	10.2	3	20	58	-	K030.5.006 PAM63
type S	-	-	-	-	-	-	-

	b1	c1	d1	e1	f1	l1	m1	n1	t2	o1
type B	5	25	14 ^{-0.005} / _{-0.020}	35.5	55	126	59	94.5	15.8	M5x14
type S	-	-	-	-	-	-	-	-	-	-

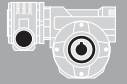

QUICK SELECTION / Selezione veloce

input speed (n_1) = 1400 min⁻¹

Output Speed n_2 [min ⁻¹]	Ratio i	Motor power P_{1M} [kW]	Output torque M_{2M} [Nm]	Service factor f.s.	Nominal power P_{1R} [kW]	Nominal torque M_{2R} [Nm]	Available B5 motor flanges		Available B14 motor flanges		Dynamic efficiency RD	Tooth Module M_n [mm]	Ratios code
							A	B	O	P			
							56	63	56	63			
10.0	140	0.12	57	1.0	0.13	60	B		B-C		50	2.2	01
7.0	200	0.12	79	0.8	0.09	60	B		B-C		48	2.2	02
5.0	280	0.12*	60	<0.8	0.07	60	B		B-C		45	2.4	03
3.3	420	0.12*	60	<0.8	0.06	60	B		B-C		36	1.6	04
2.5	560	0.12*	60	<0.8	0.05	60	B		B-C		33	2.5	05
1.9	740	0.12*	60	<0.8	0.04	60	B		B-C		30	1.8	06
1.5	920	0.12*	60	<0.8	0.04	60	B		B-C		27	1.5	07
1.3	1120	0.12*	60	<0.8	0.03	60	B		B-C		26	2.5	08
0.9	1480	0.12*	60	<0.8	0.02	60	B		B-C		24	1.8	09
0.8	1840	0.12*	60	<0.8	0.02	60	B		B-C		22	1.5	10
0.6	2400	0.12*	60	<0.8	0.02	60	B		B-C		21	1.2	11

A) Motor Flanges Available
Flange Motore Disponibili

B) Supplied with Reduction Bushing
Fornito con Bussola di Riduzione

B) Available on Request without reduction bushing
Disponibile a Richiesta senza Bussola di Riduzione

C) Motor Flange Holes Position
Posizione Fori Flangia Motore

* Power higher than the maximum one which can be supported by the gearbox. Select according to the torque M_{2R}
Potenza superiore a quella massima sopportabile dal riduttore. Selezionare in base al momento torcente M_{2R}

EN Unit 453 is supplied with synthetic oil, providing "long life" lubrication. For mounting position V5-V6 please contact us. See table 1 for lubrication and recommended quantity. In table 2 please see possible radial loads and axial loads on the gearbox. For complete documentation please visit our web site.

I Il riduttore tipo 453 viene fornito lubrificato a vita con olio sintetico. Per posizioni V5-V6 contattare il ns. servizio tecnico. Vedi tab.1 per oli e quantità consigliati. In tab.2 sono presenti i carichi radiali e assiali applicabili al riduttore. Per la documentazione completa consulta il nostro sito.

D Für die Lebensdauerschmierung ist das Getriebe der Größe 453 mit synthetischem Öl befüllt. Bei Einbaulage V5 oder V6 bitten wir um Rücksprache. In Tabelle 1 ist die Schmiermenge und das empfohlene Schmiermittel angegeben. In Tabelle 2 sind die zulässigen Radial- und Axialbelastungen des Getriebes aufgeführt. Die komplette Dokumentation, Wartungs- und Inbetriebnahmeanleitungen finden Sie unter.

E El reductor tamaño 453 se suministra, lubricado de por vida con aceite sintético. Para las posiciones V5 y V6 contactar con nuestro servicio técnico. Ver tabla 1, para cantidades y aceites recomendados. En la tabla 2, se encuentran las cargas radiales y axiales admitidas por el reductor. Para documentación completa, consultar nuestra Web.

LUBRICATION 453 Oil
Quantity 0.09/0.06 Lt.

AGIP	KLUBER	SHELL	MOBIL
Telium VSF 320	Syntheso D220 EP	Tivela Oil WB	Glygoyl 30 SHC 630

tab. 1

RADIAL AND AXIAL LOADS

Output shaft
Albero di uscita

n_2 [min ⁻¹]	FA [N]	FR [N]
25	300	1800
15	400	2000

Input shaft
albero in entrata

n_1 [min ⁻¹]	FA [N]	FR [N]
1400	20	100

*Strong axial loads in the DX direction are not allowed.
Non sono consentiti forti carichi assiali con direzione DX

tab. 2

SELECT THIS TYPE AND THIS SPECIFIC SIZE ON THE WEB PAGES TO GET COMPLETE TECHNICAL DATA.
Selezionare tipo e gandezza specifica nel sito web per la documentazione completa.

3D dimensions on request

P453FB... Basic wormbox
Riduttore base

M. flanges	Kit code	øF	A
56B5	K030.4.041	120	61.5
63B5	K030.4.042	140	62.5
56B14	K030.4.046	80	61.5
63B14	K030.4.045	90	62.5

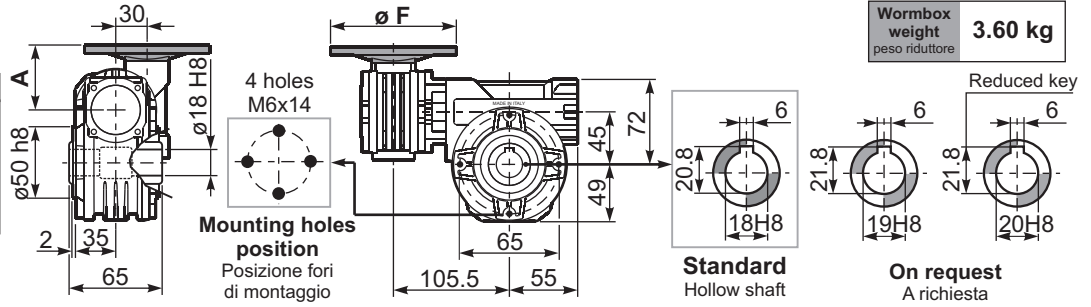

P453PA... Feet
Piedini

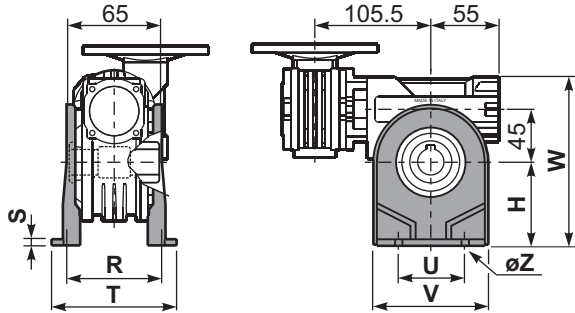

P453PB... Feet
Piedini

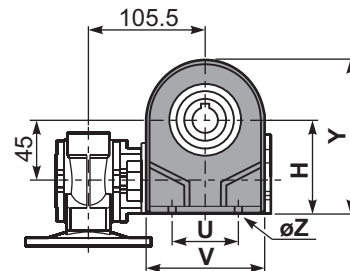

P453PV... Feet
Piedini

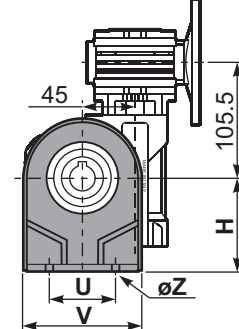

	H	R	S	T	U	V	Y	W	øZ	kit code
type B	72	81	3	100	52	98	121	144	ø10.5	K045.9.022
type S	71	84	8	100	70	90	120	143	ø8	KS045.9.023

P453FC... Output flange
Flangia uscita

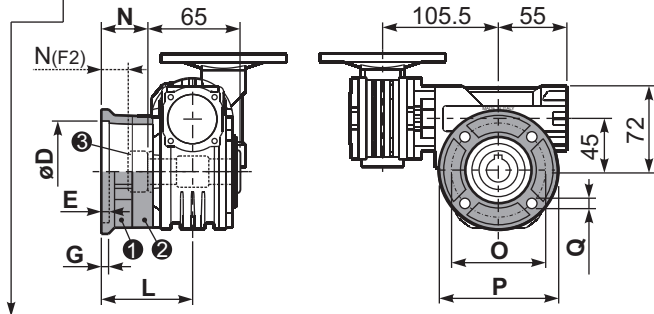

type B	øD	E	G	L	N	O	P	Q	kit code
FC	60 ^{+0.15} / _{-0.05}	9	9	60.5	28	87	110	8.5	① K045.9.010 ② -
FL	60 ^{+0.15} / _{-0.05}	9	9	90.5	58	87	110	8.5	① K045.9.010 ② K045.0.200

type S	øD	E	G	L	N	O	P	Q	kit code
F1	95 ^{+0.20} / _{-0.15}	4	11	73.5	41	115	140	9	① KS045.9.013 ② -
F2	60 ^{+0.15} / _{-0.05}	9	9	60.5	19	87	110	8.5	① KS045.9.010 ② S045.0.204
F3	80 ^{+0.030} / ₀	3	8	51.5	19	100	120	9	① KS045.9.014 ② -

P453BR... Reaction arm
Braccio di reazione

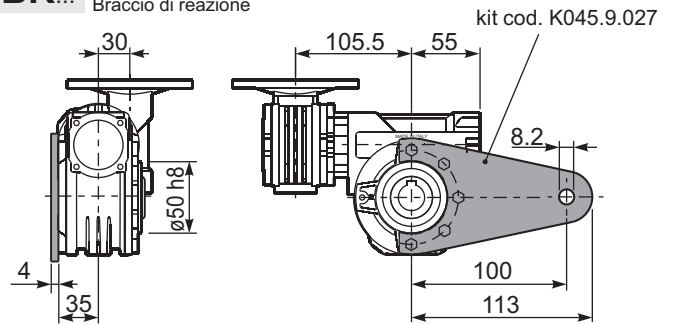

P453....S... Single Shaft
Albero lento semplice

P453....D... Double Shaft
Albero lento bisp.

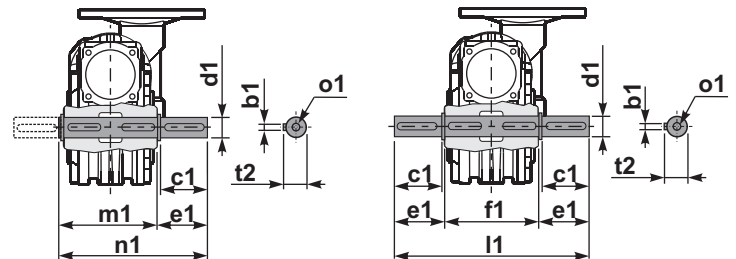

- ① kit cod. K045.5.028 type B
kit cod. KS045.5.030 type S
- ② kit cod. K045.5.029 type B
kit cod. KS045.5.031 type S

R453FB... Input shaft
Albero in entrata

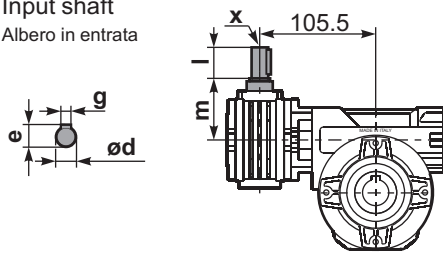

	ød	e	g	l	m	x	kit code
type B	9 h6	10.2	3	20	58	-	① K030.5.006 PAM63 ② -
type S	-	-	-	-	-	-	① - ② -

	b1	c1	d1	e1	f1	l1	m1	n1	t2	o1
type B	6	32	18 ^{-0.005} / _{-0.020}	43	65	151	70	113	20.5	M6x18
type S	6	40	19 ^{-0.005} / _{-0.020}	58.5	65	182	70	128.5	21.5	M8x20

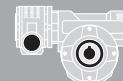

QUICK SELECTION / Selezione veloce

input speed (n_1) = 1400 min⁻¹

Output Speed n_2 [min ⁻¹]	Ratio i	Motor power P_{1M} [kW]	Output torque M_{2M} [Nm]	Service factor f.s.	Nominal power P_{1R} [kW]	Nominal torque M_{2R} [Nm]	Available B5 motor flanges		Available B14 motor flanges		Dynamic efficiency RD	Tooth Module Mn [mm]	Ratios code
							A	B	O	P			
5.6	252	0.12	97	1.0	0.12	95	B		B-C		47	2.1	01
3.9	360	0.12	124	0.8	0.09	95	B		B-C		42	2.1	02
2.6	540	0.12*	95	<0.8	0.07	95	B		B-C		39	2.1	03
1.9	720	0.12*	95	<0.8	0.05	95	B		B-C		36	2.1	04
1.6	860	0.12*	95	<0.8	0.05	95	B		B-C		32	1.8	05
1.2	1200	0.12*	95	<0.8	0.04	95	B		B-C		27	1.3	06
1.0	1440	0.12*	95	<0.8	0.04	95	B		B-C		26	2.1	07
0.8	1720	0.12*	95	<0.8	0.03	95	B		B-C		25	1.8	08
0.6	2400	0.12*	90	<0.8	0.03	90	B		B-C		21	1.3	09

Motor Flanges Available
Flange Motore Disponibili

B) Supplied with Reduction Bushing
Fornito con Bussola di Riduzione

B) Available on Request without reduction bushing
Disponibile a Richiesta senza Bussola di Riduzione



C) Motor Flange Holes Position
Posizione Fori Flangia Motore

* Power higher than the maximum one which can be supported by the gearbox. Select according to the torque M_{2R}
Potenza superiore a quella massima sopportabile dal riduttore. Selezionare in base al momento torcente M_{2R}

EN Unit 503 is supplied with synthetic oil, providing "long life" lubrication. For mounting position V5-V6 please contact us. See table 1 for lubrication and recommended quantity. In table 2 please see possible radial loads and axial loads on the gearbox. For complete documentation please visit our web site.

I Il riduttore tipo 503 viene fornito lubrificato a vita con olio sintetico. Per posizioni V5-V6 contattare il ns. servizio tecnico. Vedi tab.1 per oli e quantità consigliati. In tab.2 sono presenti i carichi radiali e assiali applicabili al riduttore. Per la documentazione completa consulta il nostro sito.

D Für die Lebensdauerschmierung ist das Getriebe der Größe 503 mit synthetischem Öl befüllt. Bei Einbaulage V5 oder V6 bitten wir um Rücksprache. In Tabelle 1 ist die Schmiermenge und das empfohlene Schmiermittel angegeben. In Tabelle 2 sind die zulässigen Radial- und Axialbelastungen des Getriebes aufgeführt. Die komplette Dokumentation, Wartungs- und Inbetriebnahmeanleitungen finden Sie unter.

E El reductor tamaño 503 se suministra, lubricado de por vida con aceite sintético. Para las posiciones V5 y V6 contactar con nuestro servicio técnico. Ver tabla 1, para cantidades y aceites recomendados. En la tabla 2, se encuentran las cargas radiales y axiales admitidas por el reductor. Para documentación completa, consultar nuestra Web.

■ LUBRICATION 503 Oil **Quantity 0.14/0.03 Lt.**

AGIP	KLUBER	SHELL	MOBIL
Telium VSF 320	Syntheso D220 EP	Tivela Oil WB	Glygoyl 30 SHC 630

tab. 1

■ RADIAL AND AXIAL LOADS

Output shaft
Albero di uscita

n_2 [min ⁻¹]	FA [N]	FR [N]
25	480	2500
15	560	2800

Input shaft
albero in entrata

n_1 [min ⁻¹]	FA [N]	FR [N]
1400	20	100

*Strong axial loads in the DX direction are not allowed.
Non sono consentiti forti carichi assiali con direzione DX

tab. 2

■ SELECT THIS TYPE AND THIS SPECIFIC SIZE ON THE WEB PAGES TO GET COMPLETE TECHNICAL DATA.
Selezionare tipo e gandezza specifica nel sito web per la documentazione completa.

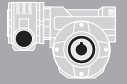

QUICK SELECTION / Selezione veloce							input speed (n ₁) = 1400 min ⁻¹						
Output Speed n ₂ [min ⁻¹]	Ratio i	Motor power P _{1M} [kW]	Output torque M _{2M} [Nm]	Service factor f.s.	Nominal power P _{1R} [kW]	Nominal torque M _{2R} [Nm]	Available B5 motor flanges		Available B14 motor flanges		Dynamic efficiency RD	Tooth Module Mn [mm]	Ratios code
							A	B	O	P			
5.6	252	0.18	142	1.4	0.25	200	B		B-C		46	2.7	01
3.9	360	0.18	181	1.1	0.20	200	B		B-C		41	2.7	02
2.6	540	0.12	164	1.2	0.15	200	B		B-C		37	2.7	03
1.9	720	0.12	200	1.0	0.12	200	B		B-C		34	2.7	04
1.3	1080	0.12	265	0.8	0.09	200	B		B-C		30	2.7	05
1.0	1440	0.12*	200	<0.8	0.08	200	B		B-C		27	2.7	06
0.5	2745	0.12*	200	<0.8	0.05	200	B		B-C		23	2.1	07

Motor Flanges Available Flange Motore Disponibili
 B) Supplied with Reduction Bushing Fornito con Bussola di Riduzione
 B) Available on Request without reduction bushing Disponibile a Richiesta senza Bussola di Riduzione
 C) Motor Flange Holes Position Posizione Fori Flangia Motore

* Power higher than the maximum one which can be supported by the gearbox. Select according to the torque M_{2R}
 Potenza superiore a quella massima sopportabile dal riduttore. Selezionare in base al momento torcente M_{2R}

EN Unit 633 is supplied with synthetic oil, providing "long life" lubrication. For mounting position V5-V6 please contact us. See table 1 for lubrication and recommended quantity. In table 2 please see possible radial loads and axial loads on the gearbox. For complete documentation please visit our web site.

I Il riduttore tipo 633 viene fornito lubrificato a vita con olio sintetico. Per posizioni V5-V6 contattare il ns. servizio tecnico. Vedi tab.1 per oli e quantità consigliati. In tab.2 sono presenti i carichi radiali e assiali applicabili al riduttore. Per la documentazione completa consulta il nostro sito.

D Für die Lebensdauerschmierung ist das Getriebe der Größe 633 mit synthetischem Öl befüllt. Bei Einbaulage V5 oder V6 bitten wir um Rücksprache. In Tabelle 1 ist die Schmiermenge und das empfohlene Schmiermittel angegeben. In Tabelle 2 sind die zulässigen Radial- und Axialbelastungen des Getriebes aufgeführt. Die komplette Dokumentation, Wartungs- und Inbetriebnahmeanleitungen finden Sie unter.

E El reductor tamaño 633 se suministra, lubricado de por vida con aceite sintético. Para las posiciones V5 y V6 contactar con nuestro servicio técnico. Ver tabla 1, para cantidades y aceites recomendados. En la tabla 2, se encuentran las cargas radiales y axiales admitidas por el reductor. Para documentación completa, consultar nuestra Web.

LUBRICATION 633 Oil 0.40 Lt. 0.03 Lt.

Quantity 0.40/0.06 Lt.

AGIP	KLUBER	SHELL	MOBIL
Telium VSF 320	Syntheso D220 EP	Tivela Oil WB	Glygoyl 30 SHC 630

tab. 1

RADIAL AND AXIAL LOADS

Output shaft
Albero di uscita

n ₂ [min ⁻¹]	FA [N]	FR [N]
25	700	3800
15	800	4000

Input shaft
albero in entrata

n ₁ [min ⁻¹]	FA [N]	FR [N]
1400	20	100

*Strong axial loads in the DX direction are not allowed.
 Non sono consentiti forti carichi assiali con direzione DX

tab. 2

SELECT THIS TYPE AND THIS SPECIFIC SIZE ON THE WEB PAGES TO GET COMPLETE TECHNICAL DATA.
 Selezionare tipo e gandezza specifica nel sito web per la documentazione completa.

3D dimensions on request

P633FB...

Basic wormbox
Riduttore base

Wormbox weight
peso riduttore **7.50 kg**

M. flanges	Kit code	øF	A
56B5	K030.4.041	120	61.5
63B5	K030.4.042	140	62.5
56B14	K030.4.046	80	61.5
63B14	K030.4.045	90	62.5

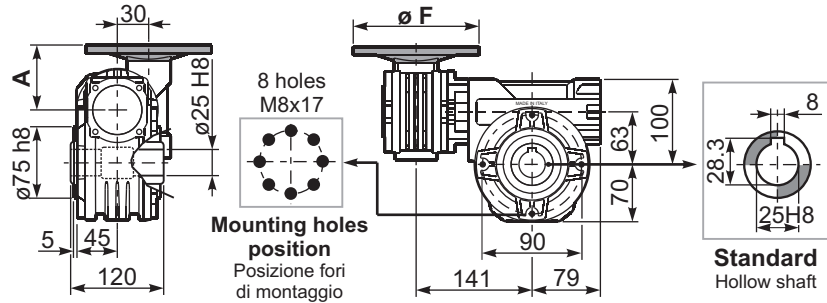

Standard
Hollow shaft

P633PA...

Feet
Piedini

P633PB...

Feet
Piedini

P633PV...

Feet
Piedini

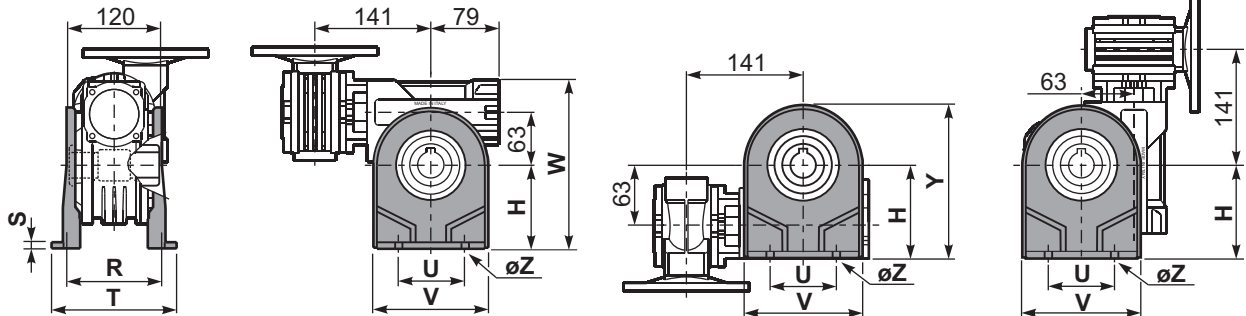

	H	R	S	T	U	V	Y	W	øZ	kit code
type B	100	111	4	144	95	133	170	200	ø10.5	K063.9.022
type S	-	-	-	-	-	-	-	-	-	-

P633FC...

Output flange
Flangia uscita

P633BR...

Reaction arm
Braccio di reazione

kit cod. K063.9.027

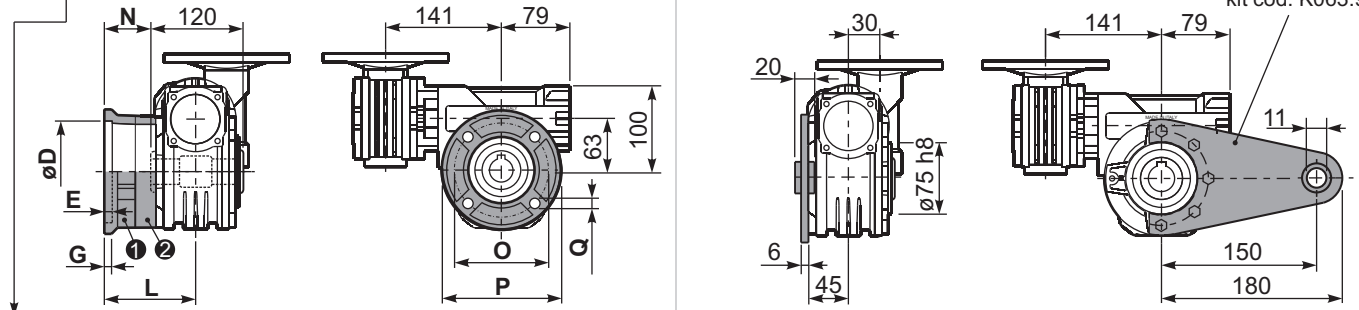

type B	øD	E	G	L	N	O	P	Q	kit code
FC	115 ^{+0.20} / _{+0.15}	7	13	86	26	150	175	11	① K063.9.010 ② -
FL	115 ^{+0.20} / _{+0.15}	7	13	116	56	150	175	11	① K063.9.010 ② K063.0.200

type S	øD	E	G	L	N	O	P	Q	kit code
F1	130 ^{+0.20} / _{+0.15}	7	13	102	42	165	200	13	① KS070.9.013 ② -
F2	115 ^{+0.20} / _{+0.15}	7	13	116	56	150	175	11	① KS063.9.013 ② -
F3	110 ^{+0.035} / ₀	5	11	82	22	130	160	10	① KS063.9.011 ② -

P633.....S...

Single Shaft
Albero lento semplice

P633.....D...

Double Shaft
Albero lento bisp.

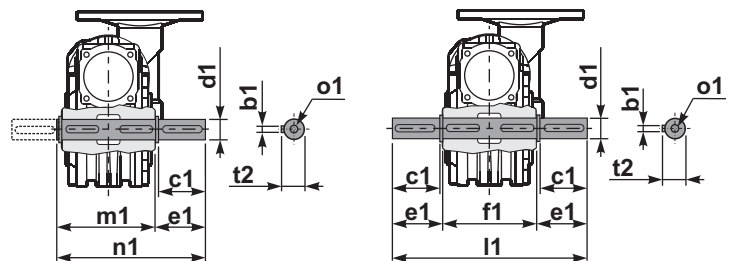

① kit cod. K063.5.028 type B

② kit cod. K063.5.029 type B

R633FB...

Input shaft
Albero in entrata

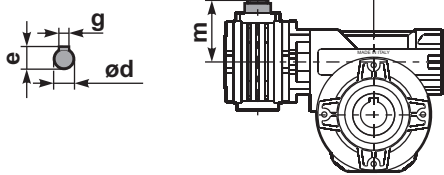

	ød	e	g	l	m	x	kit code
type B	9 h6	10.2	3	20	58	-	① K030.5.006 PAM63 ② -
type S	-	-	-	-	-	-	① - ② -

	b1	c1	d1	e1	f1	l1	m1	n1	t2	o1
type B	8	60	25 ^{-0.005} / _{-0.020}	63.2	120	246.4	126.8	190	28	M8x20
type S	-	-	-	-	-	-	-	-	-	-

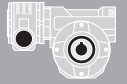

QUICK SELECTION / Selezione veloce

input speed (n_1) = 1400 min⁻¹

Output Speed n_2 [min ⁻¹]	Ratio i	Motor power P_{1M} [kW]	Output torque M_{2M} [Nm]	Service factor f.s.	Nominal power P_{1R} [kW]	Nominal torque M_{2R} [Nm]	Available B5 motor flanges		Available B14 motor flanges			Dynamic efficiency RD	Tooth Module M_n [mm]	Ratios code
							B	C	O	P	Q			
							63	71	56	63	71			
5.6	252	0.18	142	1.6	0.29	230	B		B-C	B-C		46	2.7	01
3.9	360	0.18	186	1.2	0.22	230	B		B-C	B-C		42	2.7	02
2.8	504	0.12	161	1.4	0.17	230	B		B-C	B-C		39	2.7	03
1.9	756	0.12	204	1.1	0.14	230	B		B-C	B-C		33	2.7	04
1.4	1008	0.12	256	0.9	0.11	230	B		B-C	B-C		31	2.7	05
1.1	1332	0.12*	230	<0.8	0.08	230	B		B-C	B-C		30	2.7	06
0.8	1656	0.12*	230	<0.8	0.07	230	B		B-C	B-C		28	2.7	07
0.6	2160	0.12*	230	<0.8	0.06	230	B		B-C	B-C		26	2.7	08
0.6	2520	0.12*	230	<0.8	0.05	230	B		B-C	B-C		25	2.7	09

Motor Flanges Available
Flange Motore Disponibili

B) Supplied with Reduction Bushing
Fornito con Bussola di Riduzione

B) Available on Request without reduction bushing
Disponibile a Richiesta senza Bussola di Riduzione

C) Motor Flange Holes Position
Posizione Fori Flangia Motore

* Power higher than the maximum one which can be supported by the gearbox. Select according to the torque M_{2R}
Potenza superiore a quella massima sopportabile dal riduttore. Selezionare in base al momento torcente M_{2R}

EN Unit 634 is supplied with synthetic oil, providing "long life" lubrication. For mounting position V5-V6 please contact us. See table 1 for lubrication and recommended quantity. In table 2 please see possible radial loads and axial loads on the gearbox. For complete documentation please visit our web site.

I Il riduttore tipo 634 viene fornito lubrificato a vita con olio sintetico. Per posizioni V5-V6 contattare il ns. servizio tecnico. Vedi tab.1 per oli e quantità consigliati. In tab.2 sono presenti i carichi radiali e assiali applicabili al riduttore. Per la documentazione completa consulta il nostro sito.

D Für die Lebensdauerschmierung ist das Getriebe der Größe 634 mit synthetischem Öl befüllt. Bei Einbaulage V5 oder V6 bitten wir um Rücksprache. In Tabelle 1 ist die Schmiermenge und das empfohlene Schmiermittel angegeben. In Tabelle 2 sind die zulässigen Radial- und Axialbelastungen des Getriebes aufgeführt. Die komplette Dokumentation, Wartungs- und Inbetriebnahmeanleitungen finden Sie unter.

E El reductor tamaño 634 se suministra, lubricado de por vida con aceite sintético. Para las posiciones V5 y V6 contactar con nuestro servicio técnico. Ver tabla 1, para cantidades y aceites recomendados. En la tabla 2, se encuentran las cargas radiales y axiales admitidas por el reductor. Para documentación completa, consultar nuestra Web.

LUBRICATION 634 Oil 0.40 Lt. 0.09 Lt.

Quantity 0.40/0.09 Lt.

AGIP	KLUBER	SHELL	MOBIL
Telium VSF 320	Syntheso D220 EP	Tivela Oil WB	Glygoyl 30 SHC 630

tab. 1

RADIAL AND AXIAL LOADS

Output shaft
Albero di uscita

n_2 [min ⁻¹]	FA [N]	FR [N]
25	700	3800
15	800	4000

Input shaft
albero in entrata

n_1 [min ⁻¹]	FA [N]	FR [N]
1400	42	210

***Strong axial loads in the DX direction are not allowed.**
Non sono consentiti forti carichi assiali con direzione DX

tab. 2

SELECT THIS TYPE AND THIS SPECIFIC SIZE ON THE WEB PAGES TO GET COMPLETE TECHNICAL DATA.
Selezionare tipo e gandezza specifica nel sito web per la documentazione completa.

3D dimensions on request

P634FB...

Basic wormbox
Riduttore base

Wormbox weight
peso riduttore **8.90 kg**

M. flanges	Kit code	øF	A
63B5	K050.4.041	138	72
71B5	K050.4.042	160	70
56B14	KC40.4.049	80	71.5
63B14	K050.4.047	90	74
71B14	K050.4.045	105	71.5

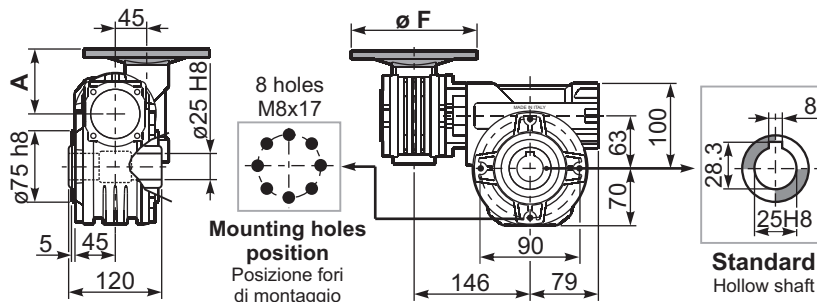

P634PA...

Feet
Piedini

P634PB...

Feet
Piedini

P634PV...

Feet
Piedini

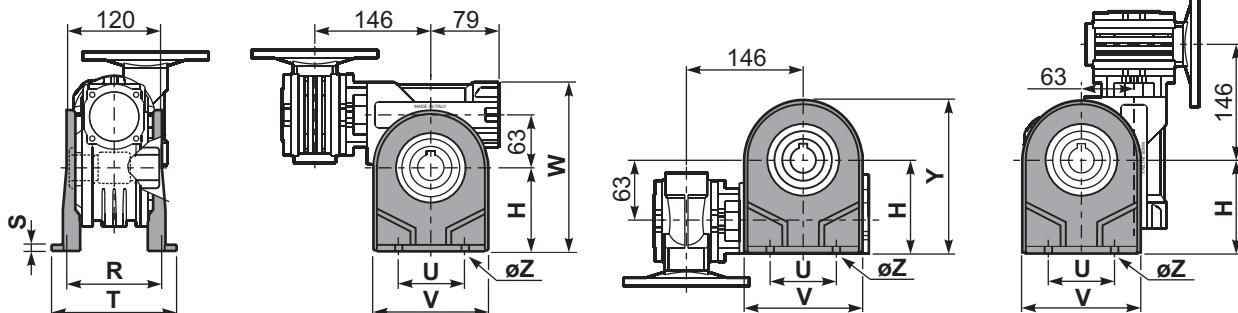

	H	R	S	T	U	V	Y	W	øZ	kit code
type B	100	111	4	144	95	133	170	200	ø10.5	K063.9.022
type S	-	-	-	-	-	-	-	-	-	-

P634FC...

Output flange
Flangia uscita

P634BR...

Reaction arm
Braccio di reazione

kit cod. K063.9.027

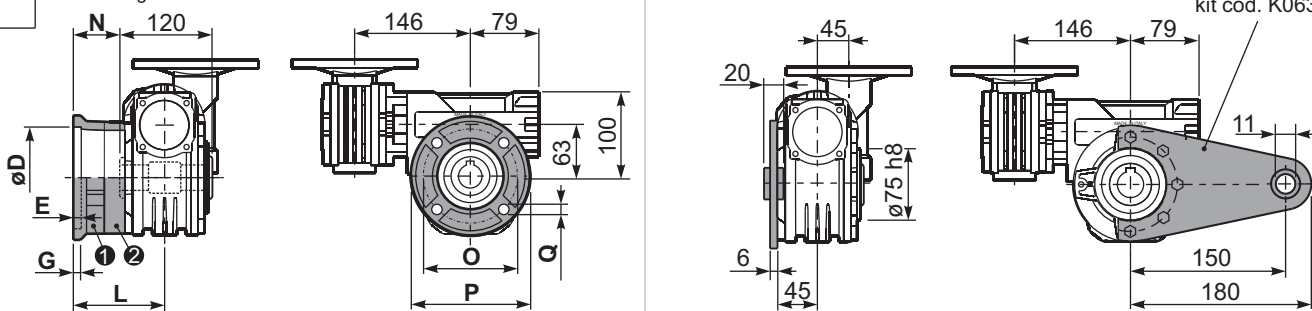

type B	øD	E	G	L	N	O	P	Q	kit code
FC	115 ^{+0.20} / _{+0.15}	7	13	86	26	150	175	11	① K063.9.010 ② -
FL	115 ^{+0.20} / _{+0.15}	7	13	116	56	150	175	11	① K063.9.010 ② K063.0.200
type S	øD	E	G	L	N	O	P	Q	kit code
F1	130 ^{+0.20} / _{+0.15}	7	13	102	42	165	200	13	① KS070.9.013 ② -
F2	115 ^{+0.20} / _{+0.15}	7	13	116	56	150	175	11	① KS063.9.013 ② -
F3	110 ^{+0.035} / ₀	5	11	82	22	130	160	10	① KS063.9.011 ② -

P634.....S...

Single Shaft
Albero lento semplice

P634.....D...

Double Shaft
Albero lento bisp.

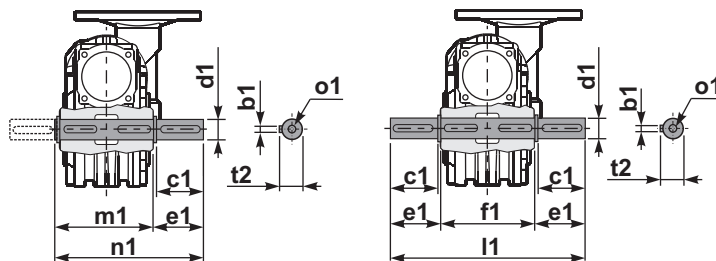

① kit cod. K063.5.028 type B

② kit cod. K063.5.029 type B

R634FB...

Input shaft
Albero in entrata

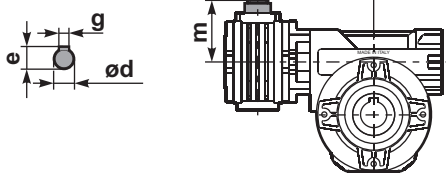

	ød	e	g	l	m	x	kit code
type B	11 h6	12.5	4	30	68	-	① ② K045.5.006 PAM71
type S	-	-	-	-	-	-	① ② -

	b1	c1	d1	e1	f1	l1	m1	n1	t2	o1
type B	8	60	25 ^{-0.005} / _{-0.020}	63.2	120	246.4	126.8	190	28	M8x20
type S	-	-	-	-	-	-	-	-	-	-

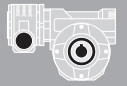

QUICK SELECTION / Selezione veloce							input speed (n ₁) = 1400 min ⁻¹						
Output Speed n ₂ [min ⁻¹]	Ratio i	Motor power P _{1M} [kW]	Output torque M _{2M} [Nm]	Service factor f.s.	Nominal power P _{1R} [kW]	Nominal torque M _{2R} [Nm]	Available B5 motor flanges		Available B14 motor flanges		Dynamic efficiency RD	Tooth Module Mn [mm]	Ratios code
							A	B	O	P			
5.6	252	0.18	142	1.8	0.32	252	B		B-C		46	2.7	01
3.9	360	0.18	181	1.4	0.25	252	B		B-C		41	2.7	02
2.6	540	0.12	164	1.5	0.18	252	B		B-C		37	2.7	03
1.9	720	0.12	200	1.3	0.15	252	B		B-C		34	2.7	04
1.3	1080	0.12	265	1.0	0.11	252	B		B-C		30	2.7	05
1.0	1440	0.12	318	0.8	0.10	252	B		B-C		27	2.7	06
0.5	2745	0.12*	210	<0.8	0.05	210	B		B-C		23	2.1	07

A) Motor Flanges Available
Flange Motore Disponibili

B) Supplied with Reduction Bushing
Fornito con Bussola di Riduzione

B) Available on Request without reduction bushing
Disponibile a Richiesta senza Bussola di Riduzione

C) Motor Flange Holes Position
Posizione Fori Flangia Motore

* Power higher than the maximum one which can be supported by the gearbox. Select according to the torque M_{2R}
Potenza superiore a quella massima sopportabile dal riduttore. Selezionare in base al momento torcente M_{2R}

EN Unit 6A3 is supplied with synthetic oil, providing "long life" lubrication. For mounting position V5-V6 please contact us. See table 1 for lubrication and recommended quantity. In table 2 please see possible radial loads and axial loads on the gearbox. For complete documentation please visit our web site.

I Il riduttore tipo 6A3 viene fornito lubrificato a vita con olio sintetico. Per posizioni V5-V6 contattare il ns. servizio tecnico. Vedi tab.1 per oli e quantità consigliati. In tab.2 sono presenti i carichi radiali e assiali applicabili al riduttore. Per la documentazione completa consulta il nostro sito.

D Für die Lebensdauerschmierung ist das Getriebe der Größe 6A3 mit synthetischem Öl befüllt. Bei Einbaulage V5 oder V6 bitten wir um Rücksprache. In Tabelle 1 ist die Schmiermenge und das empfohlene Schmiermittel angegeben. In Tabelle 2 sind die zulässigen Radial- und Axialbelastungen des Getriebes aufgeführt. Die komplette Dokumentation, Wartungs- und Inbetriebnahmeanleitungen finden Sie unter.

E El reductor tamaño 6A3 se suministra, lubricado de por vida con aceite sintético. Para las posiciones V5 y V6 contactar con nuestro servicio técnico. Ver tabla 1, para cantidades y aceites recomendados. En la tabla 2, se encuentran las cargas radiales y axiales admitidas por el reductor. Para documentación completa, consultar nuestra Web.

LUBRICATION 6A3 Oil Quantity 0.40/0.06 Lt.			
AGIP	KLUBER	SHELL	MOBIL
Telium VSF 320	Syntheso D220 EP	Tivela Oil WB	Glygoyl 30 SHC 630

tab. 1

RADIAL AND AXIAL LOADS			
Output shaft Albero di uscita			
	n ₂ [min ⁻¹]	FA [N]	FR [N]
	25	700	3800
	15	800	4000
Input shaft albero in entrata			
	n ₁ [min ⁻¹]	FA [N]	FR [N]
	1400	20	100
	*Strong axial loads in the DX direction are not allowed. Non sono consentiti forti carichi assiali con direzione DX		

tab. 2

SELECT THIS TYPE AND THIS SPECIFIC SIZE ON THE WEB PAGES TO GET COMPLETE TECHNICAL DATA.
Selezionare tipo e gandezza specifica nel sito web per la documentazione completa.

3D dimensions on request

P6A3FB... Basic wormbox
Riduttore base

M. flanges	Kit code	øF	A
56B5	K030.4.041	120	61.5
63B5	K030.4.042	140	62.5
56B14	K030.4.046	80	61.5
63B14	K030.4.045	90	62.5

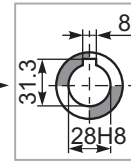
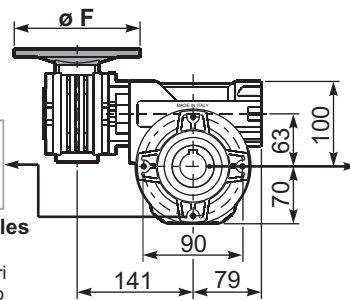
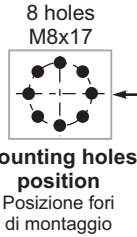
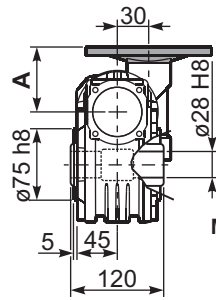

Standard
Hollow shaft

Wormbox weight
peso riduttore **8.90 kg**

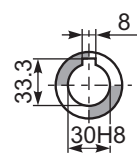

On request
A richiesta

P6A3PA... Feet
Piedini

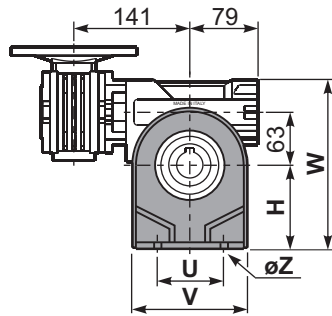
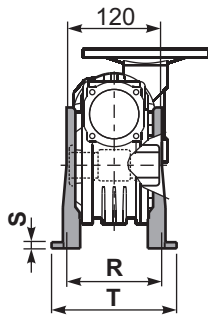

P6A3PB... Feet
Piedini

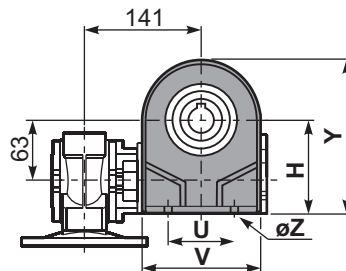

P6A3PV... Feet
Piedini

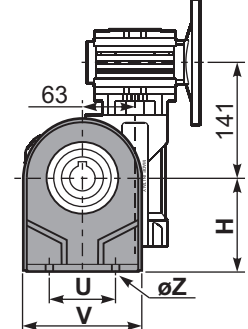

	H	R	S	T	U	V	Y	W	øZ	kit code
type B	115	115	12	142	120	156	185	215	ø11	K070.9.022
type S	-	-	-	-	-	-	-	-	-	-

P6A3FC... Output flange
Flangia uscita

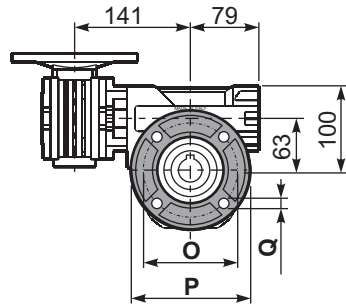
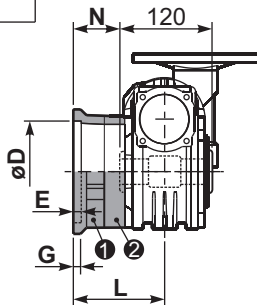

type B	øD	E	G	L	N	O	P	Q	kit code
FC	130 ^{+0.20} / _{+0.15}	7	13	85	25	165	200	13	① K070.9.010 ② -
FL	130 ^{+0.20} / _{+0.15}	7	13	111	51	165	200	13	① K070.9.010 ② K070.0.200
type S	øD	E	G	L	N	O	P	Q	kit code
F1	130 ^{+0.20} / _{+0.15}	7	13	111	51	165	200	13	① KS070.9.014 ② -
F2	115 ^{+0.20} / _{+0.15}	7	13	116	56	150	175	11	① KS063.9.013 ② -
F3	110 ^{+0.035} / ₀	5	13.5	84.5	24.5	130	160	11	① KS070.9.011 ② -

P6A3BR... Reaction arm
Braccio di reazione

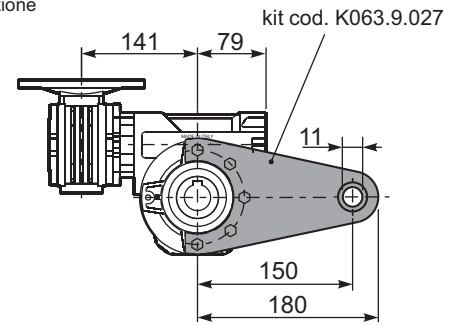
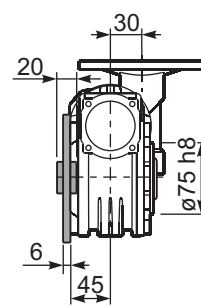

P6A3....S... Single Shaft
Albero lento semplice

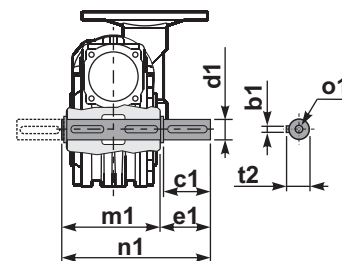

P6A3....D... Double Shaft
Albero lento bisp.

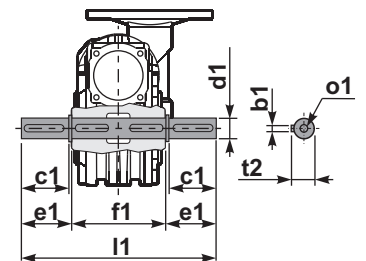

① kit cod. K070.5.028 type B

② kit cod. K070.5.029 type B

R6A3FB... Input shaft
Albero in entrata

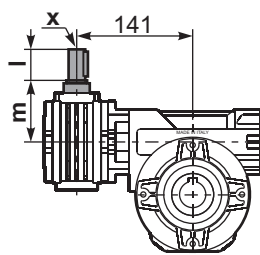
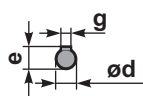

	ød	e	g	l	m	x	kit code
type B	9 h6	10.2	3	20	58	-	① K030.5.006 PAM63 ② -
type S	-	-	-	-	-	-	① - ② -

	b1	c1	d1	e1	f1	l1	m1	n1	t2	o1
type B	8	60	28 ^{-0.005} / _{-0.020}	63.5	120	247	127.5	191	31	M8x20
type S	-	-	-	-	-	-	-	-	-	-

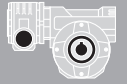

QUICK SELECTION / Selezione veloce

input speed (n_1) = 1400 min⁻¹

Output Speed n_2 [min ⁻¹]	Ratio i	Motor power P_{1M} [kW]	Output torque M_{2M} [Nm]	Service factor f.s.	Nominal power P_{1R} [kW]	Nominal torque M_{2R} [Nm]	Available B5 motor flanges		Available B14 motor flanges			Dynamic efficiency RD	Tooth Module M_n [mm]	Ratios code
							B	C	O	P	Q			
							63	71	56	63	71			
5.6	252	0.18	142	1.9	0.33	264	B		B-C	B-C		46	2.7	01
3.9	360	0.18	186	1.4	0.26	264	B		B-C	B-C		42	2.7	02
2.8	504	0.18	241	1.1	0.20	264	B		B-C	B-C		39	2.7	03
1.9	756	0.12	204	1.3	0.16	264	B		B-C	B-C		33	2.7	04
1.4	1008	0.12	256	1.0	0.12	264	B		B-C	B-C		31	2.7	05
1.1	1332	0.12	327	0.8	0.10	264	B		B-C	B-C		30	2.7	06
0.8	1656	0.12*	264	<0.8	0.08	264	B		B-C	B-C		28	2.7	07
0.6	2160	0.12*	264	<0.8	0.07	264	B		B-C	B-C		26	2.7	08
0.6	2520	0.12*	264	<0.8	0.06	264	B		B-C	B-C		25	2.7	09

Motor Flanges Available
Flange Motore Disponibili

B) Supplied with Reduction Bushing
Fornito con Bussola di Riduzione

B) Available on Request without reduction bushing
Disponibile a Richiesta senza Bussola di Riduzione

C) Motor Flange Holes Position
Posizione Fori Flangia Motore

* Power higher than the maximum one which can be supported by the gearbox. Select according to the torque M_{2R}
Potenza superiore a quella massima sopportabile dal riduttore. Selezionare in base al momento torcente M_{2R}

EN Unit 6A4 is supplied with synthetic oil, providing "long life" lubrication. For mounting position V5-V6 please contact us. See table 1 for lubrication and recommended quantity. In table 2 please see possible radial loads and axial loads on the gearbox. For complete documentation please visit our web site.

I Il riduttore tipo 6A4 viene fornito lubrificato a vita con olio sintetico. Per posizioni V5-V6 contattare il ns. servizio tecnico. Vedi tab.1 per oli e quantità consigliati. In tab.2 sono presenti i carichi radiali e assiali applicabili al riduttore. Per la documentazione completa consulta il nostro sito.

D Für die Lebensdauerschmierung ist das Getriebe der Größe 6A4 mit synthetischem Öl befüllt. Bei Einbaulage V5 oder V6 bitten wir um Rücksprache. In Tabelle 1 ist die Schmiermenge und das empfohlene Schmiermittel angegeben. In Tabelle 2 sind die zulässigen Radial- und Axialbelastungen des Getriebes aufgeführt. Die komplette Dokumentation, Wartungs- und Inbetriebnahmeanleitungen finden Sie unter.

E El reductor tamaño 6A4 se suministra, lubricado de por vida con aceite sintético. Para las posiciones V5 y V6 contactar con nuestro servicio técnico. Ver tabla 1, para cantidades y aceites recomendados. En la tabla 2, se encuentran las cargas radiales y axiales admitidas por el reductor. Para documentación completa, consultar nuestra Web.

LUBRICATION 6A4 Oil 0.40 Lt. 0.09 Lt.

Quantity 0.40/0.06 Lt.

AGIP	KLUBER	SHELL	MOBIL
Telium VSF 320	Syntheso D220 EP	Tivela Oil WB	Glygoyl 30 SHC 630

tab. 1

RADIAL AND AXIAL LOADS

Output shaft
Albero di uscita

n_2 [min ⁻¹]	FA [N]	FR [N]
25	700	3800
15	800	4000

Input shaft
albero in entrata

n_1 [min ⁻¹]	FA [N]	FR [N]
1400	42	210

*Strong axial loads in the DX direction are not allowed.
Non sono consentiti forti carichi assiali con direzione DX

tab. 2

SELECT THIS TYPE AND THIS SPECIFIC SIZE ON THE WEB PAGES TO GET COMPLETE TECHNICAL DATA.
Selezionare tipo e gandezza specifica nel sito web per la documentazione completa.

3D dimensions on request

P6A4FB... Basic wormbox
Riduttore base

M. flanges	Kit code	øF	A
63B5	K050.4.041	138	72
71B5	K050.4.042	160	70
56B14	KC40.4.049	80	71.5
63B14	K050.4.047	90	74
71B14	K050.4.045	105	71.5

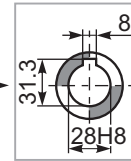
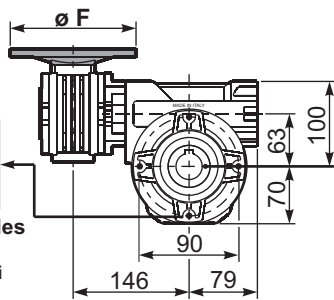
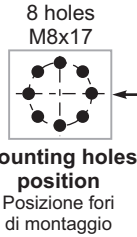
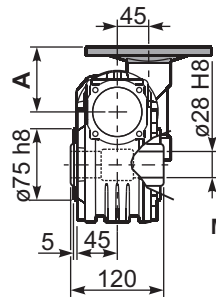

Standard
Hollow shaft

Wormbox weight
peso riduttore **8.90 kg**

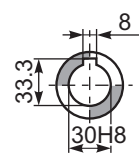

On request
A richiesta

P6A4PA... Feet
Piedini

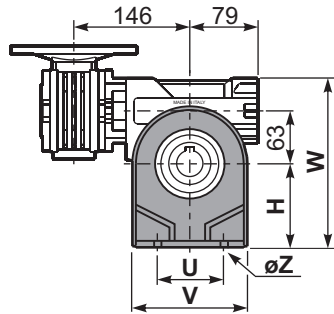
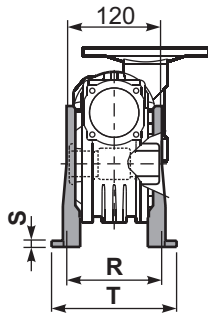

P6A4PB... Feet
Piedini

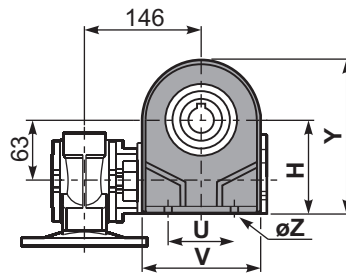

P6A4PV... Feet
Piedini

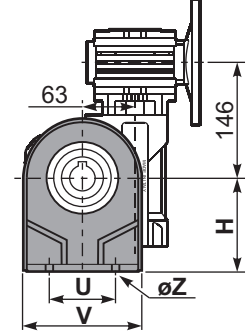

	H	R	S	T	U	V	Y	W	øZ	kit code
type B	115	115	12	142	120	156	185	215	ø11	K070.9.022
type S	-	-	-	-	-	-	-	-	-	-

P6A4FC... Output flange
Flangia uscita

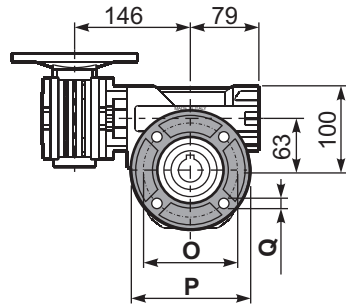
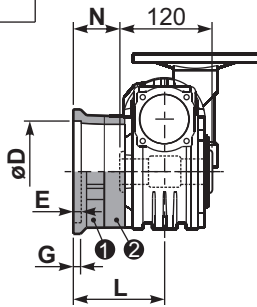

type B	øD	E	G	L	N	O	P	Q	kit code
FC	130 ^{+0.20} / _{+0.15}	7	13	85	25	165	200	13	1 K070.9.010 2 -
FL	130 ^{+0.20} / _{+0.15}	7	13	111	51	165	200	13	1 K070.9.010 2 K070.0.200
type S	øD	E	G	L	N	O	P	Q	kit code
F1	130 ^{+0.20} / _{+0.15}	7	13	111	51	165	200	13	1 KS070.9.014 2 -
F2	115 ^{+0.20} / _{+0.15}	7	13	116	56	150	175	11	1 KS063.9.013 2 -
F3	110 ^{+0.035} / ₀	5	13.5	84.5	24.5	130	160	11	1 KS070.9.011 2 -

P6A4BR... Reaction arm
Braccio di reazione

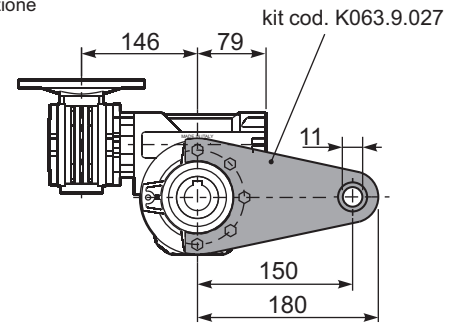
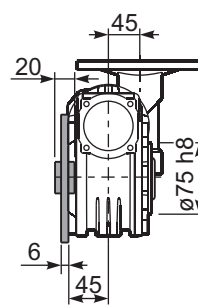

P6A4....S... Single Shaft
Albero lento semplice

P6A4....D... Double Shaft
Albero lento bisp.

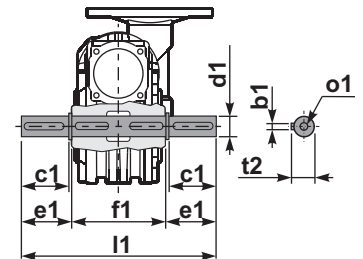
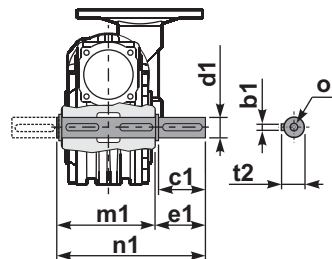

1 kit cod. K070.5.028 type B

2 kit cod. K070.5.029 type B

R6A4FB... Input shaft
Albero in entrata

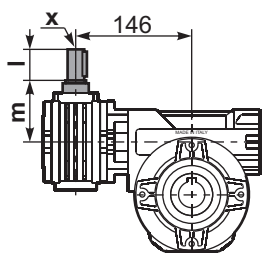
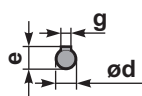

	ød	e	g	l	m	x	kit code
type B	11 h6	12.5	4	30	68	-	1 2 K045.5.006 PAM71
type S	-	-	-	-	-	-	1 2 -

	b1	c1	d1	e1	f1	l1	m1	n1	t2	o1
type B	8	60	28 ^{-0.005} / _{-0.020}	63.5	120	247	127.5	191	31	M8x20
type S	-	-	-	-	-	-	-	-	-	-

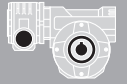

QUICK SELECTION / Selezione veloce

input speed (n_1) = 1400 min⁻¹

Output Speed n_2 [min ⁻¹]	Ratio i	Motor power P_{1M} [kW]	Output torque M_{2M} [Nm]	Service factor f.s.	Nominal power P_{1R} [kW]	Nominal torque M_{2R} [Nm]	Available B5 motor flanges		Available B14 motor flanges			Dynamic efficiency RD	Tooth Module M_n [mm]	Ratios code
							B	C	O	P	Q			
							63	71	56	63	71			
10	140	0.37	205	1.6	0.58	320	B		B-C	B-C		58	4.5	01
7.1	196	0.37	257	1.2	0.46	320	B		B-C	B-C		52	4.7	02
5.0	280	0.37	332	1.4	0.50	450	B		B-C	B-C		47	4.7	03
3.6	392	0.37	435	1.0	0.38	450	B		B-C	B-C		44	4.7	04
2.4	588	0.25	371	1.2	0.30	450	B		B-C	B-C		37	4.7	05
1.8	784	0.25	455	1.0	0.25	450	B		B-C	B-C		34	4.7	06
1.4	1036	0.18	420	1.1	0.19	450	B		B-C	B-C		33	4.7	07
1.1	1288	0.18	474	0.9	0.17	450	B		B-C	B-C		30	4.7	08
0.7	1960	0.12	449	1.0	0.12	450	B		B-C	B-C		28	4.7	09
0.5	2856	0.12	584	0.8	0.09	450	B		B-C	B-C		25	4.7	10

A Motor Flanges Available
Flange Motore Disponibili

B Supplied with Reduction Bushing
Fornito con Bussola di Riduzione

B Available on Request without reduction bushing
Disponibile a Richiesta senza Bussola di Riduzione

C Motor Flange Holes Position
Posizione Fori Flangia Motore

EN Unit 854 is supplied with synthetic oil, providing "long life" lubrication. For mounting position V5-V6 please contact us. See table 1 for lubrication and recommended quantity. In table 2 please see possible radial loads and axial loads on the gearbox. For complete documentation please visit our web site.

I Il riduttore tipo 854 viene fornito lubrificato a vita con olio sintetico. Per posizioni V5-V6 contattare il ns. servizio tecnico. Vedi tab.1 per oli e quantità consigliati. In tab.2 sono presenti i carichi radiali e assiali applicabili al riduttore. Per la documentazione completa consulta il nostro sito.

D Für die Lebensdauerschmierung ist das Getriebe der Größe 854 mit synthetischem Öl befüllt. Bei Einbaulage V5 oder V6 bitten wir um Rücksprache. In Tabelle 1 ist die Schmiermenge und das empfohlene Schmiermittel angegeben. In Tabelle 2 sind die zulässigen Radial - und Axialbelastungen des Getriebes aufgeführt. Die komplette Dokumentation, Wartungs - und Inbetriebnahmeanleitungen finden Sie unter.

E El reductor tamaño 854 se suministra, lubricado de por vida con aceite sintético. Para las posiciones V5 y V6 contactar con nuestro servicio técnico. Ver tabla 1, para cantidades y aceites recomendados. En la tabla 2, se encuentran las cargas radiales y axiales admitidas por el reductor. Para documentación completa, consultar nuestra Web.

LUBRICATION 854 Oil 1.2 Lt. 0.09 Lt.
Quantity 1.2/0.09 Lt.

AGIP	KLUBER	SHELL	MOBIL
Telium VSF 320	Syntheso D220 EP	Tivela Oil WB	Glygoyl 30 SHC 630

tab. 1

RADIAL AND AXIAL LOADS

Output shaft
Albero di uscita

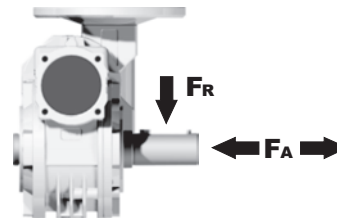

n_2 [min ⁻¹]	FA [N]	FR [N]
25	1000	5000
15	1160	5800

Input shaft
albero in entrata

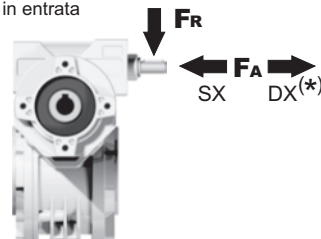

n_1 [min ⁻¹]	FA [N]	FR [N]
1400	42	210

*Strong axial loads in the DX direction are not allowed.
Non sono consentiti forti carichi assiali con direzione DX

tab. 2

SELECT THIS TYPE AND THIS SPECIFIC SIZE ON THE WEB PAGES TO GET COMPLETE TECHNICAL DATA.
Selezionare tipo e gandezza specifica nel sito web per la documentazione completa.

3D dimensions on request

P854FB... Basic wormbox
Riduttore base

M. flanges	Kit code	øF	A
63B5	K050.4.041	138	72
71B5	K050.4.042	160	70
56B14	KC40.4.049	80	71.5
63B14	K050.4.047	90	74
71B14	K050.4.045	105	71.5

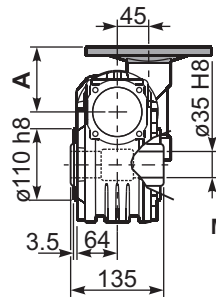

4 holes
M10x18
Mounting holes
position
Posizione fori
di montaggio

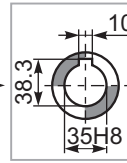
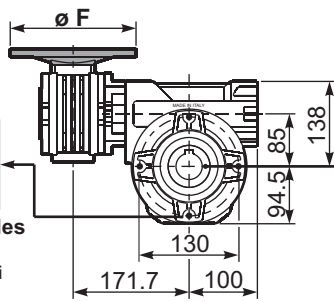

Standard
Hollow shaft

Wormbox
weight
peso riduttore **19.50 kg**

P854PA... Feet
Piedini

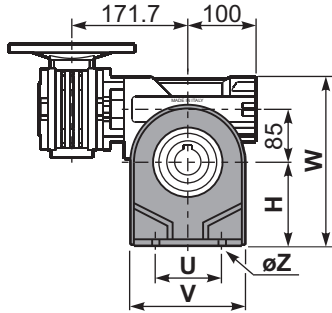
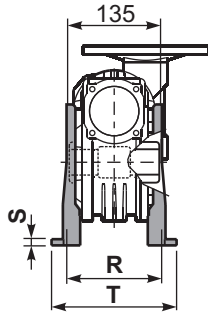

P854PB... Feet
Piedini

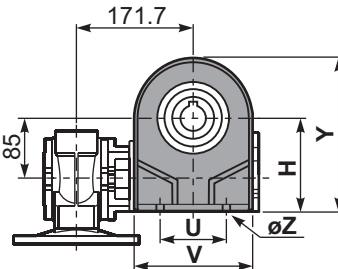

P854PV... Feet
Piedini

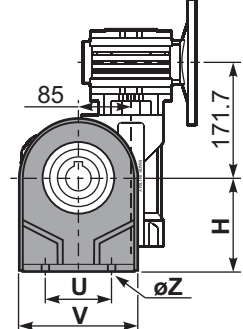

	H	R	S	T	U	V	Y	W	øZ	kit code
type B	142	145	5	182	140	180	236.5	280	ø10.5	K085.9.022
type S	-	-	-	-	-	-	-	-	-	-

P854FC... Output flange
Flangia uscita

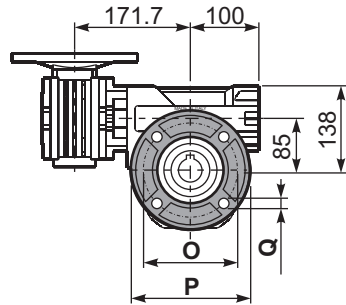
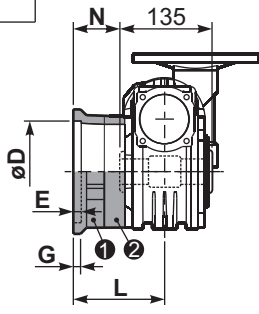

type B	øD	E	G	L	N	O	P	Q	kit code
FC	152 ^{+0.06} / _{+0.00}	5	16	108	40.5	176	205	13	1 K085.9.010 2 -
FL	152 ^{+0.06} / _{+0.00}	5	16	148.5	81	176	205	13	1 K085.9.010 2 K085.0.201
type S	øD	E	G	L	N	O	P	Q	kit code
F1	130 ^{+0.040} / ₀	5	13	117.5	50	165	200	11.5	1 KS085.9.012 2 -
F2	152 ^{+0.06} / ₀	5	15	147.5	80	180	205	12.5	1 KS085.9.013 2 -
F4	130 ^{+0.040} / ₀	5	13	106.5	39	165	200	13	1 KS085.9.015 2 -

P854BR... Reaction arm
Braccio di reazione

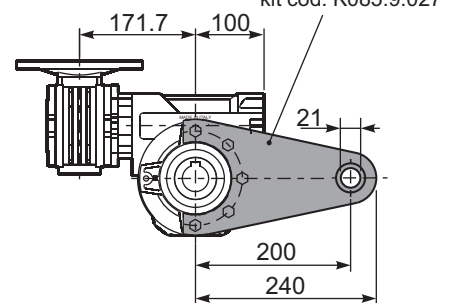
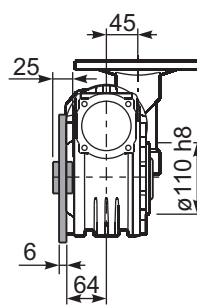

P854.....S... Single Shaft
Albero lento semplice

P854.....D... Double Shaft
Albero lento bisp.

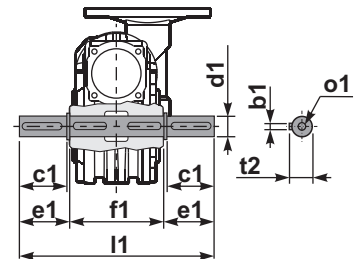
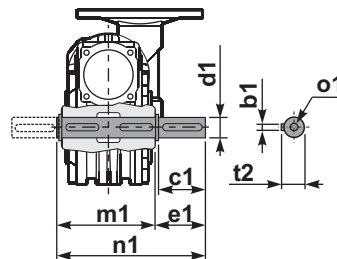

1 kit cod. K085.5.028 type B

2 kit cod. K085.5.029 type B

R854FB... Input shaft
Albero in entrata

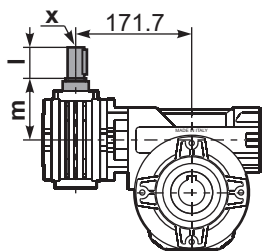
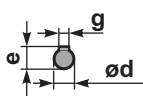

	ød	e	g	l	m	x	kit code
type B	11 h6	12.5	4	30	68	-	1 K045.5.006 PAM71 2 -
type S	-	-	-	-	-	-	1 - 2 -

	b1	c1	d1	e1	f1	l1	m1	n1	t2	o1
type B	10	60	35 ^{-0.005} / _{-0.020}	73.5	135	282	141	214.5	38	M10x23
type S	-	-	-	-	-	-	-	-	-	-

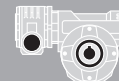

QUICK SELECTION / Selezione veloce

input speed (n_1) = 1400 min⁻¹

Output Speed n_2 [min ⁻¹]	Ratio i	Motor power P_{1M} [kW]	Output torque M_{2M} [Nm]	Service factor f.s.	Nominal power P_{1R} [kW]	Nominal torque M_{2R} [Nm]	Available B5 motor flanges			Available B14 motor flanges				Dynamic efficiency RD	Tooth Module M_n [mm]	Ratios code
							B	C	D	O	P	Q	R			
							63	71	80	56	63	71	80			
6.7	210	0.75	591	1.3	0.95	750	B	B		B-C	B-C	B		55	5.6	01
4.7	300	0.75	752	1.1	0.85	850	B	B		B-C	B-C	B		49	5.6	02
3.3	420	0.55	741	1.1	0.63	850	B	B		B-C	B-C	B		47	5.6	03
2.6	540	0.55	851	1.0	0.55	850	B	B		B-C	B-C	B		42	5.6	04
1.8	780	0.37	748	1.1	0.42	850	B	B		B-C	B-C	B		38	5.6	05
1.3	1080	0.25	681	1.2	0.31	850	B			B-C	B-C			37	5.6	06
1.1	1290	0.25	770	1.1	0.28	850	B			B-C	B-C			35	5.6	07
0.8	1800	0.25	921	0.9	0.23	850	B			B-C	B-C			30	5.6	08
0.7	2040	0.18	751	1.1	0.20	850	B			B-C	B-C			30	5.6	09
0.6	2400	0.18	825	1.0	0.19	850	B			B-C	B-C			28	5.6	10
0.5	3000	0.12	638	1.3	0.16	850	B			B-C	B-C			26	5.6	11

Motor Flanges Available
Flange Motore Disponibili

B) Supplied with Reduction Bushing
Fornito con Bussola di Riduzione

B) Available on Request without reduction bushing
Disponibile a Richiesta senza Bussola di Riduzione



C) Motor Flange Holes Position
Posizione Fori Flangia Motore

EN Unit 115 is supplied without lubricant and equipped with a breather, level and drain plugs. User can add mineral oil keeping existing plugs. Should the user wish to fill it with synthetic oil, it is recommended to replace the existing plugs with a type that are closed. Gearbox 050 is supplied lubricated for life. See tab.1 for oils and recommended quantity. In tab.2 there are radial loads and axial loads applicable to the gearbox. For the complete documentation please visit our web site:

B3	B6	B7	B8	V5	V6
2.0/0.14 LT	1.5/0.14 LT	1.5/0.14 LT	2.0/0.14 LT	2.0/0.14 LT	2.0/0.14 LT
AGIP	BP	SHELL	KLUBER	MOBIL	
Telium VSF 320	Energol SGXP220	Tivela Oil WB	Syntheso D220 EF	Glygoyl 30	

tab. 1

I Il riduttore tipo 115 è fornito privo di lubrificazione con tappi di sfiato, livello e scarico olio. L'utente può immettere olio minerale mantenendo i tappi esistenti. Se immetterà olio sintetico, dovrà sostituire i tappi esistenti con altri tipo chiuso. Il riduttore 050 è fornito lubrificato a vita con olio sintetico. Tab.1 per oli e quantità consigliati. Tab.2 carichi radiali e assiali applicabili al riduttore. Per la documentazione completa consulta il nostro sito.

D Das Getriebe der Baugröße 115 wird ohne Schmiermittel geliefert. Es ist jedoch mit Einfüllschraube, Überdruckventil und Ablassschraube ausgerüstet. Das benötigte mineralische Öl kann über die Einfüllschraube eingefüllt werden. Sollte synthetisches Öl bevorzugt werden, so ist sind das eingebaute Überdruckventil durch eine geschlossenen Schraube zu ersetzen. Das Getriebe der Baugröße 050 ist lebensdauer geschmiert. In Tabelle 1 ist die Schmiermenge und das empfohlene Schmiermittel angegeben. In Tabelle 2 sind die zulässigen Radial - und Axialbelastungen des Getriebes aufgeführt. Die komplette Dokumentation, Wartungs - und Inbetriebnahmeanleitungen finden Sie unter.

E El reductor tamaño 115 se suministra sin lubricante, provisto de tapones de respiración, nivel y descarga de aceite. El usuario puede utilizar aceite mineral, manteniendo los tapones existentes. Si prefiera utilizar aceite sintético deberá sustituir los tapones existentes por tapones ciegos. El reductor 050 se suministra lubricado de por vida con aceite sintético. Ver tabla 1, para cantidades y aceites recomendados. En la tabla 2, se encuentran las cargas radiales y axiales admitidas por el reductor. Para documentación completa, consultar nuestra Web.

RADIAL AND AXIAL LOADS

Output shaft

Albero di uscita

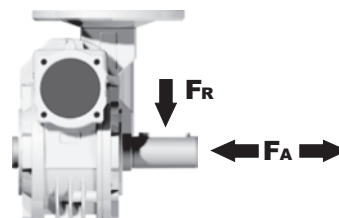

n_2 [min ⁻¹]	FA [N]	FR [N]
25	1200	6000
15	1400	7000

Input shaft

albero in entrata

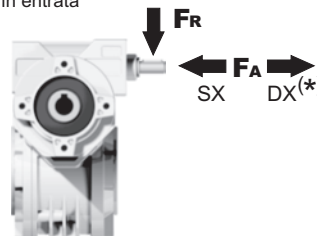

n_1 [min ⁻¹]	FA [N]	FR [N]
1400	76	380

*Strong axial loads in the DX direction are not allowed.
Non sono consentiti forti carichi assiali con direzione DX

tab. 2

SELECT THIS TYPE AND THIS SPECIFIC SIZE ON THE WEB PAGES TO GET COMPLETE TECHNICAL DATA.
Selezionare tipo e gandezza specifica nel sito web per la documentazione completa.

3D dimensions on request

P115FB... Basic wormbox
Riduttore base

Wormbox weight
peso riduttore **38.00 kg**

M. flanges	Kit code	øF	A
63B5	K050.4.041	138	76.5
71B5	K050.4.042	160	74.5
80B5	K050.4.043	200	76.5
56B14	KC40.4.049	80	76
63B14	K050.4.047	90	78.5
71B14	K050.4.045	105	76
80B14	K050.4.046	120	76.5

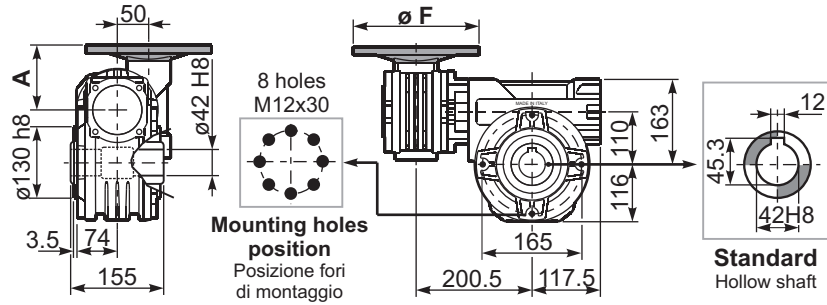

P115PA... Feet
Piedini

P115PB... Feet
Piedini

P115PV... Feet
Piedini

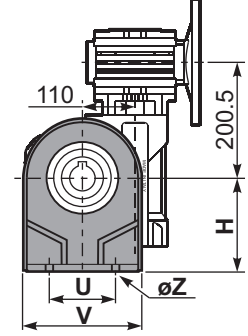
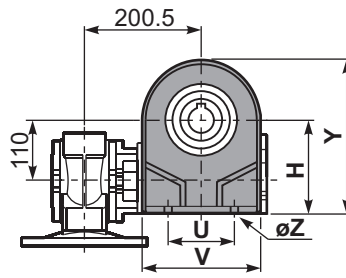
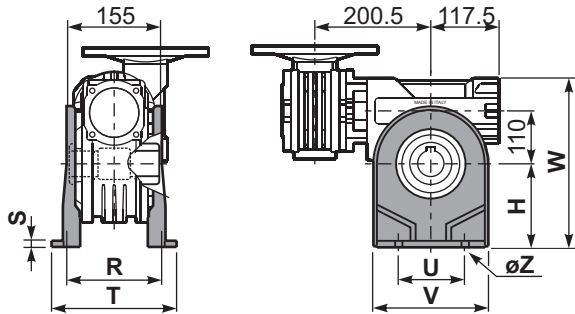

	H	R	S	T	U	V	Y	W	øZ	kit code
type B	170	180	22	224	200	240	286	333	ø13	K110.9.022
type S	172	160	18	190	200	240	288	335	ø14	KS110.9.023

P115FC... Output flange
Flangia uscita

P115BR... Reaction arm
Braccio di reazione

kit cod. K110.9.027

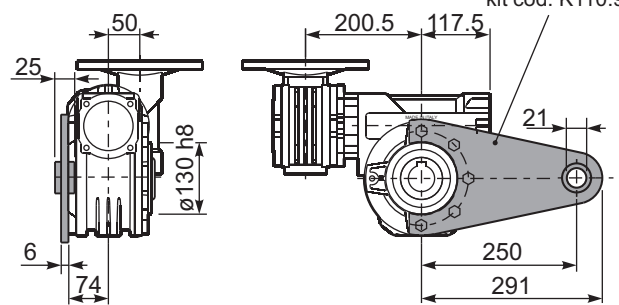
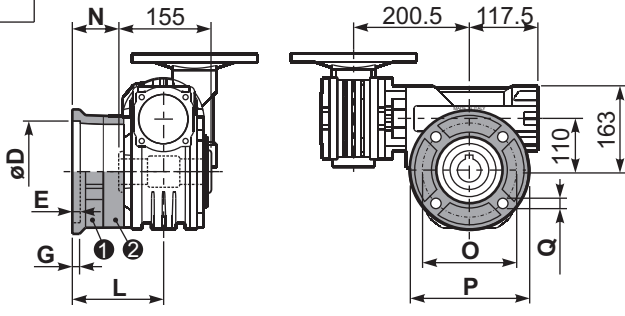

type B	øD	E	G	L	N	O	P	Q	kit code
FC	170 ^{+0.083} / _{+0.043}	11	16.5	131.5	54	230	270	13	① K110.9.010 ② -
FL	170 ^{+0.083} / _{+0.043}	11	16.5	179.5	102	230	270	13	① K110.9.011 ② -
type S	øD	E	G	L	N	O	P	Q	kit code
F1	180 ^{+0.040} / ₀	5	18	150	72.5	215	250	15	① KS110.9.014 ② -
F2	170 ^{+0.083} / _{+0.043}	9.5	15	178	100.5	230	270	13	① KS110.9.012 ② -
F3	180 ^{+0.040} / ₀	5	18	130	52.5	215	250	15	① KS110.9.013 ② -

P115....S... Single Shaft
Albero lento semplice

P115....D... Double Shaft
Albero lento bisp.

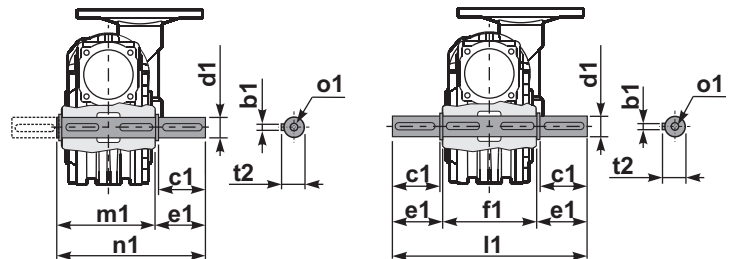

① kit cod. K110.5.028 type B

② kit cod. K110.5.029 type B

R115FB... Input shaft
Albero in entrata

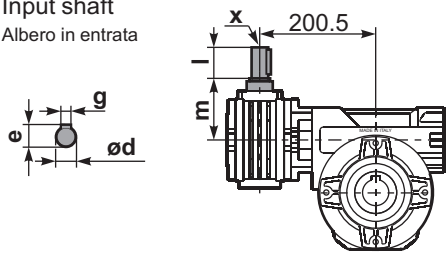

	ød	e	g	l	m	x	kit code
type B	16 h6	18	5	30	74.5	M6x16	① K050.5.006 PAM71 ② K050.5.007 PAM80
type S	14 h6	16	5	30	74.5	M5x10	① KS050.5.008 PAM71 ② KS050.5.009 PAM80

	b1	c1	d1	e1	f1	l1	m1	n1	t2	o1
type B	12	75	42 ^{-0.005} / _{-0.020}	96.5	155	348	163.5	260	45	M12x32
type S	-	-	-	-	-	-	-	-	-	-

Aluminum IEC motors

Aluminum motor IP55 class F

Motori solo in alluminio IP55 classe F

B5

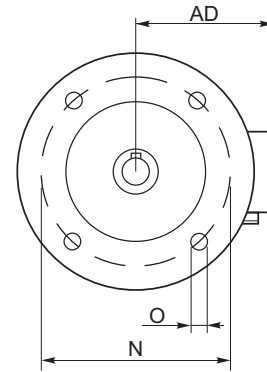
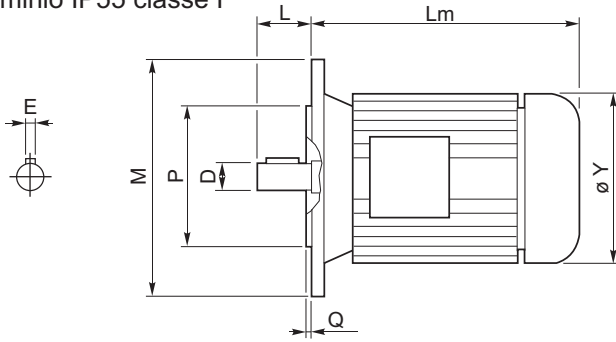

B14

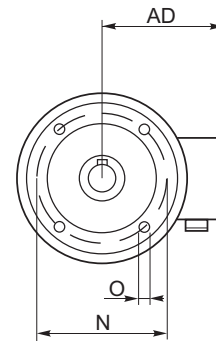
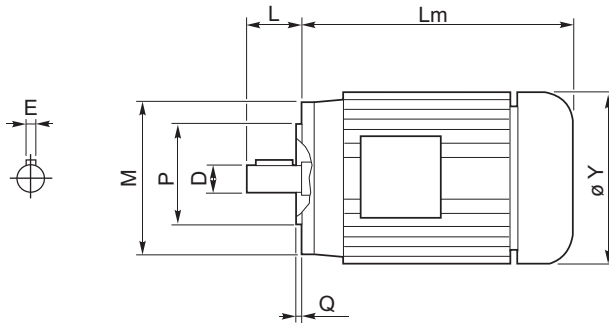

Outside dimensions may be different according to manufacturers.

Le dimensioni esterne sono indicative, possono variare tra i vari costruttori.

	2 poli / poles			4 poli / poles			6 poli / poles			B5-B14						B5					B14					Kg
	kW	Nm	A (400V)	kW	Nm	A (400V)	kW	Nm	A (400V)	D	E	L	Lm	Y	AD	P	N	M	O	Q	P	N	M	O	Q	
56 A	0.09	0.32	0.38	0.06	0.44	0.27	—	—	—	9	3	20	179	108	96	80	100	120	9	2.5	50	65	80	M5	2.5	2.7
56 B	0.12	0.42	0.46	0.09	0.67	0.37	—	—	—																	2.9
63 A	0.18	0.63	0.60	0.12	0.84	0.50	0.09	0.99	0.57	11	4	23	185	120	99	95	115	140	9.5	3	60	75	90	M5	2.5	3.8
63 B	0.25	0.87	0.76	0.18	1.30	0.69	0.12	1.32	0.74																	4.2
71 A	0.37	1.30	1.00	0.25	1.70	0.91	0.18	1.90	0.80	14	5	30	-	130	104	110	130	160	9.5	3.5	70	85	105	M6	2.5	5.9
71 B	0.55	1.90	1.54	0.37	2.52	1.14	0.25	2.72	1.10				225	141	107											6.5
80 A	0.75	2.60	1.85	0.55	3.77	1.51	0.37	3.84	1.18	19	6	40	256	159	127	130	165	200	11.5	3.5	80	100	120	M6	3	8.5
80 B	1.1	3.90	2.64	0.75	5.11	2.57	0.55	5.84	1.80																	10
90 S	1.5	5.00	3.31	1.1	7.45	2.78	0.75	7.92	2.32	24	8	50	-	170	135	130	165	200	11.5	3.5	95	115	140	M8	3	12.5
90 L	2.2	7.50	4.46	1.5	10.2	3.61	1.1	11.6	3.45				280													15
100 LA	3.0	10.0	6.28	2.2	14.8	5.07	1.5	15.4	3.88	28	8	60	-	190	148	180	215	250	13	4	110	130	160	M8	3.5	20
100 LB	—	—	—	3.0	20.1	6.66	—	—	—																	22
112 M	4.0	13.4	8.10	4.0	26.7	8.55	2.2	22.6	5.30				321	210	164											35
132 S	5.5	18.3	11.2	5.5	36.5	11.4	3.0	30.2	7.20	38	10	80	375	244	180	230	265	300	14	4	130	165	200	M10	4	41
	7.5	24.9	15.3																							51
132 M	—	—	—	7.5	49.4	15.0	4.0	40.0	9.13				420													51

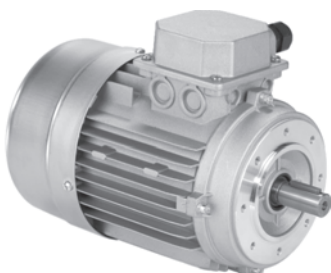

Metric electric motors are in aluminum. On request they can be supplied with different Level of protection and painted with 2 or 3 level of anticorrosive paint.

I motori metrici sono in alluminio, su richiesta possono essere forniti con differenti livelli di protezione e verniciati con vernice anticorrosiva.

ELECTRIC MOTORS / MOTORI ELETTRICI ELEKTROMOTOREN / MOTORES ELÉCTRICOS

Protection

Standard IP55
Please specify on purchase orders if you need a higher IP protection class.

Grado di protezione

IP55 Standard
Specificare in sede di ordinazione per IP superiore.

Schutzart

IP55 Standard.
Höheren IP Grad bitte im Auftrag angeben.

Grado de protección

IP55 standard.
Especificar en el pedido cuando necesiten protección IP superior.

Insulation

Standard Cl.F
To be specified upon placing the order if different insulation is required.

Isolamento

Cl.F Standard
Specificare in sede di ordinazione classe di isolamento diversa

Isolierung

Cl.F Standard.
Davon abweichende Isolierungsklasse im Auftrag angeben

Aislamiento

Cl.F standard.
Especificar al efectuar el pedido la clase diferente de aislamiento.

Insulation / Isolamento Isolierung / Aislamiento		E	B	F	H
Max. temp.	C°	120°	130°	155°	175°
	F*	248°	266°	311°	347°

Connections

Threephase asynchronous single polarity
Asincrono trifase singola polarità
Asynchronmotor 3-ph eine Drehzahl
Asincrono trifasico de una velocidad

Collegamenti

Threephase asynchronous double polarity
Asincrono trifase doppia polarità
Asynchronmotor 3-ph doppelte Drehzahl
Asincrono trifasico de dos velocidades

Verbindungselemente

Conexiones

Single phase asynchronous
Asincrono monofase
Einphasen-Asynchronmotor
Asincrono monofasico

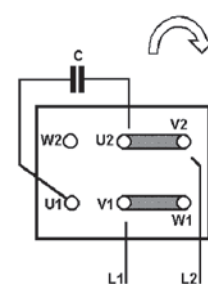
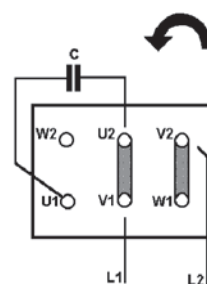
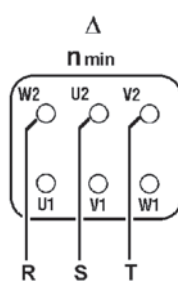
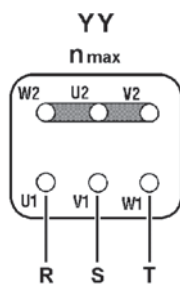
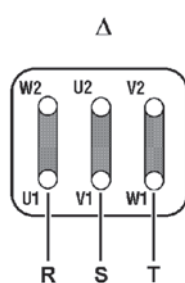
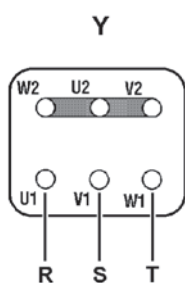

Please Read Carefully

The following WARNING and CAUTION information is supplied to you for your protection and to provide you with many years of trouble free and safe operation of your product.

Read ALL instructions prior to operating reducer. Injury to personnel or reducer failure may be caused by improper installation, maintenance or operation.

WARNING:

- Written authorization required to operate or use reducers in man lift or people moving devices.
- Check to make sure that certain applications do not exceed the allowable load capacities published in the current catalog.
- Buyer shall be solely responsible for determining the adequacy of the product for any and all uses to which Buyer shall apply the product. The application by Buyer shall not be subject to any implied warranty of fitness for a particular purpose.
- For safety, Buyer or User should provide protective guards over all shaft extensions and any moving apparatus mounted thereon. The User is responsible for checking all applicable safety codes in his area and providing suitable guards. Failure to do so may result in bodily injury and/or damage to equipment.
- Hot oil and reducers can cause severe burns. Use extreme care when removing lubrication plugs and vents.
- Make certain that the power supply is disconnected before attempting to service or remove any components. Lock out the power supply and tag it to prevent unexpected application power.
- Reducers are not to be considered fail safe or self-locking devices. If these features are required, a properly sized, independent holding device should be utilized. Reducers should not be used as a brake.
- Any brakes that are used in conjunction with a reducer must be sized or positioned in such a way so as to not subject the reducer to loads beyond the catalog rating.
- Lifting supports including eyebolts are to be used for vertically lifting the gearbox only and not other associated attachments or motors.
- Use of an oil with an EP additive on units with backstops may prevent proper operation of the backstop. Injury to personnel, damage to the reducer or other equipment may result.
- Overhung loads subject shaft bearings and shafts to stress which may cause premature bearing failure and or shaft breakage from bending fatigue, if not sized properly.

Our company will not be responsible for any direct or indirect damages, caused by a wrong use of the products or for not observing the catalogue/web indication

Leggere attentamente

Le seguenti raccomandazioni sono fondamentali per la vostra protezione e per garantirvi molti anni di sicuro funzionamento del vostro prodotto senza alcun problema.

Leggere attentamente tutte le istruzioni prima di azionare il riduttore. L'inappropriata installazione, manutenzione o funzionamento del riduttore può causare incidenti al personale addetto e danni al riduttore stesso.

ATTENZIONE!

- E' richiesta autorizzazione scritta per azionare riduttori in ascensori o dispositivi per il movimento delle persone.
- Controllare che alcune applicazioni non eccedano la massima capacità di carico ammessa pubblicata in questo catalogo.
- L'acquirente è l'unico responsabile per la determinazione dell'adeguatezza del prodotto per qualcuna o tutte le utilizzazioni che l'acquirente stesso farà del riduttore. L'applicazione dell'acquirente non potrà essere soggetta ad alcuna implicita garanzia di montaggio per uno scopo particolare.
- Per ragioni di sicurezza l'acquirente dovrà provvedere a porre protezioni adeguate su tutta la lunghezza dell'albero a tutti gli organi in movimento. L'utilizzatore è responsabile del controllo di tutti i codici di sicurezza e la predisposizione di protezioni adeguate. In assenza di tali precauzioni si possono verificare incidenti alle persone e danni agli apparati.
- Olio e riduttori bollenti possono causare gravi ustioni. Usare estrema cautela nella rimozione dei tappi e delle ventole.
- Assicurarsi che la corrente di alimentazione sia scollegata prima di riparare o rimuovere alcun componente. Chiudere l'alimentazione e contrassegnare tale operazione per evitare accensioni accidentali.
- I riduttori non devono essere considerati esenti da guasti o a bloccaggio automatico. Se sono indispensabili queste caratteristiche, deve essere utilizzato un dispositivo indipendente della dimensione adatta. I riduttori non devono essere utilizzati come freni.
- Qualsiasi freno sia utilizzato insieme al riduttore deve essere della giusta grandezza e posizionato in modo da non causare carichi eccessivi non previsti dai dati forniti nel catalogo.
- I dispositivi di sollevamento come le golfare devono essere usati solo per sollevare verticalmente il riduttore e non altri dispositivi associati o motori.
- L'utilizzo di un olio con un additivo EP su gruppi provvisti di dispositivo di arresto possono inficiare l'uso corretto del freno e provocare danni alle persone, alle cose ed al riduttore stesso nonché ad altri apparecchi.
- I Carichi sospesi assoggettano i cuscinetti della vite e la vite stessa a sollecitazioni che possono causare, se non adeguatamente dimensionati, l'usura prematura dei cuscinetti e/o la rottura della vite a causa della resistenza alla flessione.

La nostra ditta non si ritiene responsabile per eventuali danni diretti o indiretti derivanti da un uso improprio dei prodotti e dalla mancata osservanza delle indicazioni riportate a catalogo o web..

HYDRO-MEC *A modern production of Modular products*



One step gearboxes
Riduttori ad uno stadio



Square worm gearboxes
Rid. a vite senza fine quadro



Stainless steel worm gearboxes
Rid. a vite senza fine Inox



Coaxial gearboxes
Riduttori coassiali



Shaft mounted gearboxes
Rid. ad assi paralleli

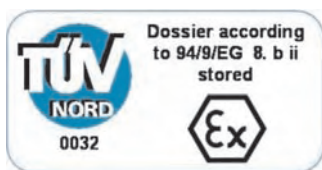
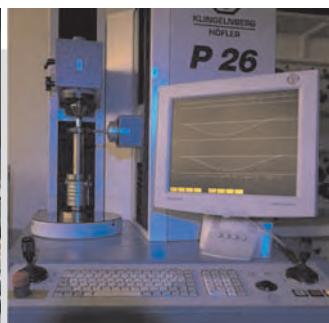

Dossier according
to 94/9/EG 8. b ii
stored



Distributed From:

HYDRO-MEC

Via della tecnica, 19
36050 SOVIZZO (VI) ITALY

Tel. : +39 0444 551911
Fax : +39 0444 536139

hydromec@hydromec.com



* CT- VFM- BS- HMD10*

